

## **APPENDIX J**

---

### Turning Movement Volumes

# Traffic Data Service

Campbell, CA  
(408) 377-2988  
tdsbay@cs.com

File Name : 25AM FINAL  
Site Code : 00000025  
Start Date : 11/16/2010  
Page No : 1

### Groups Printed- Vehicles

Start Time	HAVEN AVE Southbound					MARSH RD Westbound					BAYFRONT EXPY Northbound					MARSH RD Eastbound					Int. Total
	Right	Thru	Left	Peds	App. Total	Right	Thru	Left	Peds	App. Total	Right	Thru	Left	Peds	App. Total	Right	Thru	Left	Peds	App. Total	
07:00 AM	25	10	1	0	36	1	1	1	0	3	3	30	404	0	437	127	10	33	0	170	646
07:15 AM	34	8	1	0	43	2	4	1	0	7	2	36	468	0	506	175	10	40	0	225	781
07:30 AM	48	15	1	0	64	0	7	0	0	7	9	30	621	0	660	219	3	37	0	259	990
07:45 AM	47	17	1	0	65	4	3	2	0	9	4	53	635	0	692	224	5	52	0	281	1047
<b>Total</b>	<b>154</b>	<b>50</b>	<b>4</b>	<b>0</b>	<b>208</b>	<b>7</b>	<b>15</b>	<b>4</b>	<b>0</b>	<b>26</b>	<b>18</b>	<b>149</b>	<b>2128</b>	<b>0</b>	<b>2295</b>	<b>745</b>	<b>28</b>	<b>162</b>	<b>0</b>	<b>935</b>	<b>3464</b>
08:00 AM	36	14	1	0	51	1	3	2	0	6	6	65	506	0	577	274	4	59	0	337	971
08:15 AM	17	12	4	0	33	0	6	3	0	9	4	41	535	0	580	280	8	34	0	322	944
08:30 AM	32	35	1	0	68	0	7	4	0	11	3	41	487	0	531	261	17	47	0	325	935
08:45 AM	35	29	1	0	65	3	5	2	0	10	2	39	496	0	537	231	16	55	0	302	914
<b>Total</b>	<b>120</b>	<b>90</b>	<b>7</b>	<b>0</b>	<b>217</b>	<b>4</b>	<b>21</b>	<b>11</b>	<b>0</b>	<b>36</b>	<b>15</b>	<b>186</b>	<b>2024</b>	<b>0</b>	<b>2225</b>	<b>1046</b>	<b>45</b>	<b>195</b>	<b>0</b>	<b>1286</b>	<b>3764</b>
<b>Grand Total</b>	<b>274</b>	<b>140</b>	<b>11</b>	<b>0</b>	<b>425</b>	<b>11</b>	<b>36</b>	<b>15</b>	<b>0</b>	<b>62</b>	<b>33</b>	<b>335</b>	<b>4152</b>	<b>0</b>	<b>4520</b>	<b>1791</b>	<b>73</b>	<b>357</b>	<b>0</b>	<b>2221</b>	<b>7228</b>
<b>Apprch %</b>	<b>64.5</b>	<b>32.9</b>	<b>2.6</b>	<b>0</b>		<b>17.7</b>	<b>58.1</b>	<b>24.2</b>	<b>0</b>		<b>0.7</b>	<b>7.4</b>	<b>91.9</b>	<b>0</b>		<b>80.6</b>	<b>3.3</b>	<b>16.1</b>	<b>0</b>		
<b>Total %</b>	<b>3.8</b>	<b>1.9</b>	<b>0.2</b>	<b>0</b>	<b>5.9</b>	<b>0.2</b>	<b>0.5</b>	<b>0.2</b>	<b>0</b>	<b>0.9</b>	<b>0.5</b>	<b>4.6</b>	<b>57.4</b>	<b>0</b>	<b>62.5</b>	<b>24.8</b>	<b>1</b>	<b>4.9</b>	<b>0</b>	<b>30.7</b>	

Start Time	HAVEN AVE Southbound					MARSH RD Westbound					BAYFRONT EXPY Northbound					MARSH RD Eastbound					Int. Total
	Right	Thru	Left	Peds	App. Total	Right	Thru	Left	Peds	App. Total	Right	Thru	Left	Peds	App. Total	Right	Thru	Left	Peds	App. Total	
Peak Hour Analysis From 07:00 AM to 08:45 AM - Peak 1 of 1																					
Peak Hour for Entire Intersection Begins at 07:30 AM																					
07:30 AM	48	15	1	0	64	0	7	0	0	7	9	30	621	0	660	219	3	37	0	259	990
07:45 AM	47	17	1	0	65	4	3	2	0	9	4	53	635	0	692	224	5	52	0	281	1047
08:00 AM	36	14	1	0	51	1	3	2	0	6	6	65	506	0	577	274	4	59	0	337	971
08:15 AM	17	12	4	0	33	0	6	3	0	9	4	41	535	0	580	280	8	34	0	322	944
<b>Total Volume</b>	<b>148</b>	<b>58</b>	<b>7</b>	<b>0</b>	<b>213</b>	<b>5</b>	<b>19</b>	<b>7</b>	<b>0</b>	<b>31</b>	<b>23</b>	<b>189</b>	<b>2297</b>	<b>0</b>	<b>2509</b>	<b>997</b>	<b>20</b>	<b>182</b>	<b>0</b>	<b>1199</b>	<b>3952</b>
<b>% App. Total</b>																					
<b>PHF</b>	<b>.771</b>	<b>.853</b>	<b>.438</b>	<b>.000</b>	<b>.819</b>	<b>.313</b>	<b>.679</b>	<b>.583</b>	<b>.000</b>	<b>.861</b>	<b>.639</b>	<b>.727</b>	<b>.904</b>	<b>.000</b>	<b>.906</b>	<b>.890</b>	<b>.625</b>	<b>.771</b>	<b>.000</b>	<b>.889</b>	<b>.944</b>

# Traffic Data Service

Campbell, CA  
 (408) 377-2988  
 tdsbay@cs.com

File Name : 25AM FINAL  
 Site Code : 00000025  
 Start Date : 11/16/2010  
 Page No : 2

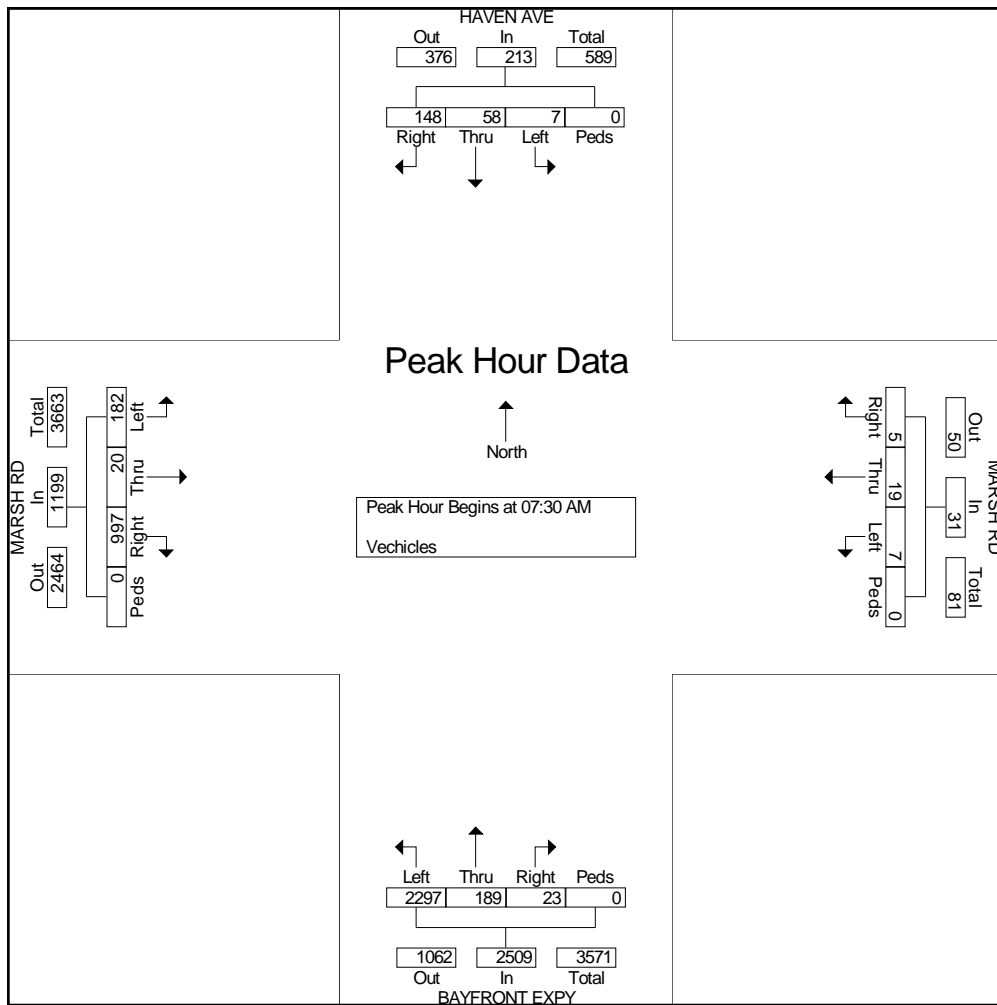

# All Traffic Data

(916) 771-8700

CITY OF MENLOW PARK

File Name : 11-7184-003 MARSH-BAYFRONT EXPY

Site Code : 00000000

Start Date : 5/3/2011

Page No : 1

## Groups Printed- Unshifted

Start Time	MARSH RD. Southbound				BAYFRONT EXPY Westbound				MARSH RD. Northbound				HAVEN AVE. Eastbound				Int. Total
	Left	Thru	Right	App. Total	Left	Thru	Right	App. Total	Left	Thru	Right	App. Total	Left	Thru	Right	App. Total	
08:30	4	7	1	12	576	37	2	615	39	17	220	276	2	36	33	71	974
08:45	4	10	0	14	512	50	4	566	35	11	228	274	2	23	31	56	910
Total	8	17	1	26	1088	87	6	1181	74	28	448	550	4	59	64	127	1884
09:00	5	16	3	24	451	29	7	487	42	11	233	286	0	20	26	46	843
09:15	4	11	1	16	449	27	1	477	40	14	204	258	1	23	60	84	835
09:30	3	11	0	14	410	30	3	443	48	9	175	232	2	13	41	56	745
09:45	2	6	2	10	349	11	5	365	36	12	166	214	1	13	30	44	633
Total	14	44	6	64	1659	97	16	1772	166	46	778	990	4	69	157	230	3056
10:00	3	28	2	33	224	19	3	246	44	13	146	203	1	14	31	46	528
10:15	1	12	1	14	256	12	2	270	28	2	144	174	0	17	31	48	506
Grand Total	26	101	10	137	3227	215	27	3469	312	89	1516	1917	9	159	283	451	5974
Apprch %	19	73.7	7.3		93	6.2	0.8		16.3	4.6	79.1		2	35.3	62.7		
Total %	0.4	1.7	0.2	2.3	54	3.6	0.5	58.1	5.2	1.5	25.4	32.1	0.2	2.7	4.7	7.5	

Start Time	MARSH RD. Southbound				BAYFRONT EXPY Westbound				MARSH RD. Northbound				HAVEN AVE. Eastbound				Int. Total
	Left	Thru	Right	App. Total	Left	Thru	Right	App. Total	Left	Thru	Right	App. Total	Left	Thru	Right	App. Total	
Peak Hour Analysis From 08:30 to 10:15 - Peak 1 of 1																	
Peak Hour for Entire Intersection Begins at 08:30																	
08:30	4	7	1	12	<b>576</b>	37	2	<b>615</b>	39	<b>17</b>	220	276	<b>2</b>	<b>36</b>	33	71	<b>974</b>
08:45	4	10	0	14	512	<b>50</b>	4	566	35	11	228	274	2	23	31	56	910
09:00	<b>5</b>	<b>16</b>	<b>3</b>	<b>24</b>	451	29	<b>7</b>	487	<b>42</b>	11	<b>233</b>	<b>286</b>	0	20	26	46	843
09:15	4	11	1	16	449	27	1	477	40	14	204	258	1	23	<b>60</b>	<b>84</b>	835
Total Volume	17	44	5	66	1988	143	14	2145	156	53	885	1094	5	102	150	257	3562
% App. Total	25.8	66.7	7.6		92.7	6.7	0.7		14.3	4.8	80.9		1.9	39.7	58.4		
PHF	.850	.688	.417	.688	.863	.715	.500	.872	.929	.779	.950	.956	.625	.708	.625	.765	.914

# All Traffic Data

(916) 771-8700

CITY OF MENLOW PARK

File Name : 11-7184-003 MARSH-BAYFRONT EXPY

Site Code : 00000000

Start Date : 5/3/2011

Page No : 2

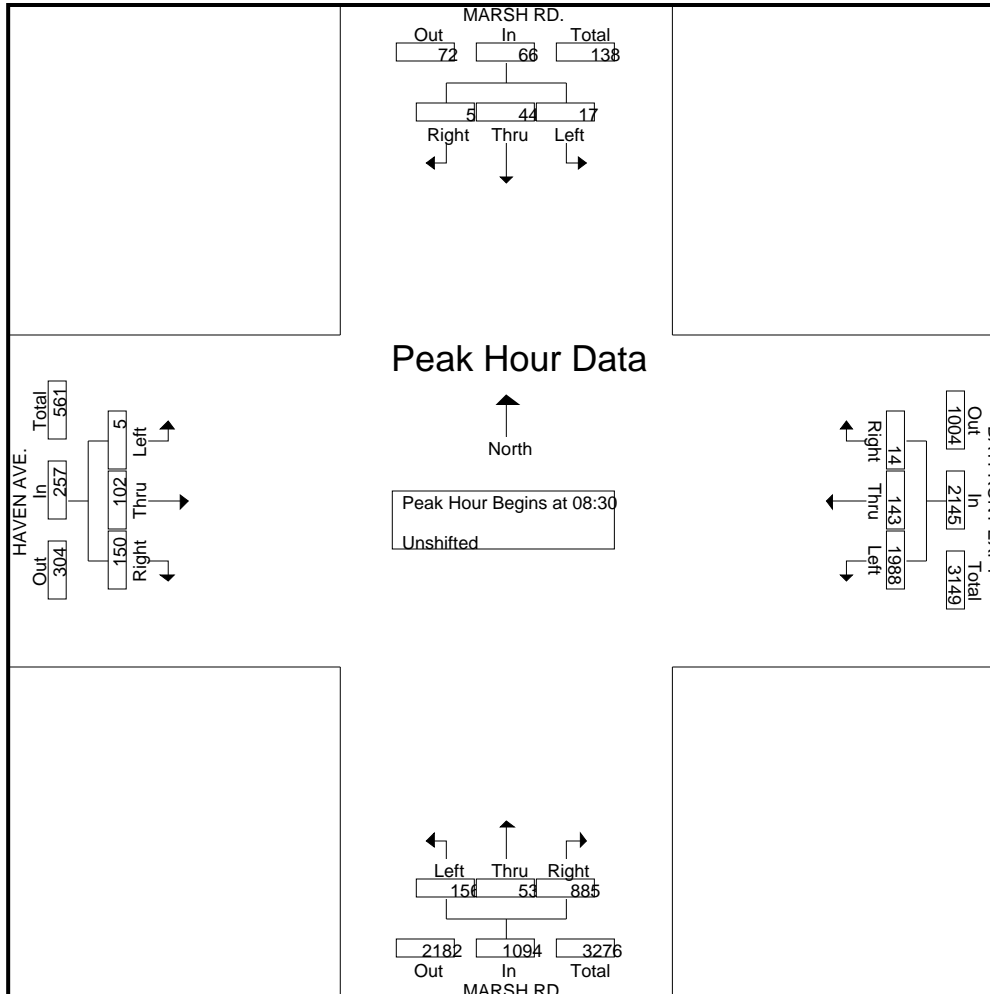

# Traffic Data Service

Campbell, CA  
(408) 377-2988  
tdsbay@cs.com

File Name : 25PM FINAL  
Site Code : 00000025  
Start Date : 11/16/2010  
Page No : 1

## Groups Printed- Vehicles

Start Time	HAVEN AVE Southbound					MARSH RD Westbound					BAYFRONT EXPY Northbound					MARSH RD Eastbound					Int. Total
	Right	Thru	Left	Peds	App. Total	Right	Thru	Left	Peds	App. Total	Right	Thru	Left	Peds	App. Total	Right	Thru	Left	Peds	App. Total	
04:00 PM	61	48	0	0	109	2	2	4	0	8	3	11	236	0	250	376	10	18	0	404	771
04:15 PM	42	49	1	0	92	1	3	6	0	10	8	18	243	0	269	450	22	35	0	507	878
04:30 PM	41	38	1	0	80	1	12	1	0	14	7	23	275	0	305	454	15	36	0	505	904
04:45 PM	45	64	0	0	109	1	20	7	0	28	5	11	261	0	277	485	23	31	0	539	953
<b>Total</b>	<b>189</b>	<b>199</b>	<b>2</b>	<b>0</b>	<b>390</b>	<b>5</b>	<b>37</b>	<b>18</b>	<b>0</b>	<b>60</b>	<b>23</b>	<b>63</b>	<b>1015</b>	<b>0</b>	<b>1101</b>	<b>1765</b>	<b>70</b>	<b>120</b>	<b>0</b>	<b>1955</b>	<b>3506</b>
05:00 PM	55	86	0	0	141	3	21	4	0	28	2	14	313	0	329	490	13	53	0	556	1054
05:15 PM	43	96	0	0	139	4	14	14	0	32	0	11	299	0	310	495	4	31	0	530	1011
05:30 PM	43	100	0	0	143	3	18	6	0	27	0	13	311	0	324	482	0	24	0	506	1000
05:45 PM	15	51	0	0	66	0	7	1	0	8	0	8	234	0	242	461	0	36	0	497	813
<b>Total</b>	<b>156</b>	<b>333</b>	<b>0</b>	<b>0</b>	<b>489</b>	<b>10</b>	<b>60</b>	<b>25</b>	<b>0</b>	<b>95</b>	<b>2</b>	<b>46</b>	<b>1157</b>	<b>0</b>	<b>1205</b>	<b>1928</b>	<b>17</b>	<b>144</b>	<b>0</b>	<b>2089</b>	<b>3878</b>
Grand Total	345	532	2	0	879	15	97	43	0	155	25	109	2172	0	2306	3693	87	264	0	4044	7384
Apprch %	39.2	60.5	0.2	0		9.7	62.6	27.7	0		1.1	4.7	94.2	0		91.3	2.2	6.5	0		
Total %	4.7	7.2	0	0	11.9	0.2	1.3	0.6	0	2.1	0.3	1.5	29.4	0	31.2	50	1.2	3.6	0	54.8	

Start Time	HAVEN AVE Southbound					MARSH RD Westbound					BAYFRONT EXPY Northbound					MARSH RD Eastbound					Int. Total
	Right	Thru	Left	Peds	App. Total	Right	Thru	Left	Peds	App. Total	Right	Thru	Left	Peds	App. Total	Right	Thru	Left	Peds	App. Total	
Peak Hour Analysis From 04:00 PM to 05:45 PM - Peak 1 of 1																					
Peak Hour for Entire Intersection Begins at 04:45 PM																					
04:45 PM	45	64	0	0	109	1	20	7	0	28	5	11	261	0	277	485	23	31	0	539	953
05:00 PM	55	86	0	0	141	3	21	4	0	28	2	14	313	0	329	490	13	53	0	556	1054
05:15 PM	43	96	0	0	139	4	14	14	0	32	0	11	299	0	310	495	4	31	0	530	1011
05:30 PM	43	100	0	0	143	3	18	6	0	27	0	13	311	0	324	482	0	24	0	506	1000
Total Volume	186	346	0	0	532	11	73	31	0	115	7	49	1184	0	1240	1952	40	139	0	2131	4018
% App. Total																					
PHF	.845	.865	.000	.000	.930	.688	.869	.554	.000	.898	.350	.875	.946	.000	.942	.986	.435	.656	.000	.958	.953

# Traffic Data Service

Campbell, CA  
 (408) 377-2988  
 tdsbay@cs.com

File Name : 25PM FINAL  
 Site Code : 00000025  
 Start Date : 11/16/2010  
 Page No : 2

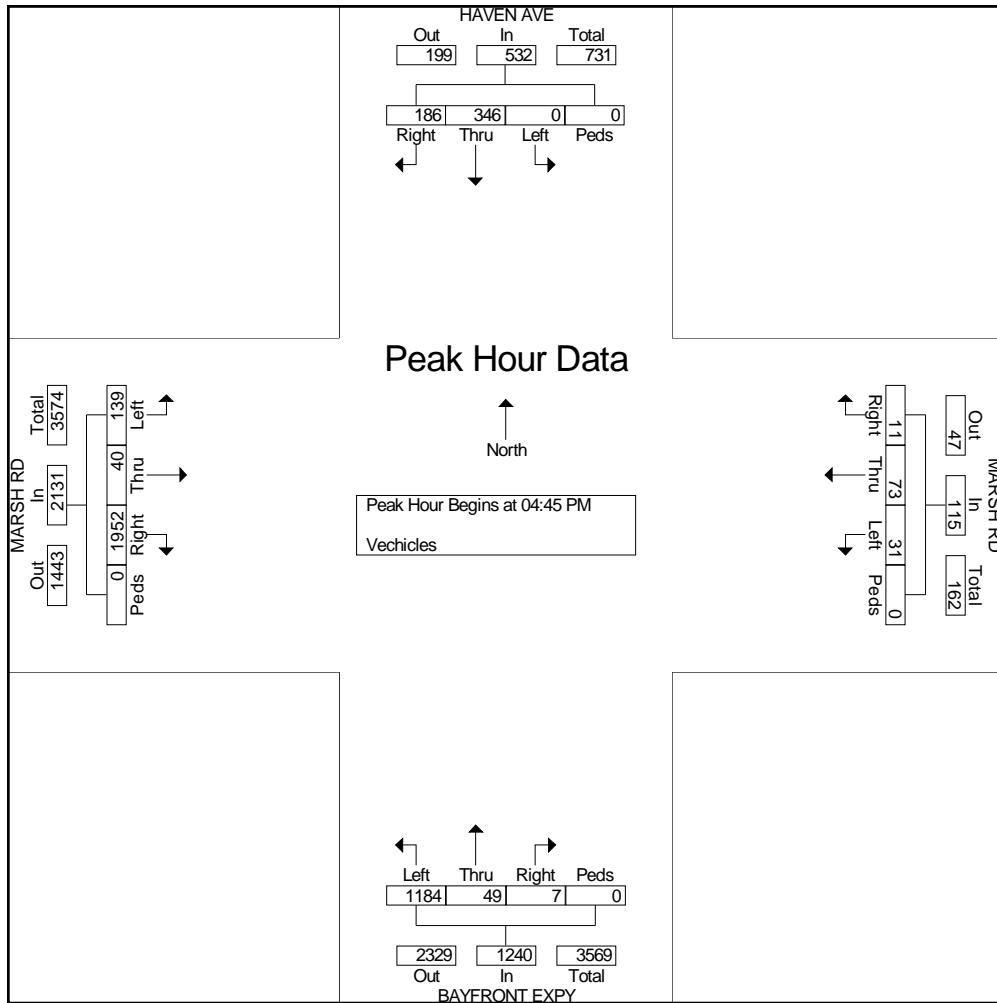

# Traffic Data Service

Campbell, CA  
(408) 377-2988  
tdsbay@cs.com

File Name : 26AM FINAL  
Site Code : 00000026  
Start Date : 11/17/2010  
Page No : 1

### Groups Printed- Vehicles

Start Time	Southbound					MARSH RD Westbound					US-101 NB RAMPS Northbound					MARSH RD Eastbound					Int. Total
	Right	Thru	Left	Peds	App. Total	Right	Thru	Left	Peds	App. Total	Right	Thru	Left	Peds	App. Total	Right	Thru	Left	Peds	App. Total	
07:00 AM	0	0	0	0	0	327	159	0	0	486	56	0	126	0	182	86	192	0	0	278	946
07:15 AM	0	0	0	0	0	418	168	0	0	586	72	0	186	0	258	124	259	0	0	383	1227
07:30 AM	0	0	0	0	0	454	234	0	0	688	69	0	201	0	270	121	273	0	0	394	1352
07:45 AM	0	0	0	0	0	445	211	0	0	656	63	0	212	0	275	125	305	0	0	430	1361
<b>Total</b>	<b>0</b>	<b>0</b>	<b>0</b>	<b>0</b>	<b>0</b>	<b>1644</b>	<b>772</b>	<b>0</b>	<b>0</b>	<b>2416</b>	<b>260</b>	<b>0</b>	<b>725</b>	<b>0</b>	<b>985</b>	<b>456</b>	<b>1029</b>	<b>0</b>	<b>0</b>	<b>1485</b>	<b>4886</b>
08:00 AM	0	0	0	0	0	382	208	0	0	590	85	0	219	0	304	136	301	0	0	437	1331
08:15 AM	0	0	0	0	0	382	146	0	0	528	95	0	139	0	234	135	300	0	0	435	1197
08:30 AM	0	0	0	0	0	408	133	0	0	541	97	0	141	0	238	154	348	0	0	502	1281
08:45 AM	0	0	0	0	0	439	174	0	0	613	108	0	156	0	264	192	263	0	0	455	1332
<b>Total</b>	<b>0</b>	<b>0</b>	<b>0</b>	<b>0</b>	<b>0</b>	<b>1611</b>	<b>661</b>	<b>0</b>	<b>0</b>	<b>2272</b>	<b>385</b>	<b>0</b>	<b>655</b>	<b>0</b>	<b>1040</b>	<b>617</b>	<b>1212</b>	<b>0</b>	<b>0</b>	<b>1829</b>	<b>5141</b>
Grand Total	0	0	0	0	0	3255	1433	0	0	4688	645	0	1380	0	2025	1073	2241	0	0	3314	10027
Apprch %	0	0	0	0	0	69.4	30.6	0	0	46.8	31.9	0	68.1	0	20.2	32.4	67.6	0	0	33.1	
Total %	0	0	0	0	0	32.5	14.3	0	0	46.8	6.4	0	13.8	0	20.2	10.7	22.3	0	0	33.1	

Start Time	Southbound					MARSH RD Westbound					US-101 NB RAMPS Northbound					MARSH RD Eastbound					Int. Total
	Right	Thru	Left	Peds	App. Total	Right	Thru	Left	Peds	App. Total	Right	Thru	Left	Peds	App. Total	Right	Thru	Left	Peds	App. Total	
Peak Hour Analysis From 07:00 AM to 08:45 AM - Peak 1 of 1																					
Peak Hour for Entire Intersection Begins at 07:15 AM																					
07:15 AM	0	0	0	0	0	418	168	0	0	586	72	0	186	0	258	124	259	0	0	383	1227
07:30 AM	0	0	0	0	0	454	234	0	0	688	69	0	201	0	270	121	273	0	0	394	1352
07:45 AM	0	0	0	0	0	445	211	0	0	656	63	0	212	0	275	125	305	0	0	430	1361
08:00 AM	0	0	0	0	0	382	208	0	0	590	85	0	219	0	304	136	301	0	0	437	1331
Total Volume	0	0	0	0	0	1699	821	0	0	2520	289	0	818	0	1107	506	1138	0	0	1644	5271
% App. Total																					
PHF	.000	.000	.000	.000	.000	.936	.877	.000	.000	.916	.850	.000	.934	.000	.910	.930	.933	.000	.000	.941	.968



# Traffic Data Service

Campbell, CA  
 (408) 377-2988  
 tdsbay@cs.com

File Name : 26AM FINAL  
 Site Code : 00000026  
 Start Date : 11/17/2010  
 Page No : 2

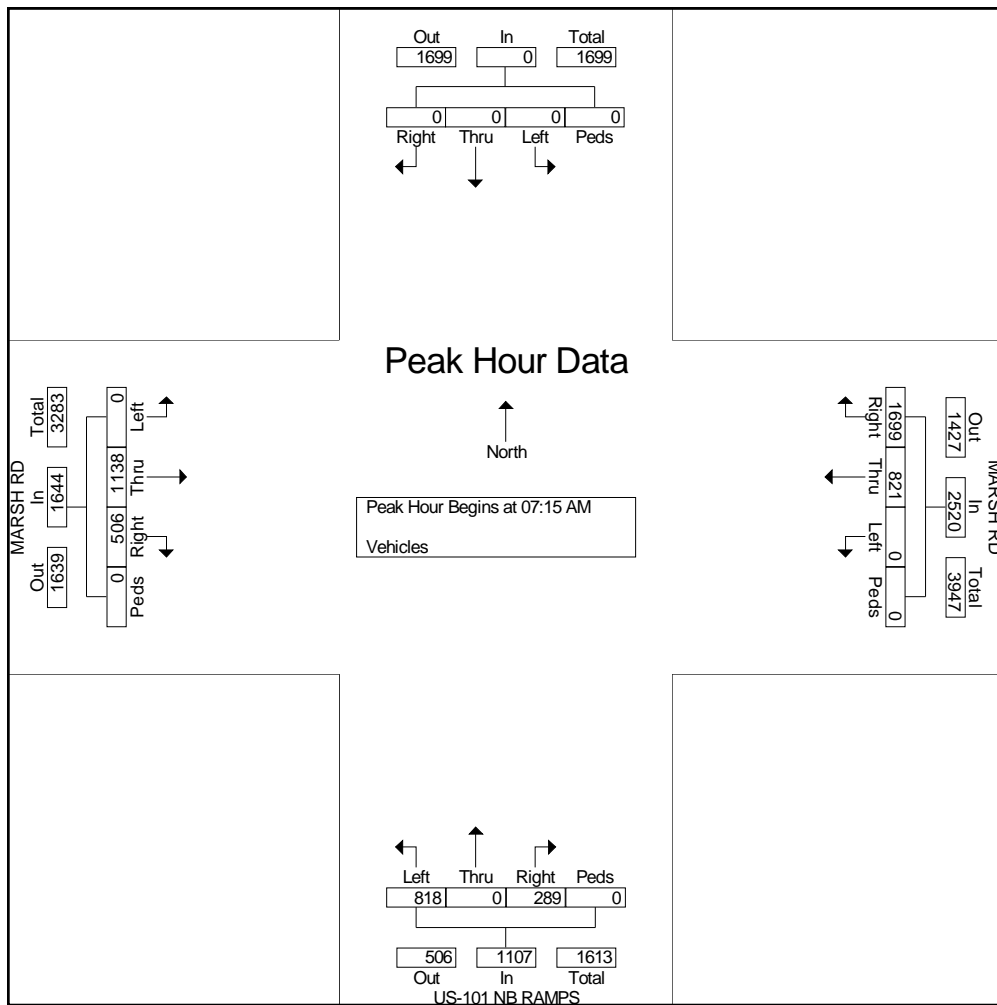

# Traffic Data Service

Campbell, CA  
(408) 377-2988  
tdsbay@cs.com

File Name : 26PM FINAL  
Site Code : 00000026  
Start Date : 11/17/2010  
Page No : 1

### Groups Printed- Vehicles

Start Time	Southbound					MARSH RD Westbound					US-101 NB RAMPS Northbound					MARSH RD Eastbound					Int. Total
	Right	Thru	Left	Peds	App. Total	Right	Thru	Left	Peds	App. Total	Right	Thru	Left	Peds	App. Total	Right	Thru	Left	Peds	App. Total	
04:00 PM	0	0	0	0	0	180	136	0	0	316	35	0	130	0	165	191	441	0	0	632	1113
04:15 PM	0	0	0	0	0	201	128	0	0	329	45	0	117	0	162	147	508	0	0	655	1146
04:30 PM	0	0	0	0	0	158	157	0	0	315	54	0	134	0	188	143	490	0	0	633	1136
04:45 PM	0	0	0	0	0	189	160	0	0	349	49	0	137	0	186	125	523	0	0	648	1183
<b>Total</b>	<b>0</b>	<b>0</b>	<b>0</b>	<b>0</b>	<b>0</b>	<b>728</b>	<b>581</b>	<b>0</b>	<b>0</b>	<b>1309</b>	<b>183</b>	<b>0</b>	<b>518</b>	<b>0</b>	<b>701</b>	<b>606</b>	<b>1962</b>	<b>0</b>	<b>0</b>	<b>2568</b>	<b>4578</b>
05:00 PM	0	0	0	0	0	207	190	0	0	397	63	0	108	0	171	136	548	0	0	684	1252
05:15 PM	0	0	0	0	0	184	162	0	0	346	58	0	123	0	181	125	496	0	0	621	1148
05:30 PM	0	0	0	0	0	211	170	0	0	381	43	0	125	0	168	121	496	0	0	617	1166
05:45 PM	0	0	0	0	0	177	138	0	0	315	43	0	157	0	200	115	469	0	0	584	1099
<b>Total</b>	<b>0</b>	<b>0</b>	<b>0</b>	<b>0</b>	<b>0</b>	<b>779</b>	<b>660</b>	<b>0</b>	<b>0</b>	<b>1439</b>	<b>207</b>	<b>0</b>	<b>513</b>	<b>0</b>	<b>720</b>	<b>497</b>	<b>2009</b>	<b>0</b>	<b>0</b>	<b>2506</b>	<b>4665</b>
Grand Total	0	0	0	0	0	1507	1241	0	0	2748	390	0	1031	0	1421	1103	3971	0	0	5074	9243
Apprch %	0	0	0	0	0	54.8	45.2	0	0	27.4	27.4	0	72.6	0	21.7	21.7	78.3	0	0	54.9	
Total %	0	0	0	0	0	16.3	13.4	0	0	29.7	4.2	0	11.2	0	15.4	11.9	43	0	0	54.9	

Start Time	Southbound					MARSH RD Westbound					US-101 NB RAMPS Northbound					MARSH RD Eastbound					Int. Total
	Right	Thru	Left	Peds	App. Total	Right	Thru	Left	Peds	App. Total	Right	Thru	Left	Peds	App. Total	Right	Thru	Left	Peds	App. Total	
Peak Hour Analysis From 04:00 PM to 05:45 PM - Peak 1 of 1																					
Peak Hour for Entire Intersection Begins at 04:45 PM																					
04:45 PM	0	0	0	0	0	189	160	0	0	349	49	0	137	0	186	125	523	0	0	648	1183
05:00 PM	0	0	0	0	0	207	190	0	0	397	63	0	108	0	171	136	548	0	0	684	1252
05:15 PM	0	0	0	0	0	184	162	0	0	346	58	0	123	0	181	125	496	0	0	621	1148
05:30 PM	0	0	0	0	0	211	170	0	0	381	43	0	125	0	168	121	496	0	0	617	1166
Total Volume	0	0	0	0	0	791	682	0	0	1473	213	0	493	0	706	507	2063	0	0	2570	4749
% App. Total																					
PHF	.000	.000	.000	.000	.000	.937	.897	.000	.000	.928	.845	.000	.900	.000	.949	.932	.941	.000	.000	.939	.948

# Traffic Data Service

Campbell, CA  
 (408) 377-2988  
 tdsbay@cs.com

File Name : 26PM FINAL  
 Site Code : 00000026  
 Start Date : 11/17/2010  
 Page No : 2

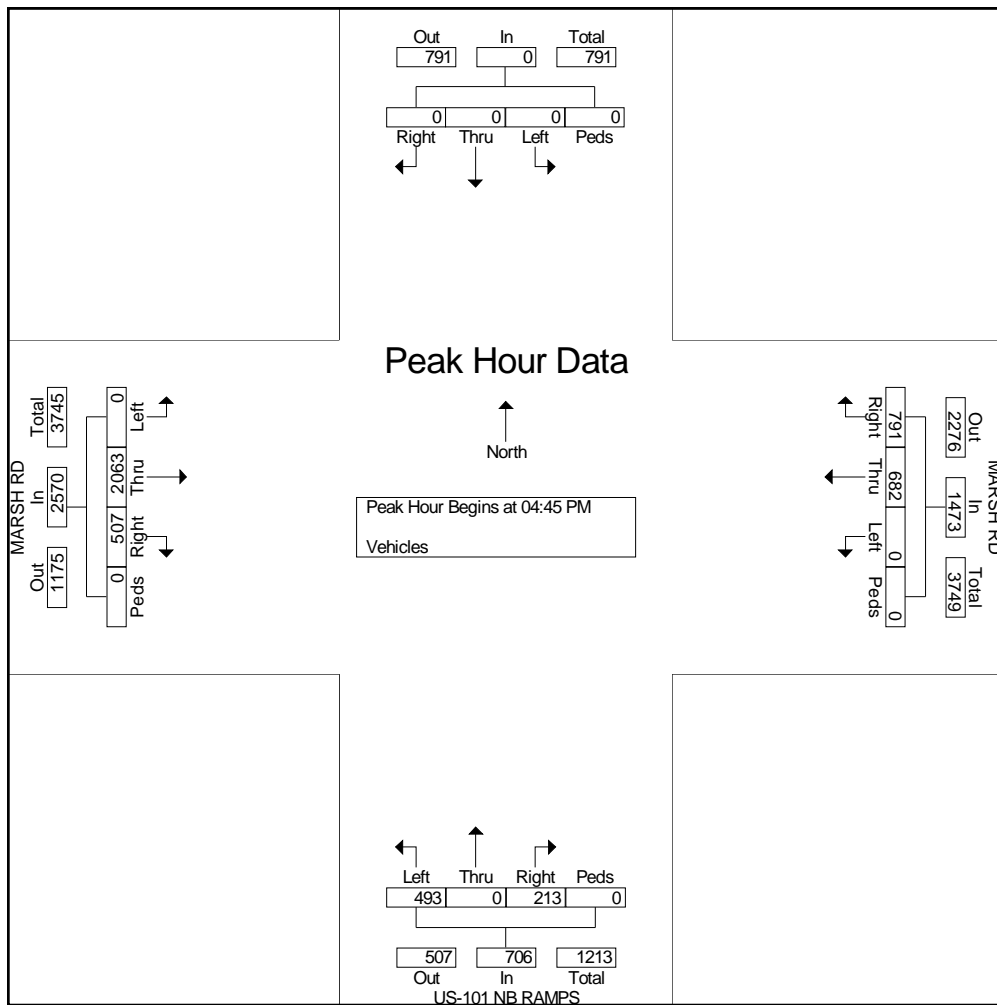

# Traffic Data Service

Campbell, CA  
(408) 377-2988  
tdsbay@cs.com

File Name : 27AM FINAL  
Site Code : 00000027  
Start Date : 11/17/2010  
Page No : 1

### Groups Printed- Vehicles

Start Time	US-101 SB RAMPS Southbound					MARSH RD Westbound					Northbound					MARSH RD Eastbound					Int. Total
	Right	Thru	Left	Peds	App. Total	Right	Thru	Left	Peds	App. Total	Right	Thru	Left	Peds	App. Total	Right	Thru	Left	Peds	App. Total	
07:00 AM	95	0	156	0	251	25	251	0	0	276	0	0	0	0	0	139	148	0	0	287	814
07:15 AM	114	0	193	0	307	26	323	0	0	349	0	0	0	0	0	136	195	0	0	331	987
07:30 AM	126	0	202	0	328	30	395	0	0	425	0	0	0	0	0	166	201	0	0	367	1120
07:45 AM	157	0	247	0	404	18	370	0	0	388	0	0	0	0	0	146	191	0	0	337	1129
<b>Total</b>	<b>492</b>	<b>0</b>	<b>798</b>	<b>0</b>	<b>1290</b>	<b>99</b>	<b>1339</b>	<b>0</b>	<b>0</b>	<b>1438</b>	<b>0</b>	<b>0</b>	<b>0</b>	<b>0</b>	<b>0</b>	<b>587</b>	<b>735</b>	<b>0</b>	<b>0</b>	<b>1322</b>	<b>4050</b>
08:00 AM	145	0	207	0	352	24	383	0	0	407	0	0	0	0	0	140	224	0	0	364	1123
08:15 AM	130	0	223	0	353	14	278	0	0	292	0	0	0	0	0	131	218	0	0	349	994
08:30 AM	119	0	254	0	373	19	249	0	0	268	0	0	0	0	0	111	209	0	0	320	961
08:45 AM	149	0	216	0	365	20	292	0	0	312	0	0	0	0	0	107	208	0	0	315	992
<b>Total</b>	<b>543</b>	<b>0</b>	<b>900</b>	<b>0</b>	<b>1443</b>	<b>77</b>	<b>1202</b>	<b>0</b>	<b>0</b>	<b>1279</b>	<b>0</b>	<b>0</b>	<b>0</b>	<b>0</b>	<b>0</b>	<b>489</b>	<b>859</b>	<b>0</b>	<b>0</b>	<b>1348</b>	<b>4070</b>
<b>Grand Total</b>	<b>1035</b>	<b>0</b>	<b>1698</b>	<b>0</b>	<b>2733</b>	<b>176</b>	<b>2541</b>	<b>0</b>	<b>0</b>	<b>2717</b>	<b>0</b>	<b>0</b>	<b>0</b>	<b>0</b>	<b>0</b>	<b>1076</b>	<b>1594</b>	<b>0</b>	<b>0</b>	<b>2670</b>	<b>8120</b>
<b>Apprch %</b>	<b>37.9</b>	<b>0</b>	<b>62.1</b>	<b>0</b>		<b>6.5</b>	<b>93.5</b>	<b>0</b>	<b>0</b>		<b>0</b>	<b>0</b>	<b>0</b>	<b>0</b>		<b>40.3</b>	<b>59.7</b>	<b>0</b>	<b>0</b>		
<b>Total %</b>	<b>12.7</b>	<b>0</b>	<b>20.9</b>	<b>0</b>	<b>33.7</b>	<b>2.2</b>	<b>31.3</b>	<b>0</b>	<b>0</b>	<b>33.5</b>	<b>0</b>	<b>0</b>	<b>0</b>	<b>0</b>		<b>13.3</b>	<b>19.6</b>	<b>0</b>	<b>0</b>	<b>32.9</b>	

Start Time	US-101 SB RAMPS Southbound					MARSH RD Westbound					Northbound					MARSH RD Eastbound					Int. Total
	Right	Thru	Left	Peds	App. Total	Right	Thru	Left	Peds	App. Total	Right	Thru	Left	Peds	App. Total	Right	Thru	Left	Peds	App. Total	
Peak Hour Analysis From 07:00 AM to 08:45 AM - Peak 1 of 1																					
Peak Hour for Entire Intersection Begins at 07:30 AM																					
07:30 AM	126	0	202	0	328	30	395	0	0	425	0	0	0	0	0	166	201	0	0	367	1120
07:45 AM	157	0	247	0	404	18	370	0	0	388	0	0	0	0	0	146	191	0	0	337	1129
08:00 AM	145	0	207	0	352	24	383	0	0	407	0	0	0	0	0	140	224	0	0	364	1123
08:15 AM	130	0	223	0	353	14	278	0	0	292	0	0	0	0	0	131	218	0	0	349	994
<b>Total Volume</b>	<b>558</b>	<b>0</b>	<b>879</b>	<b>0</b>	<b>1437</b>	<b>86</b>	<b>1426</b>	<b>0</b>	<b>0</b>	<b>1512</b>	<b>0</b>	<b>0</b>	<b>0</b>	<b>0</b>	<b>0</b>	<b>583</b>	<b>834</b>	<b>0</b>	<b>0</b>	<b>1417</b>	<b>4366</b>
<b>% App. Total</b>																					
<b>PHF</b>	<b>.889</b>	<b>.000</b>	<b>.890</b>	<b>.000</b>	<b>.889</b>	<b>.717</b>	<b>.903</b>	<b>.000</b>	<b>.000</b>	<b>.889</b>	<b>.000</b>	<b>.000</b>	<b>.000</b>	<b>.000</b>	<b>.000</b>	<b>.878</b>	<b>.931</b>	<b>.000</b>	<b>.000</b>	<b>.965</b>	<b>.967</b>

# Traffic Data Service

Campbell, CA  
 (408) 377-2988  
 tdsbay@cs.com

File Name : 27AM FINAL  
 Site Code : 00000027  
 Start Date : 11/17/2010  
 Page No : 2

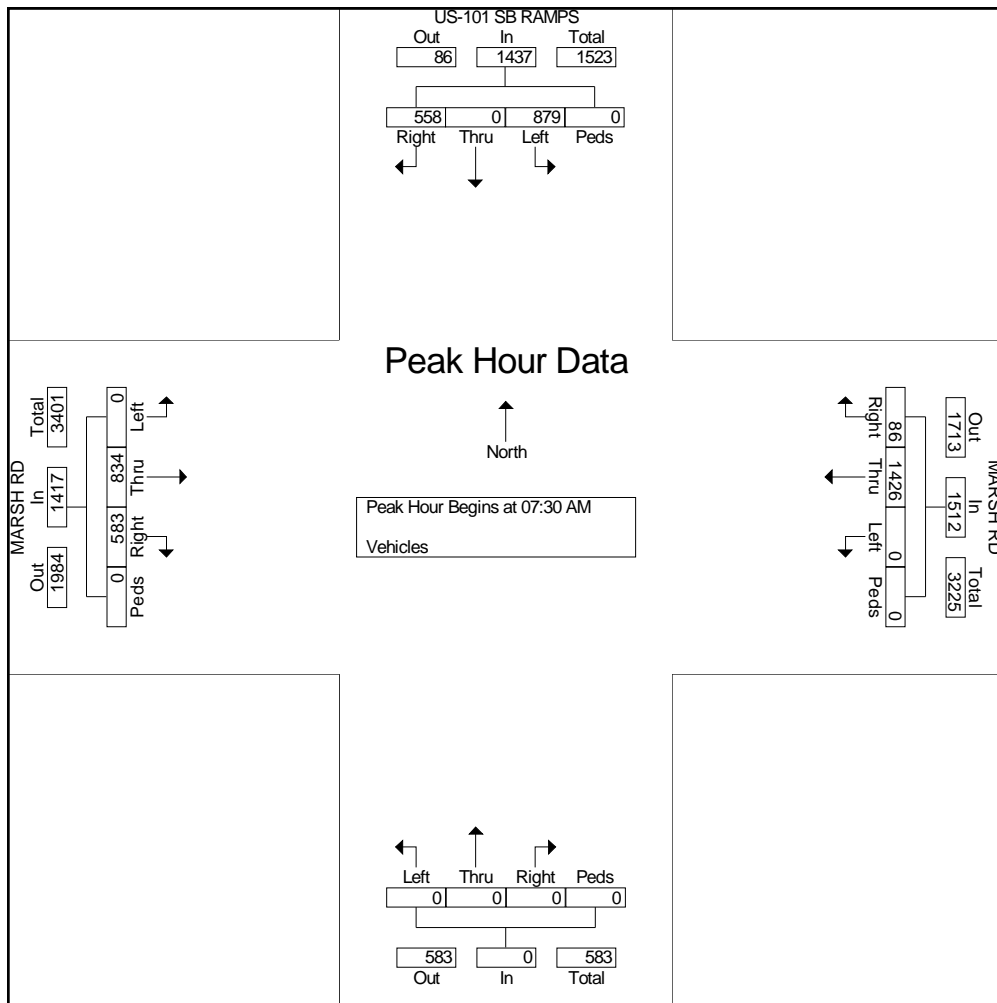

# Traffic Data Service

Campbell, CA  
 (408) 377-2988  
 tdsbay@cs.com

File Name : 27PM FINAL  
 Site Code : 00000027  
 Start Date : 11/17/2010  
 Page No : 1

### Groups Printed- Vehicles

Start Time	US-101 SB RAMPS Southbound					MARSH RD Westbound					Northbound					MARSH RD Eastbound					Int. Total
	Right	Thru	Left	Peds	App. Total	Right	Thru	Left	Peds	App. Total	Right	Thru	Left	Peds	App. Total	Right	Thru	Left	Peds	App. Total	
04:00 PM	108	0	295	0	403	61	201	0	0	262	0	0	0	0	0	122	311	0	0	433	1098
04:15 PM	124	0	364	0	488	45	199	0	0	244	0	0	0	0	0	139	270	0	0	409	1141
04:30 PM	107	0	325	0	432	72	235	0	0	307	0	0	0	0	0	159	314	0	0	473	1212
04:45 PM	124	0	381	0	505	59	235	0	0	294	0	0	0	0	0	158	263	0	0	421	1220
<b>Total</b>	<b>463</b>	<b>0</b>	<b>1365</b>	<b>0</b>	<b>1828</b>	<b>237</b>	<b>870</b>	<b>0</b>	<b>0</b>	<b>1107</b>	<b>0</b>	<b>0</b>	<b>0</b>	<b>0</b>	<b>0</b>	<b>578</b>	<b>1158</b>	<b>0</b>	<b>0</b>	<b>1736</b>	<b>4671</b>
05:00 PM	137	0	353	0	490	80	233	0	0	313	0	0	0	0	0	164	291	0	0	455	1258
05:15 PM	85	0	296	0	381	71	237	0	0	308	0	0	0	0	0	170	313	0	0	483	1172
05:30 PM	122	0	348	0	470	71	211	0	0	282	0	0	0	0	0	163	282	0	0	445	1197
05:45 PM	119	0	367	0	486	62	227	0	0	289	0	0	0	0	0	117	216	0	0	333	1108
<b>Total</b>	<b>463</b>	<b>0</b>	<b>1364</b>	<b>0</b>	<b>1827</b>	<b>284</b>	<b>908</b>	<b>0</b>	<b>0</b>	<b>1192</b>	<b>0</b>	<b>0</b>	<b>0</b>	<b>0</b>	<b>0</b>	<b>614</b>	<b>1102</b>	<b>0</b>	<b>0</b>	<b>1716</b>	<b>4735</b>
Grand Total	926	0	2729	0	3655	521	1778	0	0	2299	0	0	0	0	0	1192	2260	0	0	3452	9406
Apprch %	25.3	0	74.7	0		22.7	77.3	0	0		0	0	0	0		34.5	65.5	0	0		
Total %	9.8	0	29	0	38.9	5.5	18.9	0	0	24.4	0	0	0	0		12.7	24	0	0	36.7	

Start Time	US-101 SB RAMPS Southbound					MARSH RD Westbound					Northbound					MARSH RD Eastbound					Int. Total
	Right	Thru	Left	Peds	App. Total	Right	Thru	Left	Peds	App. Total	Right	Thru	Left	Peds	App. Total	Right	Thru	Left	Peds	App. Total	
Peak Hour Analysis From 04:00 PM to 05:45 PM - Peak 1 of 1																					
Peak Hour for Entire Intersection Begins at 04:30 PM																					
04:30 PM	107	0	325	0	432	72	235	0	0	307	0	0	0	0	0	159	314	0	0	473	1212
04:45 PM	124	0	381	0	505	59	235	0	0	294	0	0	0	0	0	158	263	0	0	421	1220
05:00 PM	137	0	353	0	490	80	233	0	0	313	0	0	0	0	0	164	291	0	0	455	1258
05:15 PM	85	0	296	0	381	71	237	0	0	308	0	0	0	0	0	170	313	0	0	483	1172
Total Volume	453	0	1355	0	1808	282	940	0	0	1222	0	0	0	0	0	651	1181	0	0	1832	4862
% App. Total																					
PHF	.827	.000	.889	.000	.895	.881	.992	.000	.000	.976	.000	.000	.000	.000	.000	.957	.940	.000	.000	.948	.966

# Traffic Data Service

Campbell, CA  
 (408) 377-2988  
 tdsbay@cs.com

File Name : 27PM FINAL  
 Site Code : 00000027  
 Start Date : 11/17/2010  
 Page No : 2

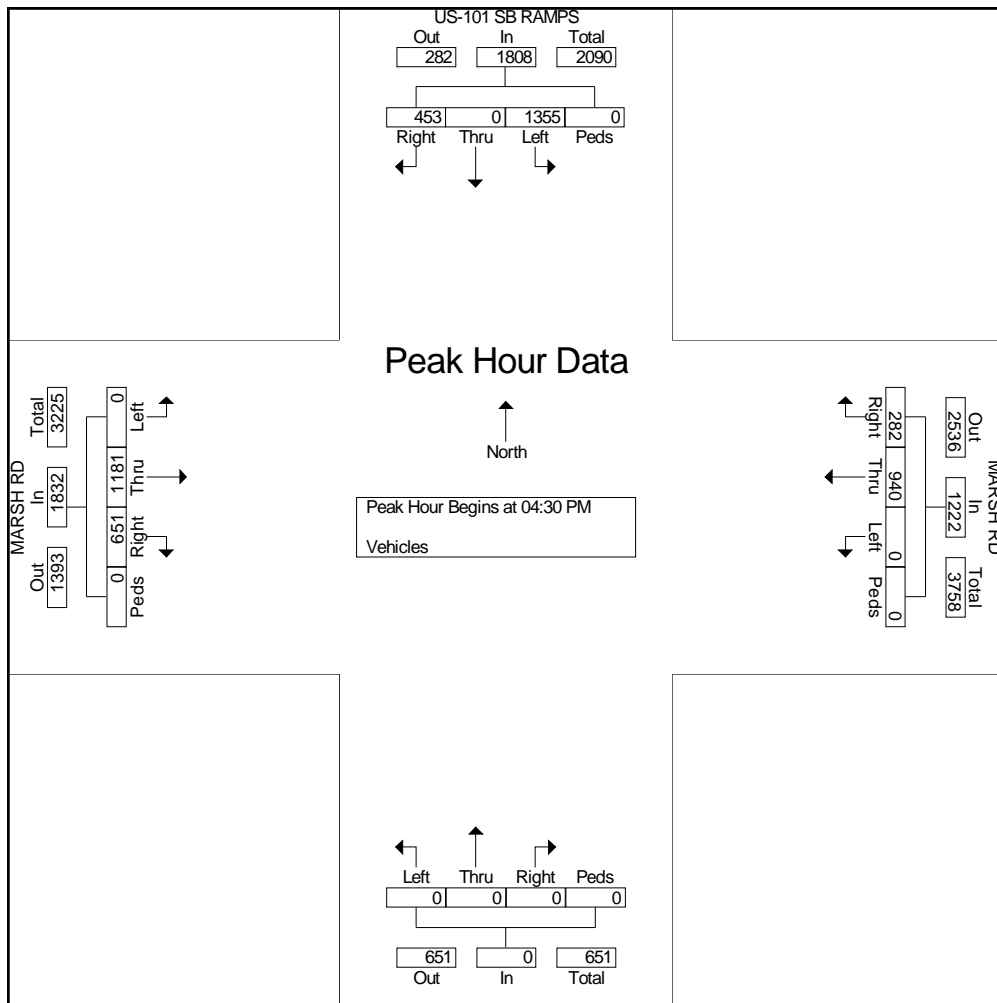

# Traffic Data Service

Campbell, CA  
(408) 377-2988  
tdsbay@cs.com

File Name : 28AM FINAL  
Site Code : 00000028  
Start Date : 11/17/2010  
Page No : 1

### Groups Printed- Bikes

Start Time	SCOTT DR Southbound					MARSH RD Westbound					SCOTT DR Northbound					MARSH RD Eastbound					Int. Total	
	Right	Thru	Left	Peds	App. Total	Right	Thru	Left	Peds	App. Total	Right	Thru	Left	Peds	App. Total	Right	Thru	Left	Peds	App. Total		
07:00 AM	0	0	0	0	0	0	0	0	0	0	0	0	0	0	0	0	0	0	0	0	0	0
07:15 AM	0	0	0	0	0	0	0	0	0	0	0	0	0	0	0	0	0	0	0	0	0	0
07:30 AM	0	0	0	0	0	0	0	0	0	0	0	0	0	0	0	0	0	0	0	0	0	0
07:45 AM	0	0	0	0	0	0	0	0	0	0	0	0	0	0	0	0	0	0	0	0	0	0
<b>Total</b>	0	0	0	0	0	0	0	0	0	0	0	0	0	0	0	0	0	0	0	0	0	0
08:00 AM	0	0	0	0	0	0	0	0	0	0	0	0	0	0	0	0	0	0	0	0	0	0
08:15 AM	0	0	0	0	0	0	0	0	0	0	0	0	0	0	0	0	0	0	0	0	0	0
08:30 AM	0	0	0	0	0	0	0	0	0	0	0	0	0	0	0	0	0	0	0	0	0	0
08:45 AM	0	0	0	0	0	0	0	0	0	0	0	0	0	0	0	0	0	0	0	0	0	0
<b>Total</b>	0	0	0	0	0	0	0	0	0	0	0	0	0	0	0	0	0	0	0	0	0	0
Grand Total	0	0	0	0	0	0	0	0	0	0	0	0	0	0	0	0	0	0	0	0	0	0
Apprch %	0	0	0	0		0	0	0	0		0	0	0	0		0	0	0	0			
Total %																						

Start Time	SCOTT DR Southbound					MARSH RD Westbound					SCOTT DR Northbound					MARSH RD Eastbound					Int. Total	
	Right	Thru	Left	Peds	App. Total	Right	Thru	Left	Peds	App. Total	Right	Thru	Left	Peds	App. Total	Right	Thru	Left	Peds	App. Total		
Peak Hour Analysis From 07:00 AM to 08:45 AM - Peak 1 of 1																						
Peak Hour for Entire Intersection Begins at 07:00 AM																						
07:00 AM	0	0	0	0	0	0	0	0	0	0	0	0	0	0	0	0	0	0	0	0	0	0
07:15 AM	0	0	0	0	0	0	0	0	0	0	0	0	0	0	0	0	0	0	0	0	0	0
07:30 AM	0	0	0	0	0	0	0	0	0	0	0	0	0	0	0	0	0	0	0	0	0	0
07:45 AM	0	0	0	0	0	0	0	0	0	0	0	0	0	0	0	0	0	0	0	0	0	0
Total Volume	0	0	0	0	0	0	0	0	0	0	0	0	0	0	0	0	0	0	0	0	0	0
% App. Total	0	0	0	0		0	0	0	0		0	0	0	0		0	0	0	0			
PHF	.000	.000	.000	.000	.000	.000	.000	.000	.000	.000	.000	.000	.000	.000	.000	.000	.000	.000	.000	.000	.000	.000



# Traffic Data Service

Campbell, CA  
(408) 377-2988  
tdsbay@cs.com

File Name : 28AM FINAL  
Site Code : 00000028  
Start Date : 11/17/2010  
Page No : 2

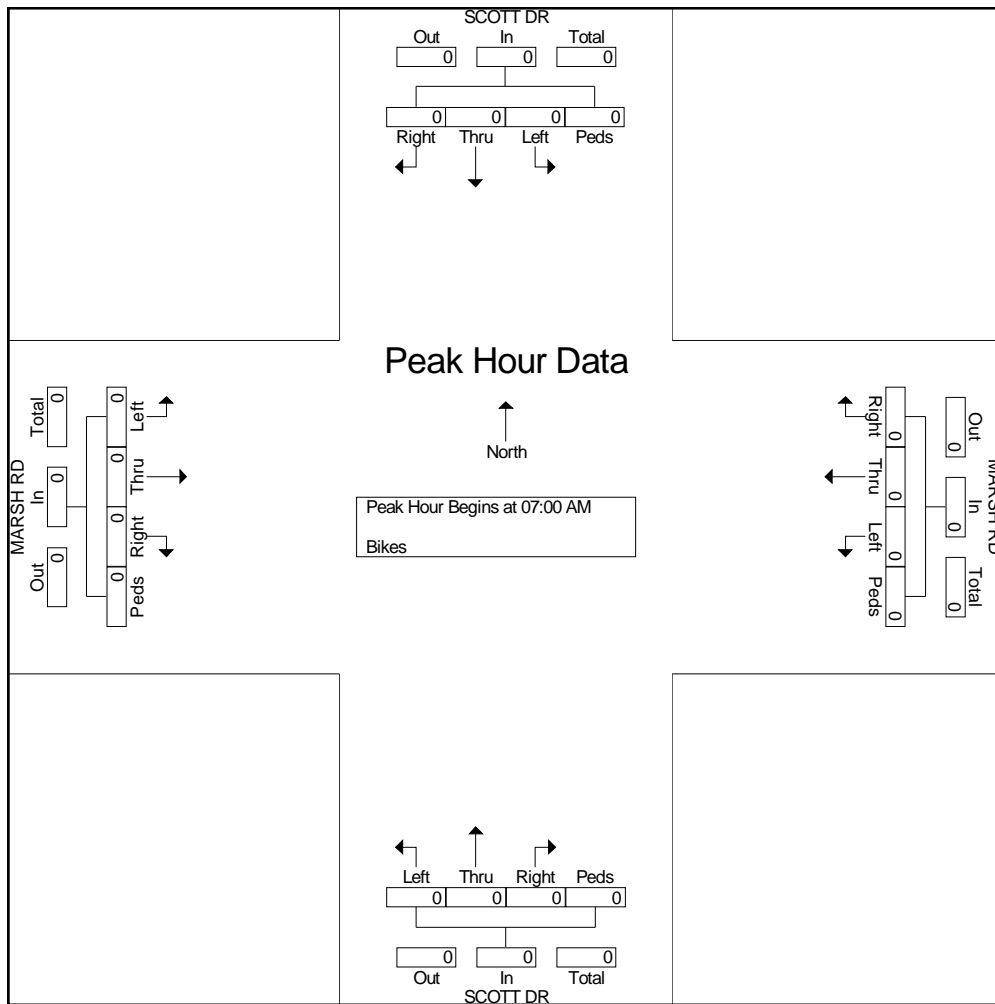

# Traffic Data Service

Campbell, CA  
(408) 377-2988  
tdsbay@cs.com

File Name : 28PM FINAL  
Site Code : 00000028  
Start Date : 11/17/2010  
Page No : 1

### Groups Printed- Vehicles

Start Time	SCOTT DR Southbound					MARSH RD Westbound					SCOTT DR Northbound					MARSH RD Eastbound					Int. Total
	Right	Thru	Left	Peds	App. Total	Right	Thru	Left	Peds	App. Total	Right	Thru	Left	Peds	App. Total	Right	Thru	Left	Peds	App. Total	
04:00 PM	1	1	42	0	44	53	272	11	0	336	51	1	9	0	61	5	339	14	0	358	799
04:15 PM	0	4	42	0	46	48	229	18	0	295	53	2	8	0	63	2	298	60	0	360	764
04:30 PM	1	3	60	0	64	63	261	27	0	351	73	9	6	0	88	4	353	6	0	363	866
04:45 PM	1	3	55	0	59	53	287	14	0	354	45	2	6	0	53	5	310	8	0	323	789
<b>Total</b>	<b>3</b>	<b>11</b>	<b>199</b>	<b>0</b>	<b>213</b>	<b>217</b>	<b>1049</b>	<b>70</b>	<b>0</b>	<b>1336</b>	<b>222</b>	<b>14</b>	<b>29</b>	<b>0</b>	<b>265</b>	<b>16</b>	<b>1300</b>	<b>88</b>	<b>0</b>	<b>1404</b>	<b>3218</b>
05:00 PM	0	1	63	0	64	45	285	22	0	352	89	0	7	0	96	4	294	17	0	315	827
05:15 PM	0	2	76	0	78	53	276	15	0	344	60	4	9	0	73	4	357	11	0	372	867
05:30 PM	0	2	57	0	59	55	249	9	0	313	72	3	12	0	87	6	330	13	0	349	808
05:45 PM	0	6	44	0	50	54	259	5	0	318	43	2	9	0	54	2	231	5	0	238	660
<b>Total</b>	<b>0</b>	<b>11</b>	<b>240</b>	<b>0</b>	<b>251</b>	<b>207</b>	<b>1069</b>	<b>51</b>	<b>0</b>	<b>1327</b>	<b>264</b>	<b>9</b>	<b>37</b>	<b>0</b>	<b>310</b>	<b>16</b>	<b>1212</b>	<b>46</b>	<b>0</b>	<b>1274</b>	<b>3162</b>
Grand Total	3	22	439	0	464	424	2118	121	0	2663	486	23	66	0	575	32	2512	134	0	2678	6380
Apprch %	0.6	4.7	94.6	0		15.9	79.5	4.5	0		84.5	4	11.5	0		1.2	93.8	5	0		
Total %	0	0.3	6.9	0	7.3	6.6	33.2	1.9	0	41.7	7.6	0.4	1	0	9	0.5	39.4	2.1	0	42	

Start Time	SCOTT DR Southbound					MARSH RD Westbound					SCOTT DR Northbound					MARSH RD Eastbound					Int. Total
	Right	Thru	Left	Peds	App. Total	Right	Thru	Left	Peds	App. Total	Right	Thru	Left	Peds	App. Total	Right	Thru	Left	Peds	App. Total	
Peak Hour Analysis From 04:00 PM to 05:45 PM - Peak 1 of 1																					
Peak Hour for Entire Intersection Begins at 04:30 PM																					
04:30 PM	1	3	60	0	64	63	261	27	0	351	73	9	6	0	88	4	353	6	0	363	866
04:45 PM	1	3	55	0	59	53	287	14	0	354	45	2	6	0	53	5	310	8	0	323	789
05:00 PM	0	1	63	0	64	45	285	22	0	352	89	0	7	0	96	4	294	17	0	315	827
05:15 PM	0	2	76	0	78	53	276	15	0	344	60	4	9	0	73	4	357	11	0	372	867
Total Volume	2	9	254	0	265	214	1109	78	0	1401	267	15	28	0	310	17	1314	42	0	1373	3349
% App. Total																					
PHF	.500	.750	.836	.000	.849	.849	.966	.722	.000	.989	.750	.417	.778	.000	.807	.850	.920	.618	.000	.923	.966

# Traffic Data Service

Campbell, CA  
 (408) 377-2988  
 tdsbay@cs.com

File Name : 28PM FINAL  
 Site Code : 00000028  
 Start Date : 11/17/2010  
 Page No : 2

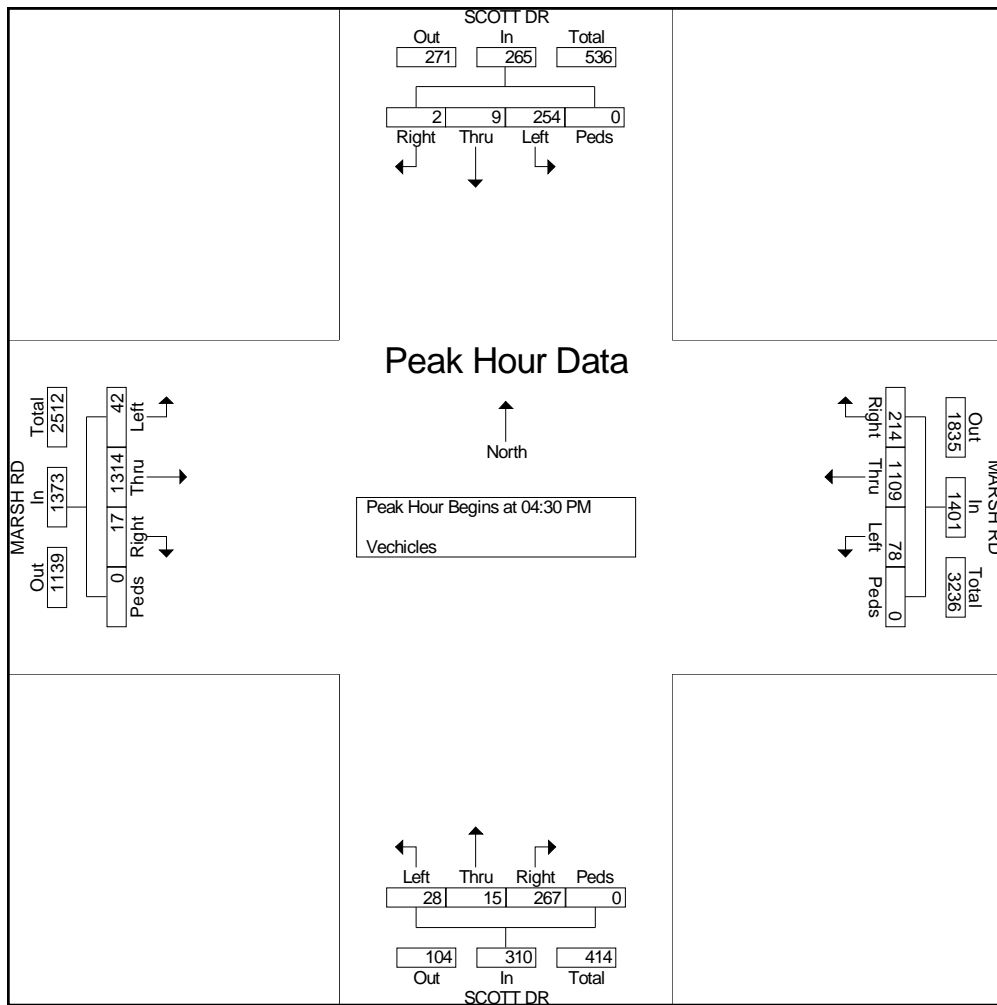

# Traffic Data Service

Campbell, CA  
(408) 377-2988  
tdsbay@cs.com

File Name : 29AM FINAL  
Site Code : 00000029  
Start Date : 11/17/2010  
Page No : 1

### Groups Printed- Vehicles

Start Time	FLORENCE ST Southbound					MARSH RD Westbound					BOHANNON DR Northbound					MARSH RD Eastbound					Int. Total
	Right	Thru	Left	Peds	App. Total	Right	Thru	Left	Peds	App. Total	Right	Thru	Left	Peds	App. Total	Right	Thru	Left	Peds	App. Total	
07:00 AM	12	5	77	0	94	56	169	10	0	235	5	1	8	0	14	6	138	13	0	157	500
07:15 AM	5	11	84	0	100	75	205	11	0	291	4	4	6	0	14	12	201	11	0	224	629
07:30 AM	12	3	119	0	134	88	316	7	0	411	2	3	6	0	11	12	176	12	0	200	756
07:45 AM	19	12	84	0	115	90	302	11	0	403	3	3	4	0	10	13	195	46	0	254	782
<b>Total</b>	<b>48</b>	<b>31</b>	<b>364</b>	<b>0</b>	<b>443</b>	<b>309</b>	<b>992</b>	<b>39</b>	<b>0</b>	<b>1340</b>	<b>14</b>	<b>11</b>	<b>24</b>	<b>0</b>	<b>49</b>	<b>43</b>	<b>710</b>	<b>82</b>	<b>0</b>	<b>835</b>	<b>2667</b>
08:00 AM	42	9	104	0	155	77	288	11	0	376	1	0	1	0	2	15	205	34	0	254	787
08:15 AM	18	6	83	0	107	68	235	17	0	320	2	3	4	0	9	18	220	25	0	263	699
08:30 AM	29	3	82	0	114	54	233	11	0	298	3	0	0	0	3	25	230	16	0	271	686
08:45 AM	48	11	58	0	117	73	239	7	0	319	1	1	6	0	8	14	167	37	0	218	662
<b>Total</b>	<b>137</b>	<b>29</b>	<b>327</b>	<b>0</b>	<b>493</b>	<b>272</b>	<b>995</b>	<b>46</b>	<b>0</b>	<b>1313</b>	<b>7</b>	<b>4</b>	<b>11</b>	<b>0</b>	<b>22</b>	<b>72</b>	<b>822</b>	<b>112</b>	<b>0</b>	<b>1006</b>	<b>2834</b>
<b>Grand Total</b>	<b>185</b>	<b>60</b>	<b>691</b>	<b>0</b>	<b>936</b>	<b>581</b>	<b>1987</b>	<b>85</b>	<b>0</b>	<b>2653</b>	<b>21</b>	<b>15</b>	<b>35</b>	<b>0</b>	<b>71</b>	<b>115</b>	<b>1532</b>	<b>194</b>	<b>0</b>	<b>1841</b>	<b>5501</b>
<b>Apprch %</b>	<b>19.8</b>	<b>6.4</b>	<b>73.8</b>	<b>0</b>		<b>21.9</b>	<b>74.9</b>	<b>3.2</b>	<b>0</b>		<b>29.6</b>	<b>21.1</b>	<b>49.3</b>	<b>0</b>		<b>6.2</b>	<b>83.2</b>	<b>10.5</b>	<b>0</b>		
<b>Total %</b>	<b>3.4</b>	<b>1.1</b>	<b>12.6</b>	<b>0</b>	<b>17</b>	<b>10.6</b>	<b>36.1</b>	<b>1.5</b>	<b>0</b>	<b>48.2</b>	<b>0.4</b>	<b>0.3</b>	<b>0.6</b>	<b>0</b>	<b>1.3</b>	<b>2.1</b>	<b>27.8</b>	<b>3.5</b>	<b>0</b>	<b>33.5</b>	

Start Time	FLORENCE ST Southbound					MARSH RD Westbound					BOHANNON DR Northbound					MARSH RD Eastbound					Int. Total
	Right	Thru	Left	Peds	App. Total	Right	Thru	Left	Peds	App. Total	Right	Thru	Left	Peds	App. Total	Right	Thru	Left	Peds	App. Total	
Peak Hour Analysis From 07:00 AM to 08:45 AM - Peak 1 of 1																					
Peak Hour for Entire Intersection Begins at 07:30 AM																					
07:30 AM	12	3	119	0	134	88	316	7	0	411	2	3	6	0	11	12	176	12	0	200	756
07:45 AM	19	12	84	0	115	90	302	11	0	403	3	3	4	0	10	13	195	46	0	254	782
08:00 AM	42	9	104	0	155	77	288	11	0	376	1	0	1	0	2	15	205	34	0	254	787
08:15 AM	18	6	83	0	107	68	235	17	0	320	2	3	4	0	9	18	220	25	0	263	699
<b>Total Volume</b>	<b>91</b>	<b>30</b>	<b>390</b>	<b>0</b>	<b>511</b>	<b>323</b>	<b>1141</b>	<b>46</b>	<b>0</b>	<b>1510</b>	<b>8</b>	<b>9</b>	<b>15</b>	<b>0</b>	<b>32</b>	<b>58</b>	<b>796</b>	<b>117</b>	<b>0</b>	<b>971</b>	<b>3024</b>
<b>% App. Total</b>																					
<b>PHF</b>	<b>.542</b>	<b>.625</b>	<b>.819</b>	<b>.000</b>	<b>.824</b>	<b>.897</b>	<b>.903</b>	<b>.676</b>	<b>.000</b>	<b>.918</b>	<b>.667</b>	<b>.750</b>	<b>.625</b>	<b>.000</b>	<b>.727</b>	<b>.806</b>	<b>.905</b>	<b>.636</b>	<b>.000</b>	<b>.923</b>	<b>.961</b>

# Traffic Data Service

Campbell, CA  
 (408) 377-2988  
 tdsbay@cs.com

File Name : 29AM FINAL  
 Site Code : 00000029  
 Start Date : 11/17/2010  
 Page No : 2

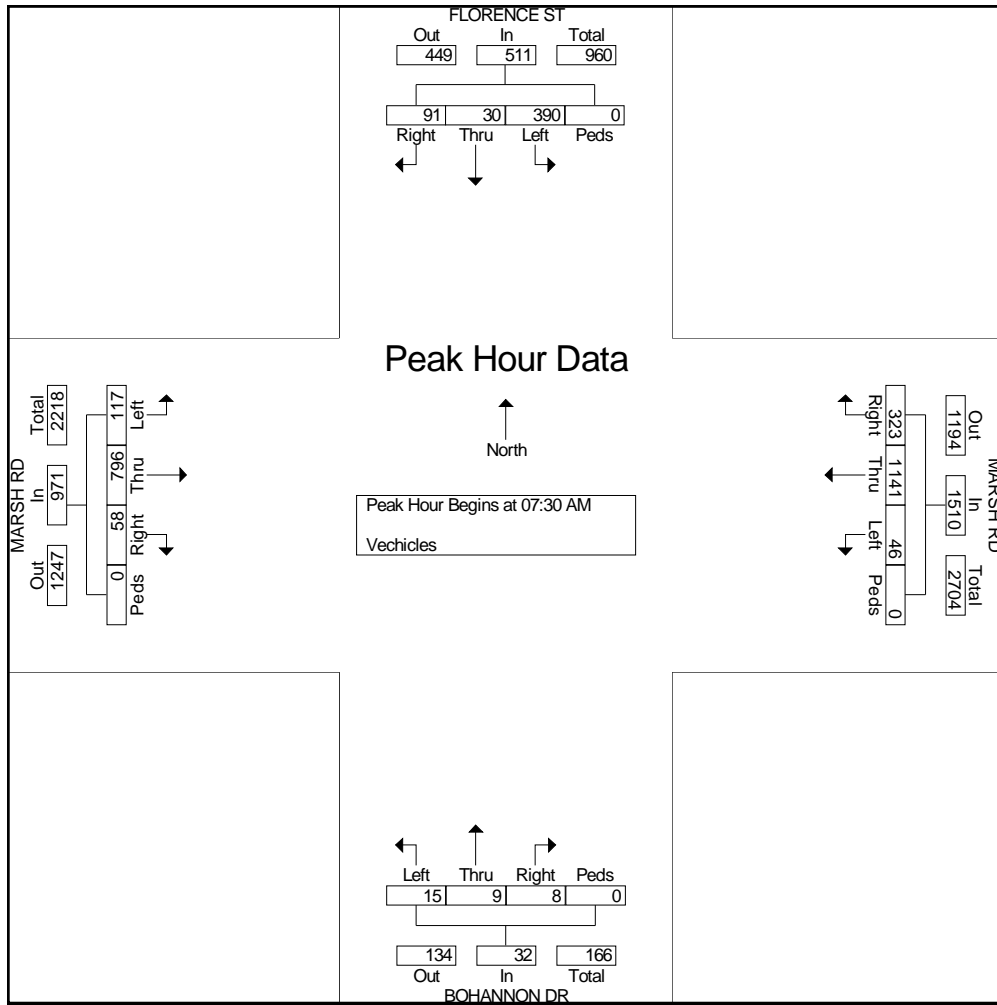

# Traffic Data Service

Campbell, CA  
(408) 377-2988  
tdsbay@cs.com

File Name : 29PM FINAL  
Site Code : 00000029  
Start Date : 11/17/2010  
Page No : 1

### Groups Printed- Vehicles

Start Time	FLORENCE ST Southbound					MARSH RD Westbound					BOHANNON DR Northbound					MARSH RD Eastbound					Int. Total
	Right	Thru	Left	Peds	App. Total	Right	Thru	Left	Peds	App. Total	Right	Thru	Left	Peds	App. Total	Right	Thru	Left	Peds	App. Total	
04:00 PM	22	6	102	0	130	85	182	10	0	277	27	8	11	0	46	49	203	36	0	288	741
04:15 PM	24	2	104	0	130	71	183	13	0	267	7	4	12	0	23	27	205	78	0	310	730
04:30 PM	20	9	88	0	117	94	189	5	0	288	18	6	12	0	36	15	215	59	0	289	730
04:45 PM	27	2	93	0	122	97	197	9	0	303	17	8	11	0	36	15	238	49	0	302	763
<b>Total</b>	<b>93</b>	<b>19</b>	<b>387</b>	<b>0</b>	<b>499</b>	<b>347</b>	<b>751</b>	<b>37</b>	<b>0</b>	<b>1135</b>	<b>69</b>	<b>26</b>	<b>46</b>	<b>0</b>	<b>141</b>	<b>106</b>	<b>861</b>	<b>222</b>	<b>0</b>	<b>1189</b>	<b>2964</b>
05:00 PM	31	4	116	0	151	76	206	5	0	287	15	12	29	0	56	13	211	72	0	296	790
05:15 PM	22	3	117	0	142	81	224	10	0	315	18	6	23	0	47	7	209	51	0	267	771
05:30 PM	48	21	102	0	171	62	206	2	0	270	8	6	32	0	46	20	227	67	0	314	801
05:45 PM	36	1	98	0	135	72	221	3	0	296	8	4	21	0	33	16	141	39	0	196	660
<b>Total</b>	<b>137</b>	<b>29</b>	<b>433</b>	<b>0</b>	<b>599</b>	<b>291</b>	<b>857</b>	<b>20</b>	<b>0</b>	<b>1168</b>	<b>49</b>	<b>28</b>	<b>105</b>	<b>0</b>	<b>182</b>	<b>56</b>	<b>788</b>	<b>229</b>	<b>0</b>	<b>1073</b>	<b>3022</b>
<b>Grand Total</b>	<b>230</b>	<b>48</b>	<b>820</b>	<b>0</b>	<b>1098</b>	<b>638</b>	<b>1608</b>	<b>57</b>	<b>0</b>	<b>2303</b>	<b>118</b>	<b>54</b>	<b>151</b>	<b>0</b>	<b>323</b>	<b>162</b>	<b>1649</b>	<b>451</b>	<b>0</b>	<b>2262</b>	<b>5986</b>
<b>Apprch %</b>	<b>20.9</b>	<b>4.4</b>	<b>74.7</b>	<b>0</b>		<b>27.7</b>	<b>69.8</b>	<b>2.5</b>	<b>0</b>		<b>36.5</b>	<b>16.7</b>	<b>46.7</b>	<b>0</b>		<b>7.2</b>	<b>72.9</b>	<b>19.9</b>	<b>0</b>		
<b>Total %</b>	<b>3.8</b>	<b>0.8</b>	<b>13.7</b>	<b>0</b>	<b>18.3</b>	<b>10.7</b>	<b>26.9</b>	<b>1</b>	<b>0</b>	<b>38.5</b>	<b>2</b>	<b>0.9</b>	<b>2.5</b>	<b>0</b>	<b>5.4</b>	<b>2.7</b>	<b>27.5</b>	<b>7.5</b>	<b>0</b>	<b>37.8</b>	

Start Time	FLORENCE ST Southbound					MARSH RD Westbound					BOHANNON DR Northbound					MARSH RD Eastbound					Int. Total
	Right	Thru	Left	Peds	App. Total	Right	Thru	Left	Peds	App. Total	Right	Thru	Left	Peds	App. Total	Right	Thru	Left	Peds	App. Total	
Peak Hour Analysis From 04:00 PM to 05:45 PM - Peak 1 of 1																					
Peak Hour for Entire Intersection Begins at 04:45 PM																					
04:45 PM	27	2	93	0	122	97	197	9	0	303	17	8	11	0	36	15	238	49	0	302	763
05:00 PM	31	4	116	0	151	76	206	5	0	287	15	12	29	0	56	13	211	72	0	296	790
05:15 PM	22	3	117	0	142	81	224	10	0	315	18	6	23	0	47	7	209	51	0	267	771
05:30 PM	48	21	102	0	171	62	206	2	0	270	8	6	32	0	46	20	227	67	0	314	801
<b>Total Volume</b>	<b>128</b>	<b>30</b>	<b>428</b>	<b>0</b>	<b>586</b>	<b>316</b>	<b>833</b>	<b>26</b>	<b>0</b>	<b>1175</b>	<b>58</b>	<b>32</b>	<b>95</b>	<b>0</b>	<b>185</b>	<b>55</b>	<b>885</b>	<b>239</b>	<b>0</b>	<b>1179</b>	<b>3125</b>
<b>% App. Total</b>	<b>21.8</b>	<b>5.1</b>	<b>73</b>	<b>0</b>		<b>26.9</b>	<b>70.9</b>	<b>2.2</b>	<b>0</b>		<b>31.4</b>	<b>17.3</b>	<b>51.4</b>	<b>0</b>		<b>4.7</b>	<b>75.1</b>	<b>20.3</b>	<b>0</b>		
<b>PHF</b>	<b>.667</b>	<b>.357</b>	<b>.915</b>	<b>.000</b>	<b>.857</b>	<b>.814</b>	<b>.930</b>	<b>.650</b>	<b>.000</b>	<b>.933</b>	<b>.806</b>	<b>.667</b>	<b>.742</b>	<b>.000</b>	<b>.826</b>	<b>.688</b>	<b>.930</b>	<b>.830</b>	<b>.000</b>	<b>.939</b>	<b>.975</b>

# Traffic Data Service

Campbell, CA  
 (408) 377-2988  
 tdsbay@cs.com

File Name : 29PM FINAL  
 Site Code : 00000029  
 Start Date : 11/17/2010  
 Page No : 2

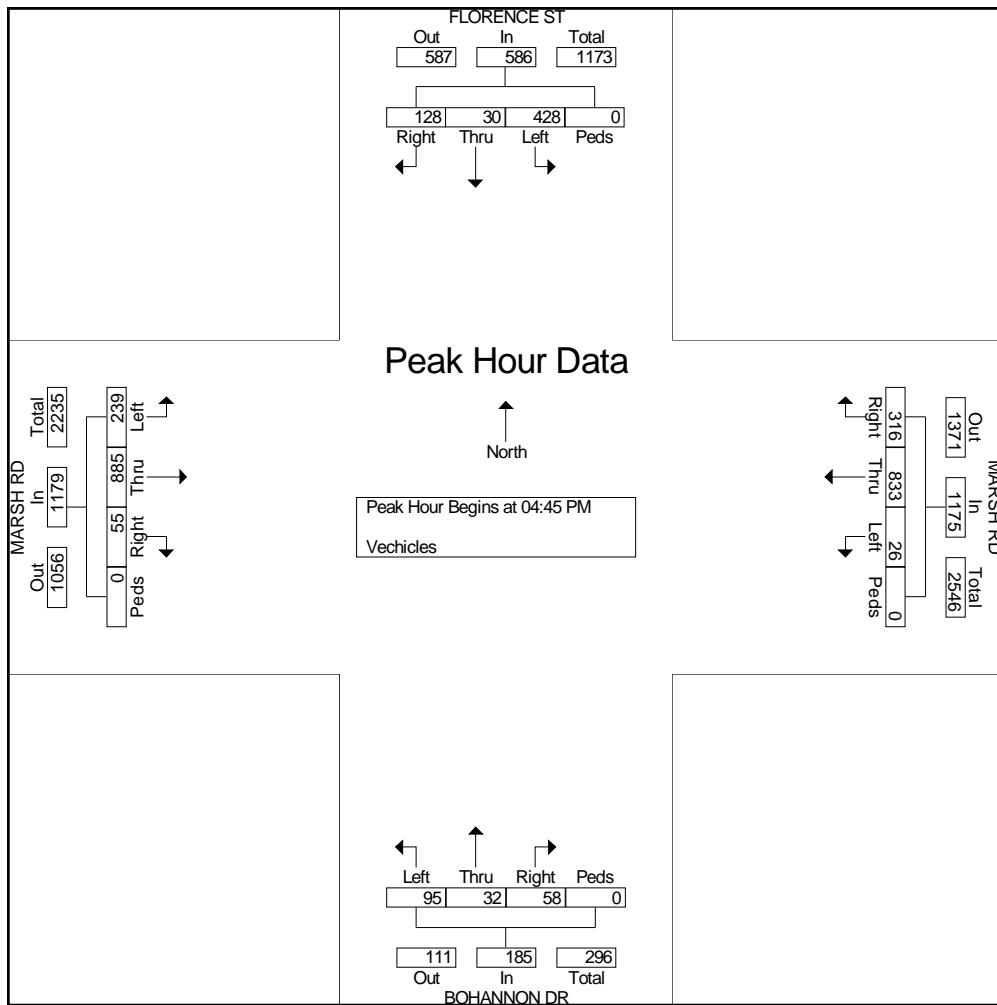

# Traffic Data Service

Campbell, CA  
(408) 377-2988  
tdsbay@cs.com

File Name : 30AM FINAL  
Site Code : 00000030  
Start Date : 11/17/2010  
Page No : 1

### Groups Printed- Vehicles

Start Time	BAY RD Southbound					MARSH RD Westbound					BAY RD Northbound					MARSH RD Eastbound					Int. Total
	Right	Thru	Left	Peds	App. Total	Right	Thru	Left	Peds	App. Total	Right	Thru	Left	Peds	App. Total	Right	Thru	Left	Peds	App. Total	
07:00 AM	2	2	12	0	16	2	159	24	0	185	22	0	6	0	28	5	139	0	0	144	373
07:15 AM	0	5	26	0	31	2	200	24	0	226	24	0	8	0	32	13	143	0	0	156	445
07:30 AM	1	6	29	0	36	3	295	43	0	341	42	0	25	0	67	9	132	1	0	142	586
07:45 AM	1	9	35	0	45	8	257	74	0	339	49	1	24	0	74	12	154	0	0	166	624
<b>Total</b>	<b>4</b>	<b>22</b>	<b>102</b>	<b>0</b>	<b>128</b>	<b>15</b>	<b>911</b>	<b>165</b>	<b>0</b>	<b>1091</b>	<b>137</b>	<b>1</b>	<b>63</b>	<b>0</b>	<b>201</b>	<b>39</b>	<b>568</b>	<b>1</b>	<b>0</b>	<b>608</b>	<b>2028</b>
08:00 AM	0	7	29	0	36	7	227	80	0	314	37	2	11	0	50	25	197	1	0	223	623
08:15 AM	3	6	19	0	28	4	203	67	0	274	49	0	10	0	59	20	182	0	0	202	563
08:30 AM	2	9	23	0	34	8	179	67	0	254	49	1	22	0	72	16	170	2	0	188	548
08:45 AM	0	10	25	0	35	4	236	84	0	324	40	3	19	0	62	14	212	0	0	226	647
<b>Total</b>	<b>5</b>	<b>32</b>	<b>96</b>	<b>0</b>	<b>133</b>	<b>23</b>	<b>845</b>	<b>298</b>	<b>0</b>	<b>1166</b>	<b>175</b>	<b>6</b>	<b>62</b>	<b>0</b>	<b>243</b>	<b>75</b>	<b>761</b>	<b>3</b>	<b>0</b>	<b>839</b>	<b>2381</b>
<b>Grand Total</b>	<b>9</b>	<b>54</b>	<b>198</b>	<b>0</b>	<b>261</b>	<b>38</b>	<b>1756</b>	<b>463</b>	<b>0</b>	<b>2257</b>	<b>312</b>	<b>7</b>	<b>125</b>	<b>0</b>	<b>444</b>	<b>114</b>	<b>1329</b>	<b>4</b>	<b>0</b>	<b>1447</b>	<b>4409</b>
<b>Apprch %</b>	<b>3.4</b>	<b>20.7</b>	<b>75.9</b>	<b>0</b>		<b>1.7</b>	<b>77.8</b>	<b>20.5</b>	<b>0</b>		<b>70.3</b>	<b>1.6</b>	<b>28.2</b>	<b>0</b>		<b>7.9</b>	<b>91.8</b>	<b>0.3</b>	<b>0</b>		
<b>Total %</b>	<b>0.2</b>	<b>1.2</b>	<b>4.5</b>	<b>0</b>	<b>5.9</b>	<b>0.9</b>	<b>39.8</b>	<b>10.5</b>	<b>0</b>	<b>51.2</b>	<b>7.1</b>	<b>0.2</b>	<b>2.8</b>	<b>0</b>	<b>10.1</b>	<b>2.6</b>	<b>30.1</b>	<b>0.1</b>	<b>0</b>	<b>32.8</b>	

Start Time	BAY RD Southbound					MARSH RD Westbound					BAY RD Northbound					MARSH RD Eastbound					Int. Total
	Right	Thru	Left	Peds	App. Total	Right	Thru	Left	Peds	App. Total	Right	Thru	Left	Peds	App. Total	Right	Thru	Left	Peds	App. Total	
Peak Hour Analysis From 07:00 AM to 08:45 AM - Peak 1 of 1																					
Peak Hour for Entire Intersection Begins at 07:30 AM																					
07:30 AM	1	6	29	0	36	3	295	43	0	341	42	0	25	0	67	9	132	1	0	142	586
07:45 AM	1	9	35	0	45	8	257	74	0	339	49	1	24	0	74	12	154	0	0	166	624
08:00 AM	0	7	29	0	36	7	227	80	0	314	37	2	11	0	50	25	197	1	0	223	623
08:15 AM	3	6	19	0	28	4	203	67	0	274	49	0	10	0	59	20	182	0	0	202	563
<b>Total Volume</b>	<b>5</b>	<b>28</b>	<b>112</b>	<b>0</b>	<b>145</b>	<b>22</b>	<b>982</b>	<b>264</b>	<b>0</b>	<b>1268</b>	<b>177</b>	<b>3</b>	<b>70</b>	<b>0</b>	<b>250</b>	<b>66</b>	<b>665</b>	<b>2</b>	<b>0</b>	<b>733</b>	<b>2396</b>
<b>% App. Total</b>	<b>3.4</b>	<b>19.3</b>	<b>77.2</b>	<b>0</b>		<b>1.7</b>	<b>77.4</b>	<b>20.8</b>	<b>0</b>		<b>70.8</b>	<b>1.2</b>	<b>28</b>	<b>0</b>		<b>9</b>	<b>90.7</b>	<b>0.3</b>	<b>0</b>		
<b>PHF</b>	<b>.417</b>	<b>.778</b>	<b>.800</b>	<b>.000</b>	<b>.806</b>	<b>.688</b>	<b>.832</b>	<b>.825</b>	<b>.000</b>	<b>.930</b>	<b>.903</b>	<b>.375</b>	<b>.700</b>	<b>.000</b>	<b>.845</b>	<b>.660</b>	<b>.844</b>	<b>.500</b>	<b>.000</b>	<b>.822</b>	<b>.960</b>



# Traffic Data Service

Campbell, CA  
 (408) 377-2988  
 tdsbay@cs.com

File Name : 30AM FINAL  
 Site Code : 00000030  
 Start Date : 11/17/2010  
 Page No : 2

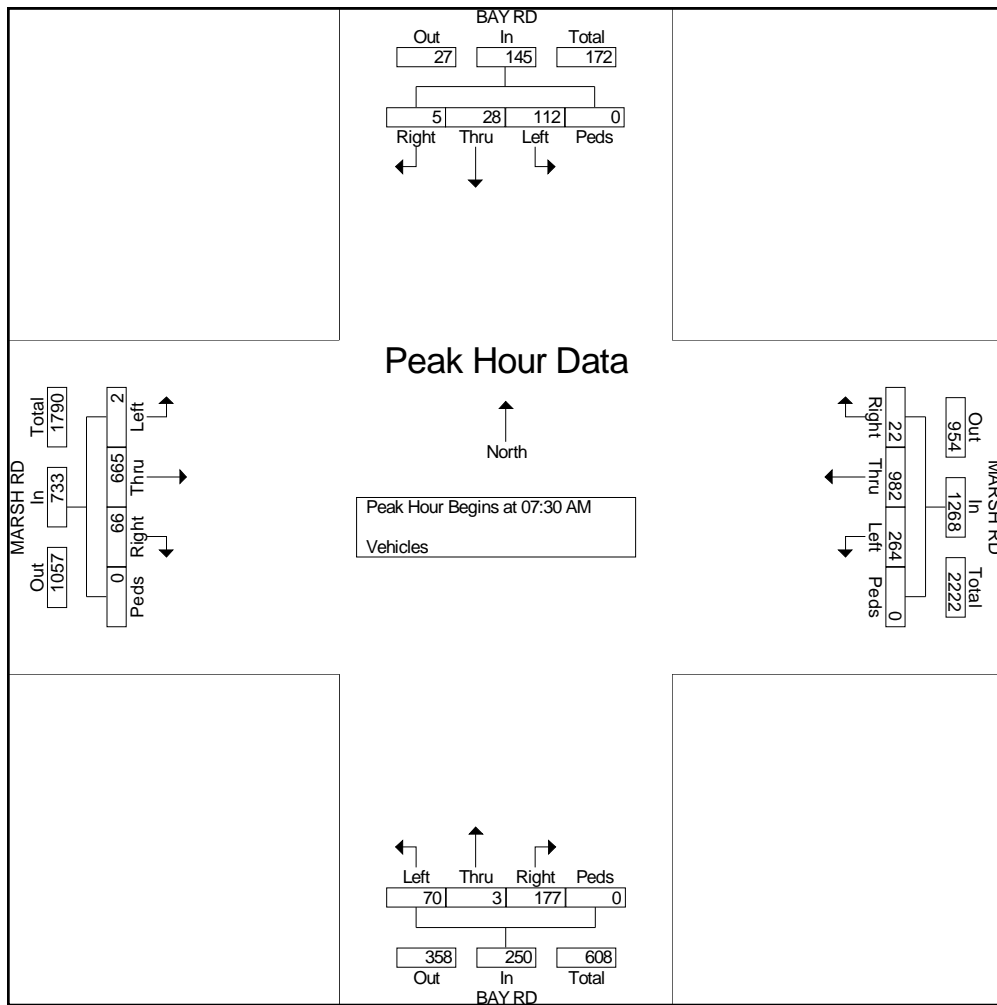

# Traffic Data Service

Campbell, CA  
(408) 377-2988  
tdsbay@cs.com

File Name : 30PM FINAL  
Site Code : 00000030  
Start Date : 11/17/2010  
Page No : 1

### Groups Printed- Vehicles

Start Time	BAY RD Southbound					MARSH RD Westbound					BAY RD Northbound					MARSH RD Eastbound					Int. Total
	Right	Thru	Left	Peds	App. Total	Right	Thru	Left	Peds	App. Total	Right	Thru	Left	Peds	App. Total	Right	Thru	Left	Peds	App. Total	
04:00 PM	0	5	14	0	19	13	175	35	0	223	39	6	18	0	63	18	272	0	0	290	595
04:15 PM	1	6	20	0	27	13	182	31	0	226	41	2	13	0	56	18	251	0	0	269	578
04:30 PM	0	4	14	0	18	13	193	33	0	239	44	0	15	0	59	16	222	0	0	238	554
04:45 PM	1	3	11	0	15	9	183	44	0	236	31	3	13	0	47	18	241	1	0	260	558
<b>Total</b>	<b>2</b>	<b>18</b>	<b>59</b>	<b>0</b>	<b>79</b>	<b>48</b>	<b>733</b>	<b>143</b>	<b>0</b>	<b>924</b>	<b>155</b>	<b>11</b>	<b>59</b>	<b>0</b>	<b>225</b>	<b>70</b>	<b>986</b>	<b>1</b>	<b>0</b>	<b>1057</b>	<b>2285</b>
05:00 PM	0	6	11	0	17	9	218	45	0	272	49	3	12	0	64	25	228	1	0	254	607
05:15 PM	1	6	11	0	18	13	219	49	0	281	56	2	10	0	68	22	192	0	0	214	581
05:30 PM	2	9	18	0	29	9	230	54	0	293	45	3	19	0	67	24	224	1	0	249	638
05:45 PM	0	10	15	0	25	16	224	52	0	292	30	0	16	0	46	19	175	3	0	197	560
<b>Total</b>	<b>3</b>	<b>31</b>	<b>55</b>	<b>0</b>	<b>89</b>	<b>47</b>	<b>891</b>	<b>200</b>	<b>0</b>	<b>1138</b>	<b>180</b>	<b>8</b>	<b>57</b>	<b>0</b>	<b>245</b>	<b>90</b>	<b>819</b>	<b>5</b>	<b>0</b>	<b>914</b>	<b>2386</b>
<b>Grand Total</b>	<b>5</b>	<b>49</b>	<b>114</b>	<b>0</b>	<b>168</b>	<b>95</b>	<b>1624</b>	<b>343</b>	<b>0</b>	<b>2062</b>	<b>335</b>	<b>19</b>	<b>116</b>	<b>0</b>	<b>470</b>	<b>160</b>	<b>1805</b>	<b>6</b>	<b>0</b>	<b>1971</b>	<b>4671</b>
<b>Apprch %</b>	<b>3</b>	<b>29.2</b>	<b>67.9</b>	<b>0</b>		<b>4.6</b>	<b>78.8</b>	<b>16.6</b>	<b>0</b>		<b>71.3</b>	<b>4</b>	<b>24.7</b>	<b>0</b>		<b>8.1</b>	<b>91.6</b>	<b>0.3</b>	<b>0</b>		
<b>Total %</b>	<b>0.1</b>	<b>1</b>	<b>2.4</b>	<b>0</b>	<b>3.6</b>	<b>2</b>	<b>34.8</b>	<b>7.3</b>	<b>0</b>	<b>44.1</b>	<b>7.2</b>	<b>0.4</b>	<b>2.5</b>	<b>0</b>	<b>10.1</b>	<b>3.4</b>	<b>38.6</b>	<b>0.1</b>	<b>0</b>	<b>42.2</b>	

Start Time	BAY RD Southbound					MARSH RD Westbound					BAY RD Northbound					MARSH RD Eastbound					Int. Total
	Right	Thru	Left	Peds	App. Total	Right	Thru	Left	Peds	App. Total	Right	Thru	Left	Peds	App. Total	Right	Thru	Left	Peds	App. Total	
Peak Hour Analysis From 04:00 PM to 05:45 PM - Peak 1 of 1																					
Peak Hour for Entire Intersection Begins at 05:00 PM																					
05:00 PM	0	6	11	0	17	9	218	45	0	272	49	3	12	0	64	25	228	1	0	254	607
05:15 PM	1	6	11	0	18	13	219	49	0	281	56	2	10	0	68	22	192	0	0	214	581
05:30 PM	2	9	18	0	29	9	230	54	0	293	45	3	19	0	67	24	224	1	0	249	638
05:45 PM	0	10	15	0	25	16	224	52	0	292	30	0	16	0	46	19	175	3	0	197	560
<b>Total Volume</b>	<b>3</b>	<b>31</b>	<b>55</b>	<b>0</b>	<b>89</b>	<b>47</b>	<b>891</b>	<b>200</b>	<b>0</b>	<b>1138</b>	<b>180</b>	<b>8</b>	<b>57</b>	<b>0</b>	<b>245</b>	<b>90</b>	<b>819</b>	<b>5</b>	<b>0</b>	<b>914</b>	<b>2386</b>
<b>% App. Total</b>	<b>3.4</b>	<b>34.8</b>	<b>61.8</b>	<b>0</b>		<b>4.1</b>	<b>78.3</b>	<b>17.6</b>	<b>0</b>		<b>73.5</b>	<b>3.3</b>	<b>23.3</b>	<b>0</b>		<b>9.8</b>	<b>89.6</b>	<b>0.5</b>	<b>0</b>		
<b>PHF</b>	<b>.375</b>	<b>.775</b>	<b>.764</b>	<b>.000</b>	<b>.767</b>	<b>.734</b>	<b>.968</b>	<b>.926</b>	<b>.000</b>	<b>.971</b>	<b>.804</b>	<b>.667</b>	<b>.750</b>	<b>.000</b>	<b>.901</b>	<b>.900</b>	<b>.898</b>	<b>.417</b>	<b>.000</b>	<b>.900</b>	<b>.935</b>

# Traffic Data Service

Campbell, CA  
 (408) 377-2988  
 tdsbay@cs.com

File Name : 30PM FINAL  
 Site Code : 00000030  
 Start Date : 11/17/2010  
 Page No : 2

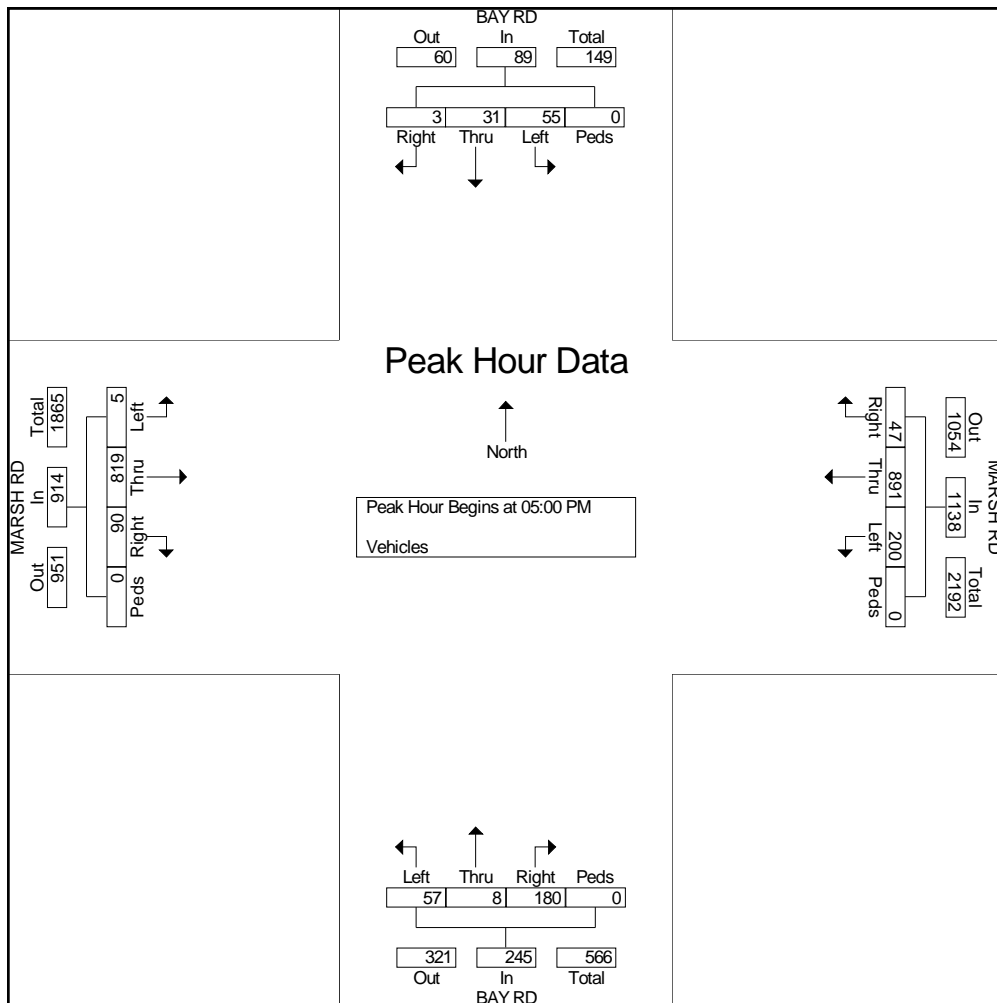

# Traffic Data Service

Campbell, CA  
(408) 377-2988  
tdsbay@cs.com

File Name : 13AM FINAL  
Site Code : 00000013  
Start Date : 11/10/2010  
Page No : 1

### Groups Printed- Vehicles

Start Time	MIDDLEFIELD RD Southbound					MARSH RD Westbound					MIDDLEFIELD RD Northbound					Eastbound					Int. Total
	Right	Thru	Left	Peds	App. Total	Right	Thru	Left	Peds	App. Total	Right	Thru	Left	Peds	App. Total	Right	Thru	Left	Peds	App. Total	
07:00 AM	0	42	64	0	106	69	0	114	0	183	53	14	0	0	67	0	0	0	0	0	356
07:15 AM	0	55	94	0	149	85	0	131	0	216	54	33	0	0	87	0	0	0	0	0	452
07:30 AM	0	90	75	0	165	58	0	158	0	216	80	42	0	0	122	0	0	0	0	0	503
07:45 AM	0	105	74	0	179	45	0	107	0	152	91	38	0	0	129	0	0	0	0	0	460
<b>Total</b>	0	292	307	0	599	257	0	510	0	767	278	127	0	0	405	0	0	0	0	0	1771
08:00 AM	0	90	108	0	198	34	0	92	0	126	106	39	0	0	145	0	0	0	0	0	469
08:15 AM	0	82	85	0	167	32	0	106	0	138	120	47	0	0	167	0	0	0	0	0	472
08:30 AM	0	85	101	0	186	31	0	99	0	130	108	57	0	0	165	0	0	0	0	0	481
08:45 AM	0	97	85	0	182	46	0	93	0	139	84	64	0	0	148	0	0	0	0	0	469
<b>Total</b>	0	354	379	0	733	143	0	390	0	533	418	207	0	0	625	0	0	0	0	0	1891
<b>Grand Total</b>	0	646	686	0	1332	400	0	900	0	1300	696	334	0	0	1030	0	0	0	0	0	3662
Apprch %	0	48.5	51.5	0		30.8	0	69.2	0		67.6	32.4	0	0		0	0	0	0		
Total %	0	17.6	18.7	0	36.4	10.9	0	24.6	0	35.5	19	9.1	0	0	28.1	0	0	0	0	0	

Start Time	MIDDLEFIELD RD Southbound					MARSH RD Westbound					MIDDLEFIELD RD Northbound					Eastbound					Int. Total
	Right	Thru	Left	Peds	App. Total	Right	Thru	Left	Peds	App. Total	Right	Thru	Left	Peds	App. Total	Right	Thru	Left	Peds	App. Total	
Peak Hour Analysis From 07:00 AM to 08:45 AM - Peak 1 of 1																					
Peak Hour for Entire Intersection Begins at 07:30 AM																					
07:30 AM	0	90	75	0	165	58	0	158	0	216	80	42	0	0	122	0	0	0	0	0	503
07:45 AM	0	105	74	0	179	45	0	107	0	152	91	38	0	0	129	0	0	0	0	0	460
08:00 AM	0	90	108	0	198	34	0	92	0	126	106	39	0	0	145	0	0	0	0	0	469
08:15 AM	0	82	85	0	167	32	0	106	0	138	120	47	0	0	167	0	0	0	0	0	472
Total Volume	0	367	342	0	709	169	0	463	0	632	397	166	0	0	563	0	0	0	0	0	1904
% App. Total	0	51.8	48.2	0		26.7	0	73.3	0		70.5	29.5	0	0		0	0	0	0		
PHF	.000	.874	.792	.000	.895	.728	.000	.733	.000	.731	.827	.883	.000	.000	.843	.000	.000	.000	.000	.000	.946

# Traffic Data Service

Campbell, CA  
 (408) 377-2988  
 tdsbay@cs.com

File Name : 13AM FINAL  
 Site Code : 00000013  
 Start Date : 11/10/2010  
 Page No : 2

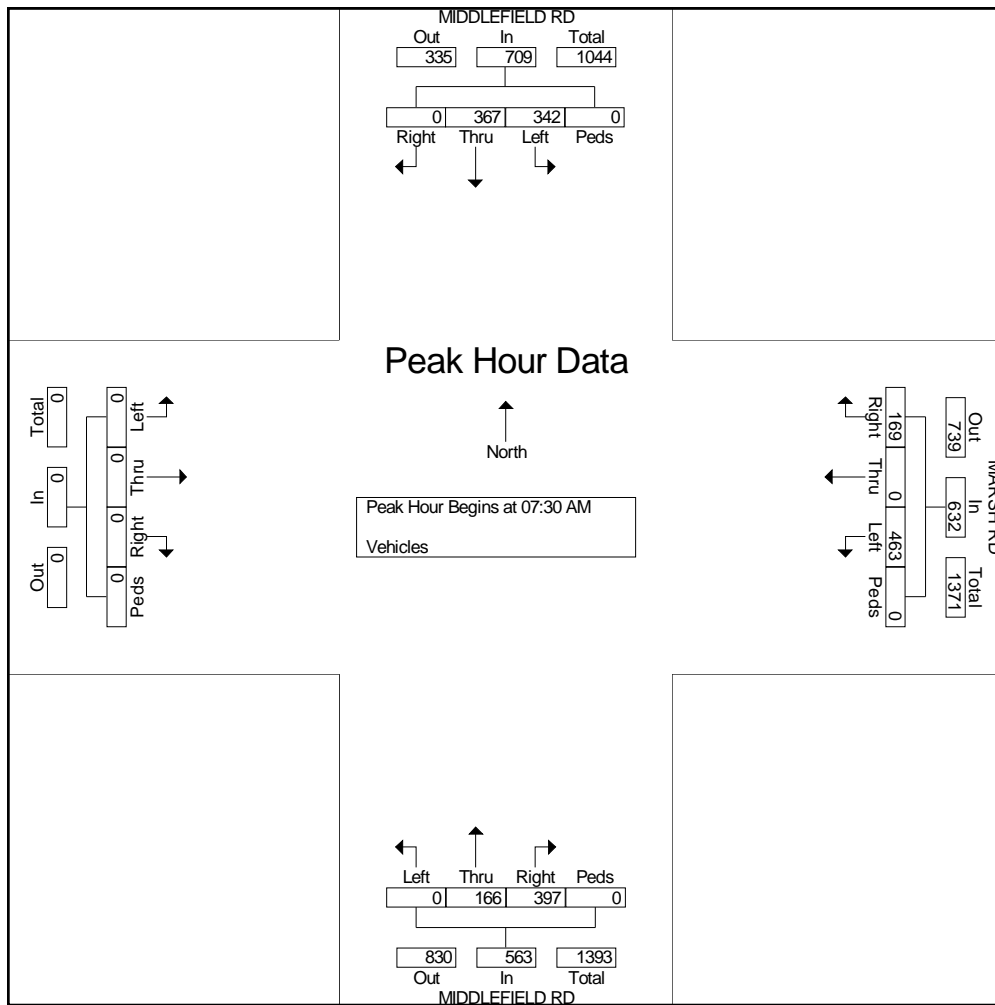

# Traffic Data Service

Campbell, CA  
(408) 377-2988  
tdsbay@cs.com

File Name : 13PM FINAL  
Site Code : 00000013  
Start Date : 11/10/2010  
Page No : 1

### Groups Printed- Vehicles

Start Time	MIDDLEFIELD RD Southbound					MARSH RD Westbound					MIDDLEFIELD RD Northbound					Eastbound					Int. Total
	Right	Thru	Left	Peds	App. Total	Right	Thru	Left	Peds	App. Total	Right	Thru	Left	Peds	App. Total	Right	Thru	Left	Peds	App. Total	
04:00 PM	0	51	98	0	149	76	0	101	0	177	128	98	0	0	226	0	0	0	0	0	552
04:15 PM	0	65	110	0	175	109	0	88	0	197	150	91	0	0	241	0	0	0	0	0	613
04:30 PM	0	49	116	0	165	88	0	108	0	196	156	97	0	0	253	0	0	0	0	0	614
04:45 PM	0	60	104	0	164	109	0	123	0	232	143	103	0	0	246	0	0	0	0	0	642
<b>Total</b>	<b>0</b>	<b>225</b>	<b>428</b>	<b>0</b>	<b>653</b>	<b>382</b>	<b>0</b>	<b>420</b>	<b>0</b>	<b>802</b>	<b>577</b>	<b>389</b>	<b>0</b>	<b>0</b>	<b>966</b>	<b>0</b>	<b>0</b>	<b>0</b>	<b>0</b>	<b>0</b>	<b>2421</b>
05:00 PM	0	60	103	0	163	113	0	139	0	252	144	111	0	0	255	0	0	0	0	0	670
05:15 PM	0	72	97	0	169	104	0	130	0	234	130	109	0	0	239	0	0	0	0	0	642
05:30 PM	0	77	104	0	181	121	0	123	0	244	131	103	0	0	234	0	0	0	0	0	659
05:45 PM	0	81	81	0	162	95	0	111	0	206	122	114	0	0	236	0	0	0	0	0	604
<b>Total</b>	<b>0</b>	<b>290</b>	<b>385</b>	<b>0</b>	<b>675</b>	<b>433</b>	<b>0</b>	<b>503</b>	<b>0</b>	<b>936</b>	<b>527</b>	<b>437</b>	<b>0</b>	<b>0</b>	<b>964</b>	<b>0</b>	<b>0</b>	<b>0</b>	<b>0</b>	<b>0</b>	<b>2575</b>
<b>Grand Total</b>	<b>0</b>	<b>515</b>	<b>813</b>	<b>0</b>	<b>1328</b>	<b>815</b>	<b>0</b>	<b>923</b>	<b>0</b>	<b>1738</b>	<b>1104</b>	<b>826</b>	<b>0</b>	<b>0</b>	<b>1930</b>	<b>0</b>	<b>0</b>	<b>0</b>	<b>0</b>	<b>0</b>	<b>4996</b>
Approch %	0	38.8	61.2	0		46.9	0	53.1	0		57.2	42.8	0	0		0	0	0	0		
Total %	0	10.3	16.3	0	26.6	16.3	0	18.5	0	34.8	22.1	16.5	0	0	38.6	0	0	0	0	0	

Start Time	MIDDLEFIELD RD Southbound					MARSH RD Westbound					MIDDLEFIELD RD Northbound					Eastbound					Int. Total
	Right	Thru	Left	Peds	App. Total	Right	Thru	Left	Peds	App. Total	Right	Thru	Left	Peds	App. Total	Right	Thru	Left	Peds	App. Total	
Peak Hour Analysis From 04:00 PM to 05:45 PM - Peak 1 of 1																					
Peak Hour for Entire Intersection Begins at 04:45 PM																					
04:45 PM	0	60	104	0	164	109	0	123	0	232	143	103	0	0	246	0	0	0	0	0	642
05:00 PM	0	60	103	0	163	113	0	139	0	252	144	111	0	0	255	0	0	0	0	0	670
05:15 PM	0	72	97	0	169	104	0	130	0	234	130	109	0	0	239	0	0	0	0	0	642
05:30 PM	0	77	104	0	181	121	0	123	0	244	131	103	0	0	234	0	0	0	0	0	659
Total Volume	0	269	408	0	677	447	0	515	0	962	548	426	0	0	974	0	0	0	0	0	2613
% App. Total	0	39.7	60.3	0		46.5	0	53.5	0		56.3	43.7	0	0		0	0	0	0		
PHF	.000	.873	.981	.000	.935	.924	.000	.926	.000	.954	.951	.959	.000	.000	.955	.000	.000	.000	.000	.000	.975

# Traffic Data Service

Campbell, CA  
 (408) 377-2988  
 tdsbay@cs.com

File Name : 13PM FINAL  
 Site Code : 00000013  
 Start Date : 11/10/2010  
 Page No : 2

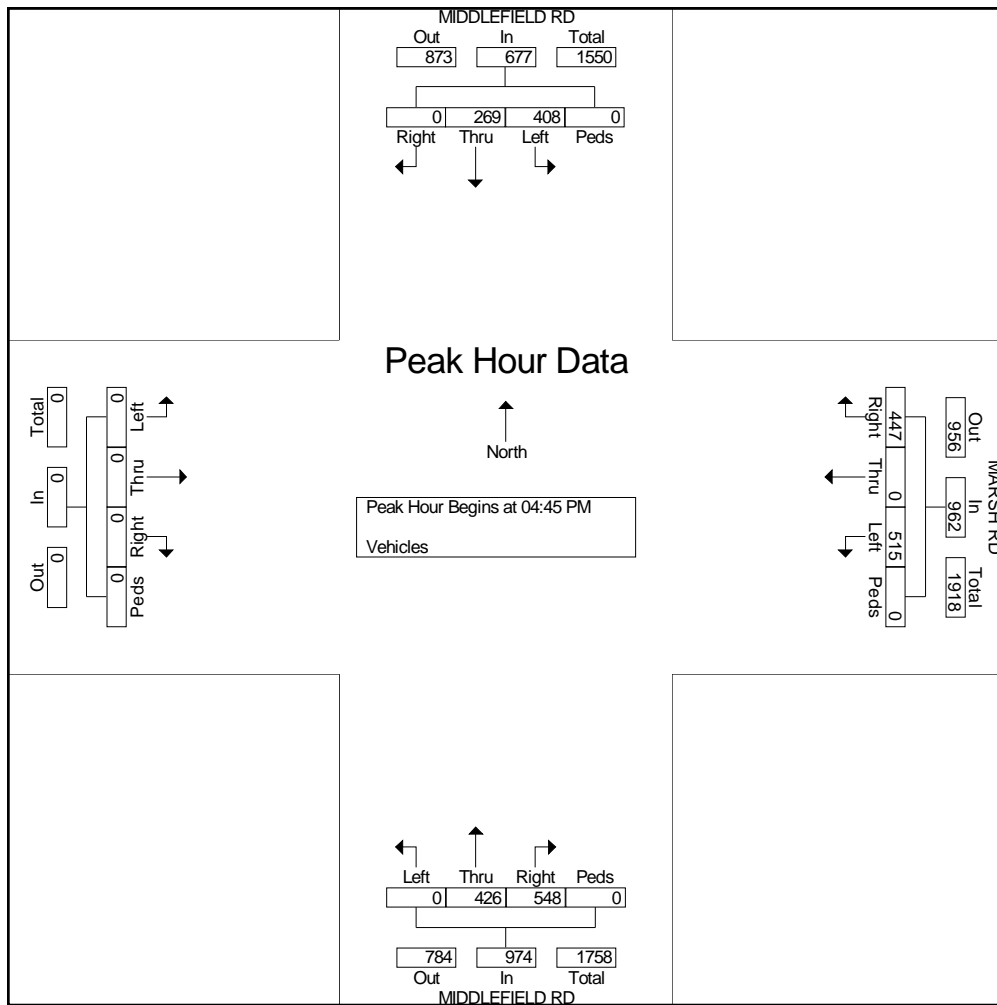

# Traffic Data Service

Campbell, CA  
(408) 377-2988  
tdsbay@cs.com

File Name : 14AM FINAL  
Site Code : 00000014  
Start Date : 11/9/2010  
Page No : 1

### Groups Printed- Vehicles

Start Time	BAYFRONT EXPY Southbound					NETWORK CIR Westbound					BAYFRONT EXPY Northbound					WILLOW RD Eastbound					Int. Total
	Right	Thru	Left	Peds	App. Total	Right	Thru	Left	Peds	App. Total	Right	Thru	Left	Peds	App. Total	Right	Thru	Left	Peds	App. Total	
07:00 AM	16	142	4	0	162	0	2	1	0	3	0	445	265	0	710	74	8	13	0	95	970
07:15 AM	14	179	2	0	195	0	3	0	0	3	1	525	271	0	797	85	9	16	0	110	1105
07:30 AM	26	159	3	0	188	1	1	1	0	3	2	538	290	0	830	106	8	28	0	142	1163
07:45 AM	27	157	5	0	189	3	0	2	0	5	1	571	232	0	804	94	9	22	0	125	1123
<b>Total</b>	<b>83</b>	<b>637</b>	<b>14</b>	<b>0</b>	<b>734</b>	<b>4</b>	<b>6</b>	<b>4</b>	<b>0</b>	<b>14</b>	<b>4</b>	<b>2079</b>	<b>1058</b>	<b>0</b>	<b>3141</b>	<b>359</b>	<b>34</b>	<b>79</b>	<b>0</b>	<b>472</b>	<b>4361</b>
08:00 AM	25	182	3	0	210	1	2	0	0	3	2	474	241	0	717	94	8	18	0	120	1050
08:15 AM	29	162	4	0	195	0	0	1	0	1	1	464	287	0	752	84	9	28	0	121	1069
08:30 AM	37	170	8	0	215	2	4	0	0	6	2	462	258	0	722	99	17	32	0	148	1091
08:45 AM	36	178	1	0	215	3	1	0	0	4	3	519	261	0	783	71	15	20	0	106	1108
<b>Total</b>	<b>127</b>	<b>692</b>	<b>16</b>	<b>0</b>	<b>835</b>	<b>6</b>	<b>7</b>	<b>1</b>	<b>0</b>	<b>14</b>	<b>8</b>	<b>1919</b>	<b>1047</b>	<b>0</b>	<b>2974</b>	<b>348</b>	<b>49</b>	<b>98</b>	<b>0</b>	<b>495</b>	<b>4318</b>
<b>Grand Total</b>	<b>210</b>	<b>1329</b>	<b>30</b>	<b>0</b>	<b>1569</b>	<b>10</b>	<b>13</b>	<b>5</b>	<b>0</b>	<b>28</b>	<b>12</b>	<b>3998</b>	<b>2105</b>	<b>0</b>	<b>6115</b>	<b>707</b>	<b>83</b>	<b>177</b>	<b>0</b>	<b>967</b>	<b>8679</b>
<b>Apprch %</b>	<b>13.4</b>	<b>84.7</b>	<b>1.9</b>	<b>0</b>		<b>35.7</b>	<b>46.4</b>	<b>17.9</b>	<b>0</b>		<b>0.2</b>	<b>65.4</b>	<b>34.4</b>	<b>0</b>		<b>73.1</b>	<b>8.6</b>	<b>18.3</b>	<b>0</b>		
<b>Total %</b>	<b>2.4</b>	<b>15.3</b>	<b>0.3</b>	<b>0</b>	<b>18.1</b>	<b>0.1</b>	<b>0.1</b>	<b>0.1</b>	<b>0</b>	<b>0.3</b>	<b>0.1</b>	<b>46.1</b>	<b>24.3</b>	<b>0</b>	<b>70.5</b>	<b>8.1</b>	<b>1</b>	<b>2</b>	<b>0</b>	<b>11.1</b>	

Start Time	BAYFRONT EXPY Southbound					NETWORK CIR Westbound					BAYFRONT EXPY Northbound					WILLOW RD Eastbound					Int. Total
	Right	Thru	Left	Peds	App. Total	Right	Thru	Left	Peds	App. Total	Right	Thru	Left	Peds	App. Total	Right	Thru	Left	Peds	App. Total	
Peak Hour Analysis From 07:00 AM to 08:45 AM - Peak 1 of 1																					
Peak Hour for Entire Intersection Begins at 07:15 AM																					
07:15 AM	14	179	2	0	195	0	3	0	0	3	1	525	271	0	797	85	9	16	0	110	1105
07:30 AM	26	159	3	0	188	1	1	1	0	3	2	538	290	0	830	106	8	28	0	142	1163
07:45 AM	27	157	5	0	189	3	0	2	0	5	1	571	232	0	804	94	9	22	0	125	1123
08:00 AM	25	182	3	0	210	1	2	0	0	3	2	474	241	0	717	94	8	18	0	120	1050
<b>Total Volume</b>	<b>92</b>	<b>677</b>	<b>13</b>	<b>0</b>	<b>782</b>	<b>5</b>	<b>6</b>	<b>3</b>	<b>0</b>	<b>14</b>	<b>6</b>	<b>2108</b>	<b>1034</b>	<b>0</b>	<b>3148</b>	<b>379</b>	<b>34</b>	<b>84</b>	<b>0</b>	<b>497</b>	<b>4441</b>
<b>% App. Total</b>																					
<b>PHF</b>	<b>.852</b>	<b>.930</b>	<b>.650</b>	<b>.000</b>	<b>.931</b>	<b>.417</b>	<b>.500</b>	<b>.375</b>	<b>.000</b>	<b>.700</b>	<b>.750</b>	<b>.923</b>	<b>.891</b>	<b>.000</b>	<b>.948</b>	<b>.894</b>	<b>.944</b>	<b>.750</b>	<b>.000</b>	<b>.875</b>	<b>.955</b>



# Traffic Data Service

Campbell, CA  
 (408) 377-2988  
 tdsbay@cs.com

File Name : 14AM FINAL  
 Site Code : 00000014  
 Start Date : 11/9/2010  
 Page No : 2

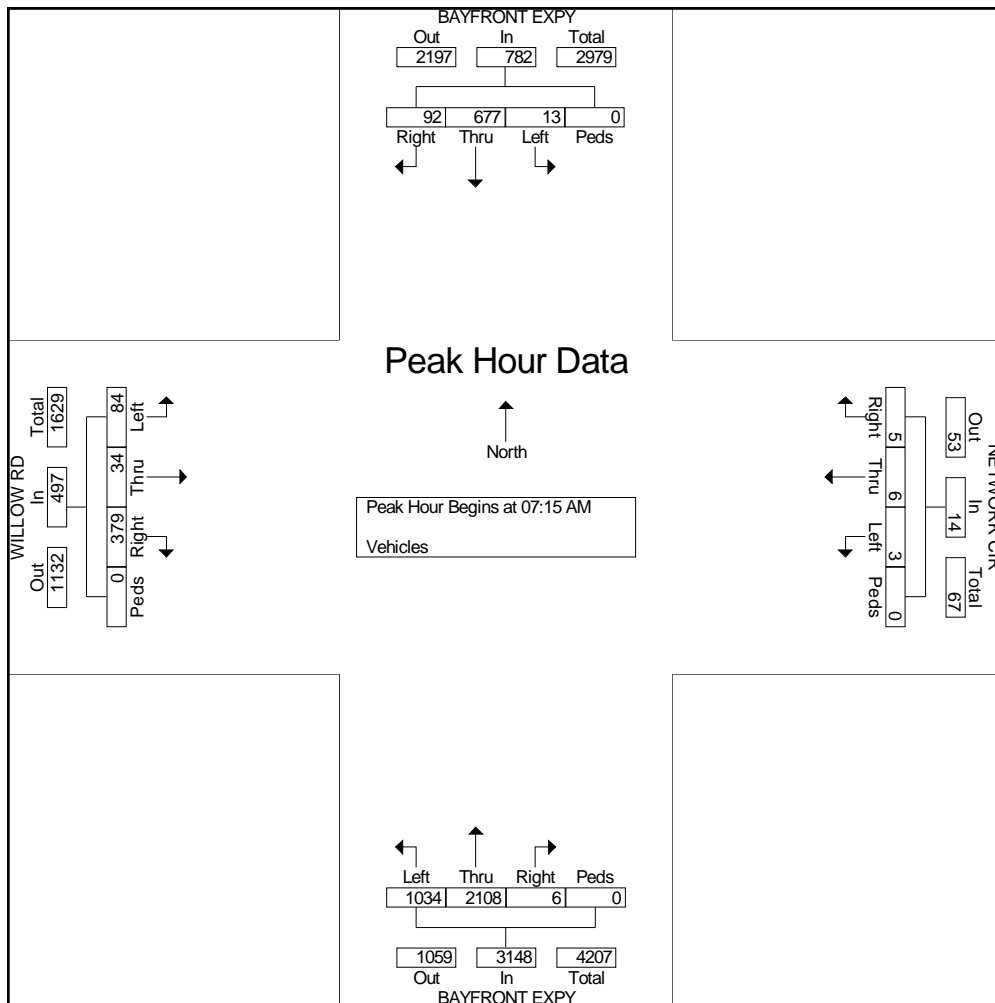

# All Traffic Data

(916) 771-8700

CITY OF MENLOW PARK

File Name : 11-7184-002 WILLOW-BAYFRONT EXPY

Site Code : 00000000

Start Date : 5/3/2011

Page No : 1

## Groups Printed- Unshifted

Start Time	WILLOW RD. Southbound				BAYFRONT EXPY. Westbound				WILLOW RD. Northbound				BAYFRONT EXPY. Eastbound				Int. Total
	Left	Thru	Right	App. Total	Left	Thru	Right	App. Total	Left	Thru	Right	App. Total	Left	Thru	Right	App. Total	
08:30	0	3	1	4	289	575	3	867	30	8	81	119	2	159	41	202	1192
08:45	2	1	0	3	250	543	8	801	27	7	82	116	5	184	49	238	1158
Total	2	4	1	7	539	1118	11	1668	57	15	163	235	7	343	90	440	2350
09:00	1	2	0	3	233	466	0	699	21	12	90	123	2	177	56	235	1060
09:15	1	2	0	3	230	406	4	640	25	13	92	130	2	134	44	180	953
09:30	0	7	1	8	253	379	4	636	37	19	102	158	4	136	30	170	972
09:45	1	3	2	6	207	331	0	538	11	16	72	99	3	126	29	158	801
Total	3	14	3	20	923	1582	8	2513	94	60	356	510	11	573	159	743	3786
10:00	0	1	1	2	165	214	3	382	14	7	65	86	3	114	27	144	614
10:15	0	3	3	6	155	226	0	381	12	9	81	102	5	113	27	145	634
Grand Total	5	22	8	35	1782	3140	22	4944	177	91	665	933	26	1143	303	1472	7384
Apprch %	14.3	62.9	22.9		36	63.5	0.4		19	9.8	71.3		1.8	77.6	20.6		
Total %	0.1	0.3	0.1	0.5	24.1	42.5	0.3	67	2.4	1.2	9	12.6	0.4	15.5	4.1	19.9	

Start Time	WILLOW RD. Southbound				BAYFRONT EXPY. Westbound				WILLOW RD. Northbound				BAYFRONT EXPY. Eastbound				Int. Total
	Left	Thru	Right	App. Total	Left	Thru	Right	App. Total	Left	Thru	Right	App. Total	Left	Thru	Right	App. Total	
08:30	0	<b>3</b>	<b>1</b>	<b>4</b>	<b>289</b>	<b>575</b>	3	<b>867</b>	<b>30</b>	8	81	119	2	159	41	202	<b>1192</b>
08:45	<b>2</b>	1	0	3	250	543	<b>8</b>	801	27	7	82	116	<b>5</b>	<b>184</b>	49	<b>238</b>	1158
09:00	1	2	0	3	233	466	0	699	21	12	90	123	2	177	<b>56</b>	235	1060
09:15	1	2	0	3	230	406	4	640	25	<b>13</b>	<b>92</b>	<b>130</b>	2	134	44	180	953
Total Volume	4	8	1	13	1002	1990	15	3007	103	40	345	488	11	654	190	855	4363
% App. Total	30.8	61.5	7.7		33.3	66.2	0.5		21.1	8.2	70.7		1.3	76.5	22.2		
PHF	.500	.667	.250	.813	.867	.865	.469	.867	.858	.769	.938	.938	.550	.889	.848	.898	.915

Peak Hour Analysis From 08:30 to 10:15 - Peak 1 of 1

Peak Hour for Entire Intersection Begins at 08:30

# All Traffic Data

(916) 771-8700

CITY OF MENLOW PARK

File Name : 11-7184-002 WILLOW-BAYFRONT EXPY

Site Code : 00000000

Start Date : 5/3/2011

Page No : 2

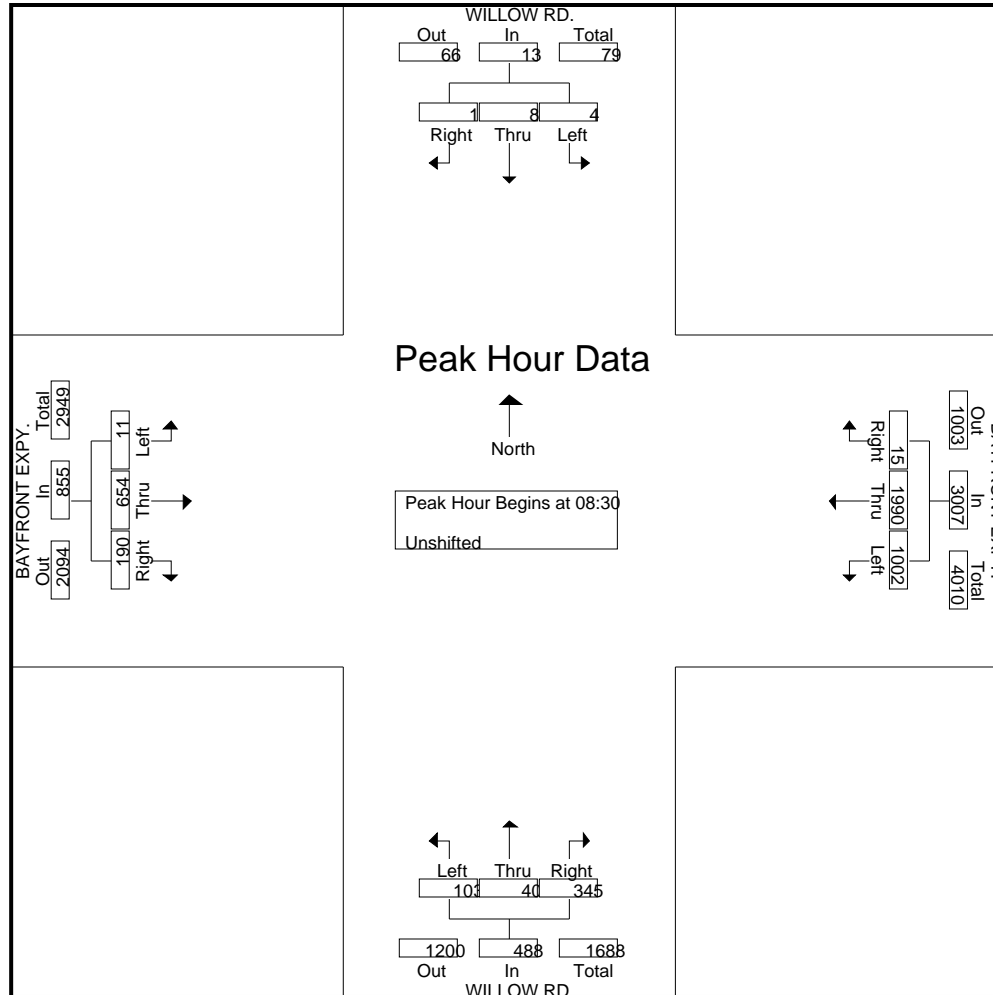

# Traffic Data Service

Campbell, CA  
(408) 377-2988  
tdsbay@cs.com

File Name : 14PM FINAL  
Site Code : 00000014  
Start Date : 11/9/2010  
Page No : 1

### Groups Printed- Vehicles

Start Time	BAYFRONT EXPY Southbound					NETWORK CIR Westbound					BAYFRONT EXPY Northbound					WILLOW RD Eastbound					Int. Total
	Right	Thru	Left	Peds	App. Total	Right	Thru	Left	Peds	App. Total	Right	Thru	Left	Peds	App. Total	Right	Thru	Left	Peds	App. Total	
04:00 PM	17	449	4	0	470	7	24	8	0	39	0	148	62	0	210	292	8	18	0	318	1037
04:15 PM	26	455	1	0	482	4	26	9	0	39	0	154	93	0	247	283	4	11	0	298	1066
04:30 PM	24	503	0	0	527	2	26	11	0	39	0	169	74	0	243	303	1	12	0	316	1125
04:45 PM	23	451	0	0	474	5	27	11	0	43	2	159	92	0	253	326	1	7	0	334	1104
<b>Total</b>	<b>90</b>	<b>1858</b>	<b>5</b>	<b>0</b>	<b>1953</b>	<b>18</b>	<b>103</b>	<b>39</b>	<b>0</b>	<b>160</b>	<b>2</b>	<b>630</b>	<b>321</b>	<b>0</b>	<b>953</b>	<b>1204</b>	<b>14</b>	<b>48</b>	<b>0</b>	<b>1266</b>	<b>4332</b>
05:00 PM	27	557	0	0	584	5	29	12	0	46	1	163	83	0	247	317	3	8	0	328	1205
05:15 PM	25	602	0	0	627	2	30	15	0	47	0	180	83	0	263	345	3	14	0	362	1299
05:30 PM	29	547	0	0	576	0	25	4	0	29	0	159	115	0	274	383	2	7	0	392	1271
05:45 PM	27	493	0	0	520	1	21	13	0	35	0	162	81	0	243	379	5	7	0	391	1189
<b>Total</b>	<b>108</b>	<b>2199</b>	<b>0</b>	<b>0</b>	<b>2307</b>	<b>8</b>	<b>105</b>	<b>44</b>	<b>0</b>	<b>157</b>	<b>1</b>	<b>664</b>	<b>362</b>	<b>0</b>	<b>1027</b>	<b>1424</b>	<b>13</b>	<b>36</b>	<b>0</b>	<b>1473</b>	<b>4964</b>
Grand Total	198	4057	5	0	4260	26	208	83	0	317	3	1294	683	0	1980	2628	27	84	0	2739	9296
Apprch %	4.6	95.2	0.1	0		8.2	65.6	26.2	0		0.2	65.4	34.5	0		95.9	1	3.1	0		
Total %	2.1	43.6	0.1	0	45.8	0.3	2.2	0.9	0	3.4	0	13.9	7.3	0	21.3	28.3	0.3	0.9	0	29.5	

Start Time	BAYFRONT EXPY Southbound					NETWORK CIR Westbound					BAYFRONT EXPY Northbound					WILLOW RD Eastbound					Int. Total
	Right	Thru	Left	Peds	App. Total	Right	Thru	Left	Peds	App. Total	Right	Thru	Left	Peds	App. Total	Right	Thru	Left	Peds	App. Total	
Peak Hour Analysis From 04:00 PM to 05:45 PM - Peak 1 of 1																					
Peak Hour for Entire Intersection Begins at 05:00 PM																					
05:00 PM	27	557	0	0	584	5	29	12	0	46	1	163	83	0	247	317	3	8	0	328	1205
05:15 PM	25	602	0	0	627	2	30	15	0	47	0	180	83	0	263	345	3	14	0	362	1299
05:30 PM	29	547	0	0	576	0	25	4	0	29	0	159	115	0	274	383	2	7	0	392	1271
05:45 PM	27	493	0	0	520	1	21	13	0	35	0	162	81	0	243	379	5	7	0	391	1189
Total Volume	108	2199	0	0	2307	8	105	44	0	157	1	664	362	0	1027	1424	13	36	0	1473	4964
% App. Total																					
PHF	.931	.913	.000	.000	.920	.400	.875	.733	.000	.835	.250	.922	.787	.000	.937	.930	.650	.643	.000	.939	.955

# Traffic Data Service

Campbell, CA  
 (408) 377-2988  
 tdsbay@cs.com

File Name : 14PM FINAL  
 Site Code : 00000014  
 Start Date : 11/9/2010  
 Page No : 2

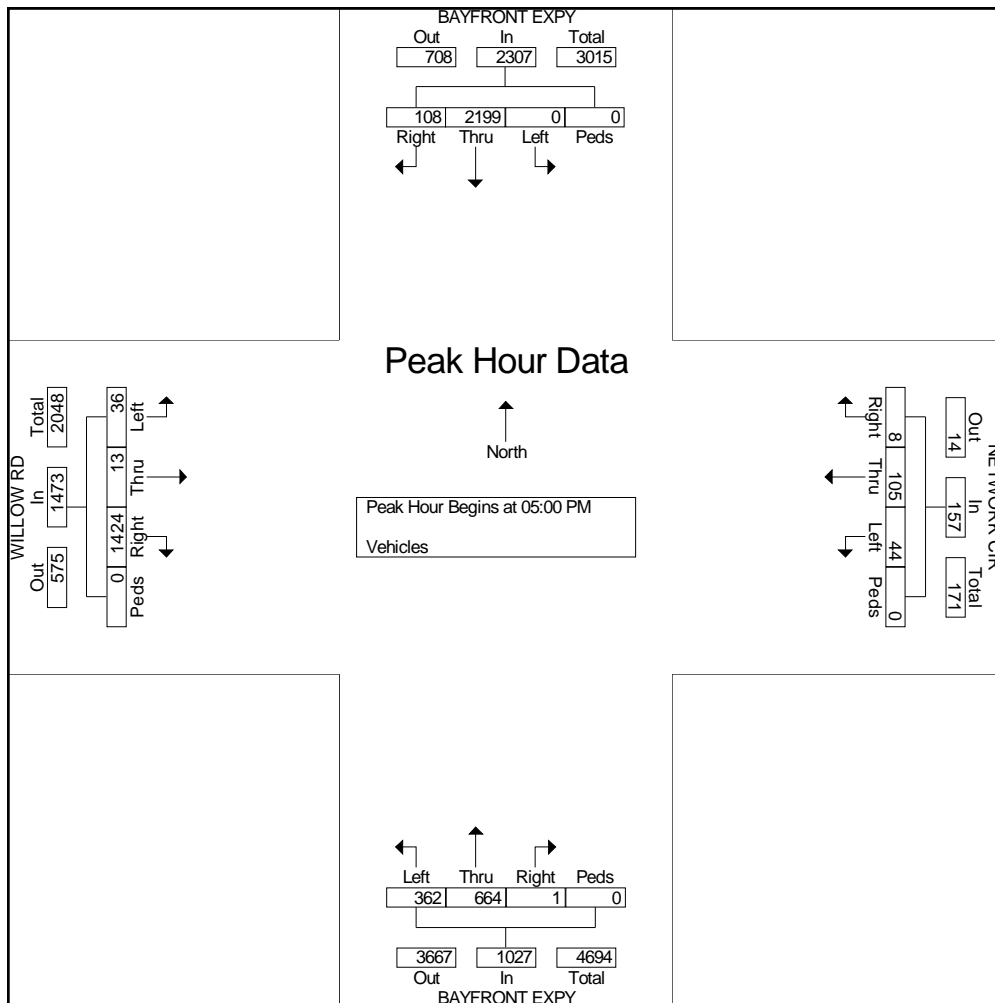

# Traffic Data Service

Campbell, CA  
(408) 377-2988  
tdsbay@cs.com

File Name : 15AM FINAL  
Site Code : 00000015  
Start Date : 11/9/2010  
Page No : 1

### Groups Printed- Vehicles

Start Time	HAMILTON AVE Southbound					WILLOW RD Westbound					HAMILTON AVE Northbound					WILLOW RD Eastbound					Int. Total
	Right	Thru	Left	Peds	App. Total	Right	Thru	Left	Peds	App. Total	Right	Thru	Left	Peds	App. Total	Right	Thru	Left	Peds	App. Total	
07:00 AM	17	4	6	0	27	12	263	5	0	280	3	2	2	0	7	16	79	22	0	117	431
07:15 AM	19	0	15	0	34	14	264	16	0	294	0	0	1	0	1	14	109	23	0	146	475
07:30 AM	16	4	31	0	51	15	294	14	0	323	5	4	6	0	15	12	120	20	0	152	541
07:45 AM	12	4	21	0	37	14	191	23	0	228	2	1	2	0	5	9	106	22	0	137	407
<b>Total</b>	<b>64</b>	<b>12</b>	<b>73</b>	<b>0</b>	<b>149</b>	<b>55</b>	<b>1012</b>	<b>58</b>	<b>0</b>	<b>1125</b>	<b>10</b>	<b>7</b>	<b>11</b>	<b>0</b>	<b>28</b>	<b>51</b>	<b>414</b>	<b>87</b>	<b>0</b>	<b>552</b>	<b>1854</b>
08:00 AM	10	5	19	0	34	25	244	22	0	291	5	1	3	0	9	11	97	28	0	136	470
08:15 AM	17	1	17	0	35	8	243	16	0	267	9	6	8	0	23	11	104	25	0	140	465
08:30 AM	28	5	24	0	57	10	265	14	0	289	5	4	5	0	14	17	132	31	0	180	540
08:45 AM	17	8	11	0	36	13	285	22	0	320	7	2	2	0	11	13	82	31	0	126	493
<b>Total</b>	<b>72</b>	<b>19</b>	<b>71</b>	<b>0</b>	<b>162</b>	<b>56</b>	<b>1037</b>	<b>74</b>	<b>0</b>	<b>1167</b>	<b>26</b>	<b>13</b>	<b>18</b>	<b>0</b>	<b>57</b>	<b>52</b>	<b>415</b>	<b>115</b>	<b>0</b>	<b>582</b>	<b>1968</b>
Grand Total	136	31	144	0	311	111	2049	132	0	2292	36	20	29	0	85	103	829	202	0	1134	3822
Apprch %	43.7	10	46.3	0		4.8	89.4	5.8	0		42.4	23.5	34.1	0		9.1	73.1	17.8	0		
Total %	3.6	0.8	3.8	0	8.1	2.9	53.6	3.5	0	60	0.9	0.5	0.8	0	2.2	2.7	21.7	5.3	0	29.7	

Start Time	HAMILTON AVE Southbound					WILLOW RD Westbound					HAMILTON AVE Northbound					WILLOW RD Eastbound					Int. Total
	Right	Thru	Left	Peds	App. Total	Right	Thru	Left	Peds	App. Total	Right	Thru	Left	Peds	App. Total	Right	Thru	Left	Peds	App. Total	
Peak Hour Analysis From 07:00 AM to 08:45 AM - Peak 1 of 1																					
Peak Hour for Entire Intersection Begins at 08:00 AM																					
08:00 AM	10	5	19	0	34	25	244	22	0	291	5	1	3	0	9	11	97	28	0	136	470
08:15 AM	17	1	17	0	35	8	243	16	0	267	9	6	8	0	23	11	104	25	0	140	465
08:30 AM	28	5	24	0	57	10	265	14	0	289	5	4	5	0	14	17	132	31	0	180	540
08:45 AM	17	8	11	0	36	13	285	22	0	320	7	2	2	0	11	13	82	31	0	126	493
Total Volume	72	19	71	0	162	56	1037	74	0	1167	26	13	18	0	57	52	415	115	0	582	1968
% App. Total																					
PHF	.643	.594	.740	.000	.711	.560	.910	.841	.000	.912	.722	.542	.563	.000	.620	.765	.786	.927	.000	.808	.911

# Traffic Data Service

Campbell, CA  
 (408) 377-2988  
 tdsbay@cs.com

File Name : 15AM FINAL  
 Site Code : 00000015  
 Start Date : 11/9/2010  
 Page No : 2

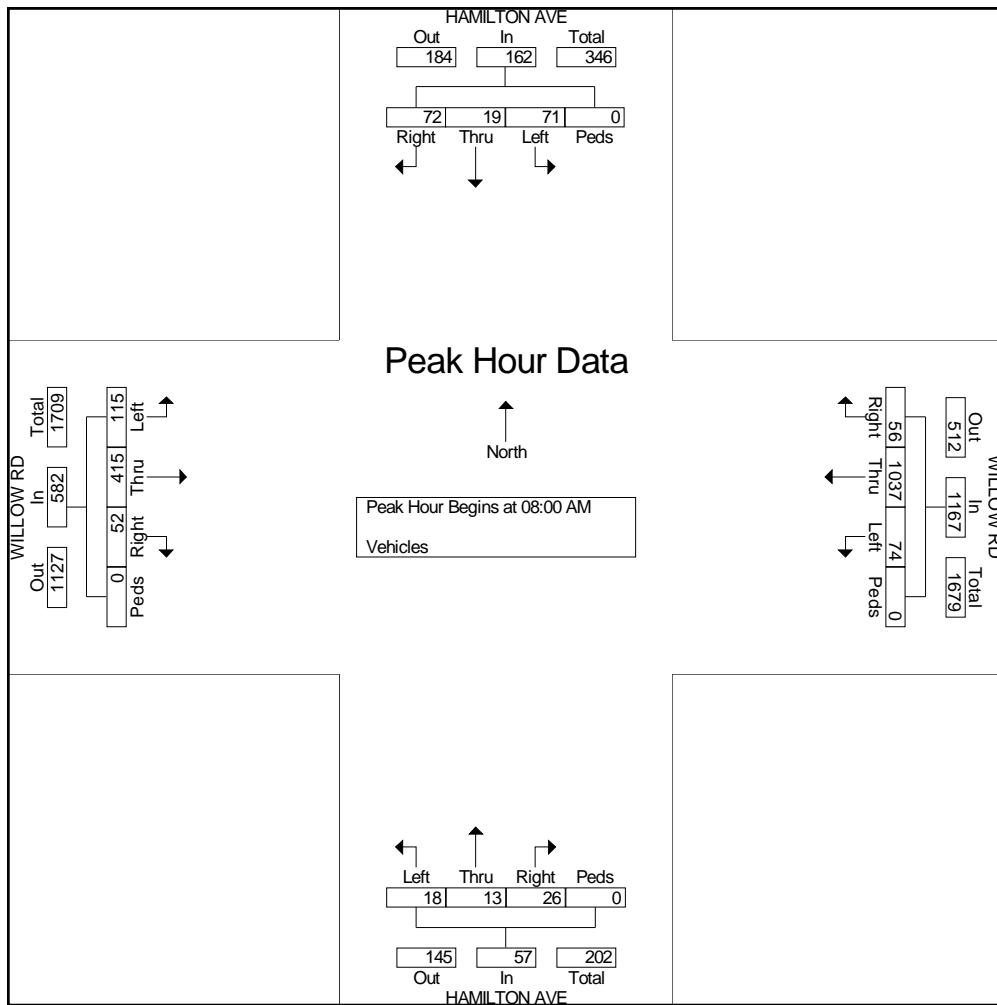

# Traffic Data Service

Campbell, CA  
(408) 377-2988  
tdsbay@cs.com

File Name : 15PM FINAL  
Site Code : 00000015  
Start Date : 11/9/2010  
Page No : 1

### Groups Printed- Vehicles

Start Time	HAMILTON AVE Southbound					WILLOW RD Westbound					HAMILTON AVE Northbound					WILLOW RD Eastbound					Int. Total
	Right	Thru	Left	Peds	App. Total	Right	Thru	Left	Peds	App. Total	Right	Thru	Left	Peds	App. Total	Right	Thru	Left	Peds	App. Total	
04:00 PM	17	1	13	0	31	9	100	3	0	112	12	3	17	0	32	3	253	22	0	278	453
04:15 PM	23	3	12	0	38	19	118	5	0	142	11	4	19	0	34	2	270	23	0	295	509
04:30 PM	16	0	15	0	31	10	123	7	0	140	16	4	16	0	36	2	284	32	0	318	525
04:45 PM	21	2	16	0	39	15	123	1	0	139	9	0	20	0	29	3	257	31	0	291	498
<b>Total</b>	<b>77</b>	<b>6</b>	<b>56</b>	<b>0</b>	<b>139</b>	<b>53</b>	<b>464</b>	<b>16</b>	<b>0</b>	<b>533</b>	<b>48</b>	<b>11</b>	<b>72</b>	<b>0</b>	<b>131</b>	<b>10</b>	<b>1064</b>	<b>108</b>	<b>0</b>	<b>1182</b>	<b>1985</b>
05:00 PM	14	0	18	0	32	14	140	6	0	160	8	1	32	0	41	1	311	26	0	338	571
05:15 PM	22	2	16	0	40	15	137	8	0	160	17	2	38	0	57	1	341	38	0	380	637
05:30 PM	18	2	22	0	42	18	146	3	0	167	9	2	27	0	38	1	338	34	0	373	620
05:45 PM	19	1	17	0	37	20	130	3	0	153	15	1	32	0	48	2	361	32	0	395	633
<b>Total</b>	<b>73</b>	<b>5</b>	<b>73</b>	<b>0</b>	<b>151</b>	<b>67</b>	<b>553</b>	<b>20</b>	<b>0</b>	<b>640</b>	<b>49</b>	<b>6</b>	<b>129</b>	<b>0</b>	<b>184</b>	<b>5</b>	<b>1351</b>	<b>130</b>	<b>0</b>	<b>1486</b>	<b>2461</b>
Grand Total	150	11	129	0	290	120	1017	36	0	1173	97	17	201	0	315	15	2415	238	0	2668	4446
Apprch %	51.7	3.8	44.5	0		10.2	86.7	3.1	0		30.8	5.4	63.8	0		0.6	90.5	8.9	0		
Total %	3.4	0.2	2.9	0	6.5	2.7	22.9	0.8	0	26.4	2.2	0.4	4.5	0	7.1	0.3	54.3	5.4	0	60	

Start Time	HAMILTON AVE Southbound					WILLOW RD Westbound					HAMILTON AVE Northbound					WILLOW RD Eastbound					Int. Total
	Right	Thru	Left	Peds	App. Total	Right	Thru	Left	Peds	App. Total	Right	Thru	Left	Peds	App. Total	Right	Thru	Left	Peds	App. Total	
Peak Hour Analysis From 04:00 PM to 05:45 PM - Peak 1 of 1																					
Peak Hour for Entire Intersection Begins at 05:00 PM																					
05:00 PM	14	0	18	0	32	14	140	6	0	160	8	1	32	0	41	1	311	26	0	338	571
05:15 PM	22	2	16	0	40	15	137	8	0	160	17	2	38	0	57	1	341	38	0	380	637
05:30 PM	18	2	22	0	42	18	146	3	0	167	9	2	27	0	38	1	338	34	0	373	620
05:45 PM	19	1	17	0	37	20	130	3	0	153	15	1	32	0	48	2	361	32	0	395	633
Total Volume	73	5	73	0	151	67	553	20	0	640	49	6	129	0	184	5	1351	130	0	1486	2461
% App. Total																					
PHF	.830	.625	.830	.000	.899	.838	.947	.625	.000	.958	.721	.750	.849	.000	.807	.625	.936	.855	.000	.941	.966



# Traffic Data Service

Campbell, CA  
 (408) 377-2988  
 tdsbay@cs.com

File Name : 15PM FINAL  
 Site Code : 00000015  
 Start Date : 11/9/2010  
 Page No : 2

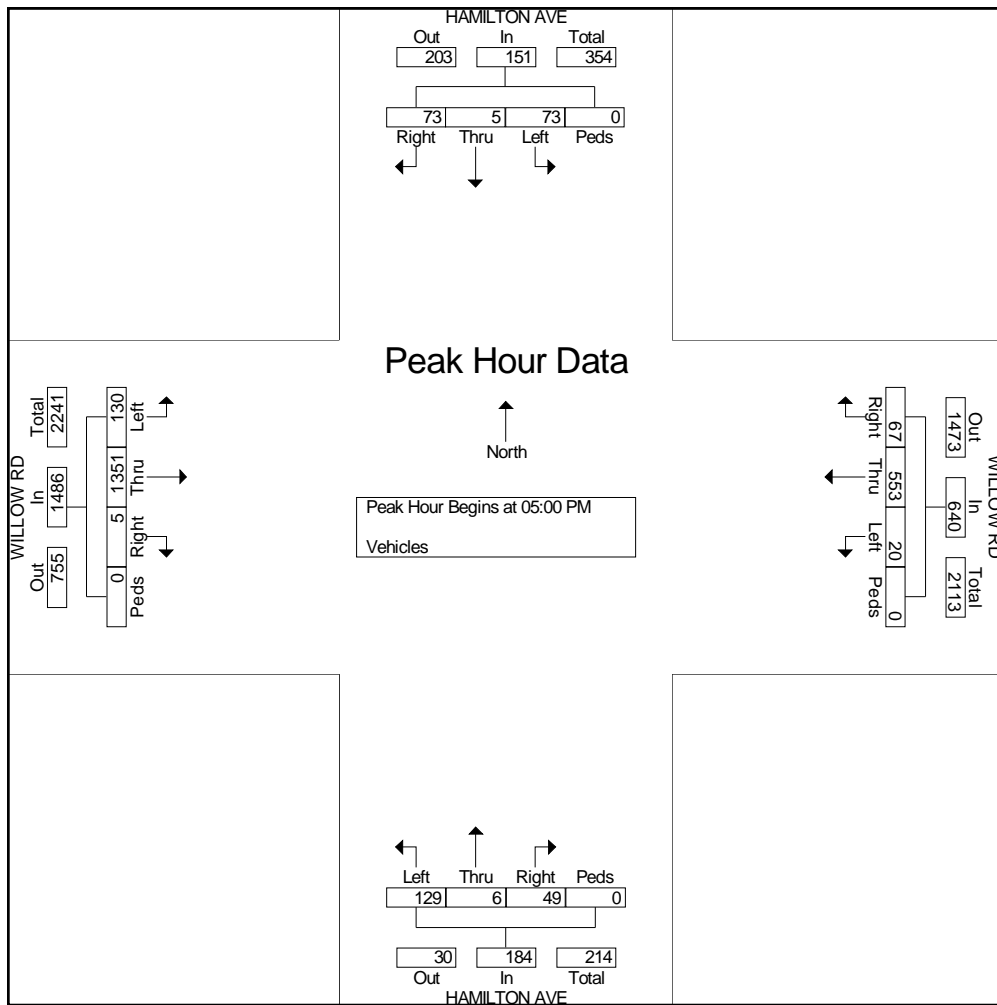

# Traffic Data Service

Campbell, CA  
(408) 377-2988  
tdsbay@cs.com

File Name : 16AM FINAL  
Site Code : 00000016  
Start Date : 11/10/2010  
Page No : 1

## Groups Printed- Vehicles

Start Time	IVY DR Southbound					WILLOW RD Westbound					Northbound					WILLOW RD Eastbound					Int. Total
	Right	Thru	Left	Peds	App. Total	Right	Thru	Left	Peds	App. Total	Right	Thru	Left	Peds	App. Total	Right	Thru	Left	Peds	App. Total	
07:00 AM	24	0	1	0	25	0	294	0	0	294	0	0	0	0	0	0	144	13	0	157	476
07:15 AM	40	0	1	0	41	2	284	0	0	286	0	0	0	0	0	0	156	19	0	175	502
07:30 AM	61	0	0	0	61	3	287	0	0	290	0	0	0	0	0	0	155	14	0	169	520
07:45 AM	40	0	0	0	40	2	227	0	0	229	0	0	0	0	0	0	167	21	0	188	457
<b>Total</b>	<b>165</b>	<b>0</b>	<b>2</b>	<b>0</b>	<b>167</b>	<b>7</b>	<b>1092</b>	<b>0</b>	<b>0</b>	<b>1099</b>	<b>0</b>	<b>0</b>	<b>0</b>	<b>0</b>	<b>0</b>	<b>0</b>	<b>622</b>	<b>67</b>	<b>0</b>	<b>689</b>	<b>1955</b>
08:00 AM	45	0	0	0	45	7	223	0	0	230	0	0	0	0	0	0	174	28	0	202	477
08:15 AM	35	0	2	0	37	0	235	0	0	235	0	0	0	0	0	0	150	24	0	174	446
08:30 AM	20	0	4	0	24	2	315	0	0	317	0	0	0	0	0	0	172	19	0	191	532
08:45 AM	18	0	3	0	21	9	288	0	0	297	0	0	0	0	0	0	142	14	0	156	474
<b>Total</b>	<b>118</b>	<b>0</b>	<b>9</b>	<b>0</b>	<b>127</b>	<b>18</b>	<b>1061</b>	<b>0</b>	<b>0</b>	<b>1079</b>	<b>0</b>	<b>0</b>	<b>0</b>	<b>0</b>	<b>0</b>	<b>0</b>	<b>638</b>	<b>85</b>	<b>0</b>	<b>723</b>	<b>1929</b>
Grand Total	283	0	11	0	294	25	2153	0	0	2178	0	0	0	0	0	0	1260	152	0	1412	3884
Apprch %	96.3	0	3.7	0		1.1	98.9	0	0		0	0	0	0		0	89.2	10.8	0		
Total %	7.3	0	0.3	0	7.6	0.6	55.4	0	0	56.1	0	0	0	0		0	32.4	3.9	0	36.4	

Start Time	IVY DR Southbound					WILLOW RD Westbound					Northbound					WILLOW RD Eastbound					Int. Total
	Right	Thru	Left	Peds	App. Total	Right	Thru	Left	Peds	App. Total	Right	Thru	Left	Peds	App. Total	Right	Thru	Left	Peds	App. Total	
Peak Hour Analysis From 07:00 AM to 08:45 AM - Peak 1 of 1																					
Peak Hour for Entire Intersection Begins at 07:15 AM																					
07:15 AM	40	0	1	0	41	2	284	0	0	286	0	0	0	0	0	0	156	19	0	175	502
07:30 AM	61	0	0	0	61	3	287	0	0	290	0	0	0	0	0	0	155	14	0	169	520
07:45 AM	40	0	0	0	40	2	227	0	0	229	0	0	0	0	0	0	167	21	0	188	457
08:00 AM	45	0	0	0	45	7	223	0	0	230	0	0	0	0	0	0	174	28	0	202	477
Total Volume	186	0	1	0	187	14	1021	0	0	1035	0	0	0	0	0	0	652	82	0	734	1956
% App. Total																					
PHF	.762	.000	.250	.000	.766	.500	.889	.000	.000	.892	.000	.000	.000	.000	.000	.000	.937	.732	.000	.908	.940

# Traffic Data Service

Campbell, CA  
 (408) 377-2988  
 tdsbay@cs.com

File Name : 16AM FINAL  
 Site Code : 00000016  
 Start Date : 11/10/2010  
 Page No : 2

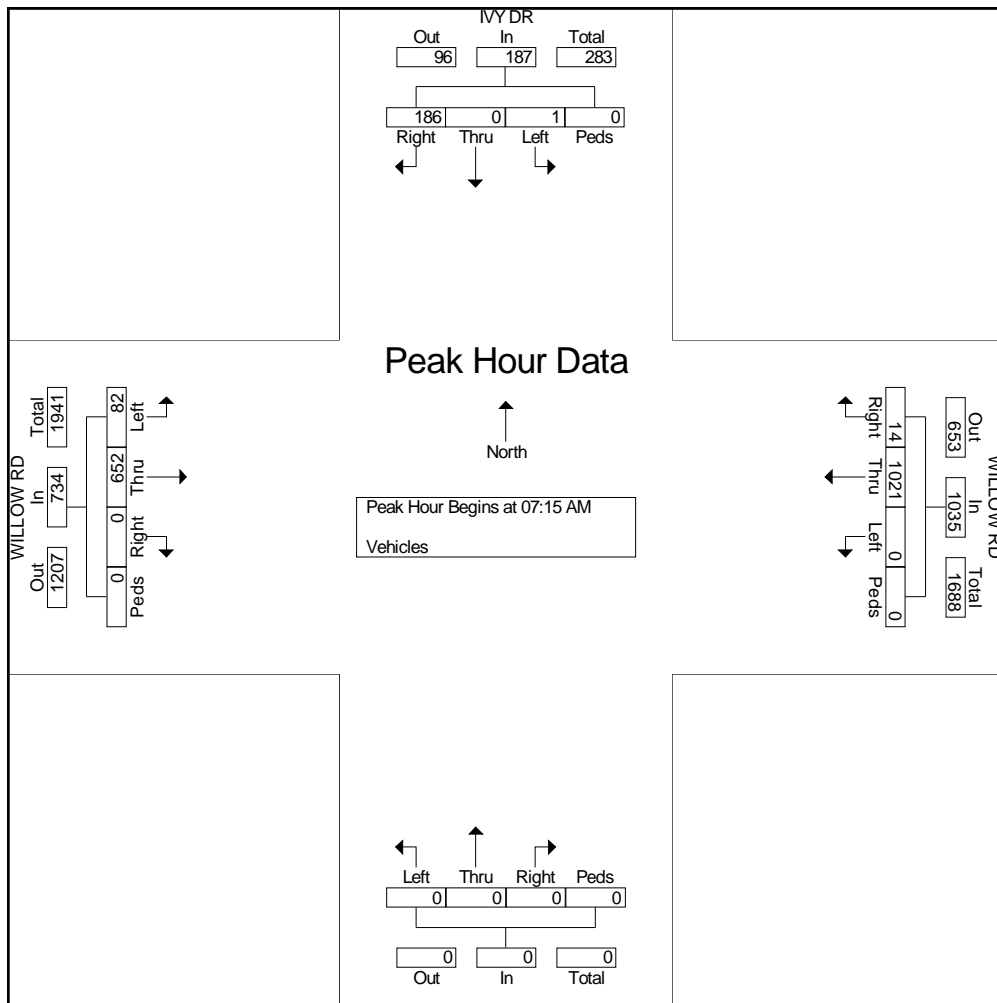

# Traffic Data Service

Campbell, CA  
(408) 377-2988  
tdsbay@cs.com

File Name : 16PM FINAL  
Site Code : 00000016  
Start Date : 11/10/2010  
Page No : 1

### Groups Printed- Vehicles

Start Time	IVY DR Southbound					WILLOW RD Westbound					Northbound					WILLOW RD Eastbound					Int. Total
	Right	Thru	Left	Peds	App. Total	Right	Thru	Left	Peds	App. Total	Right	Thru	Left	Peds	App. Total	Right	Thru	Left	Peds	App. Total	
04:00 PM	27	0	1	0	28	2	167	0	0	169	0	0	0	0	0	0	319	42	0	361	558
04:15 PM	26	0	1	0	27	6	144	0	0	150	0	0	0	0	0	0	310	27	0	337	514
04:30 PM	34	0	1	0	35	6	159	0	0	165	0	0	0	0	0	0	271	23	0	294	494
04:45 PM	25	0	3	0	28	6	178	0	0	184	0	0	0	0	0	0	300	26	0	326	538
<b>Total</b>	<b>112</b>	<b>0</b>	<b>6</b>	<b>0</b>	<b>118</b>	<b>20</b>	<b>648</b>	<b>0</b>	<b>0</b>	<b>668</b>	<b>0</b>	<b>0</b>	<b>0</b>	<b>0</b>	<b>0</b>	<b>0</b>	<b>1200</b>	<b>118</b>	<b>0</b>	<b>1318</b>	<b>2104</b>
05:00 PM	26	0	2	0	28	3	203	0	0	206	0	0	0	0	0	0	356	26	0	382	616
05:15 PM	30	0	1	0	31	6	216	0	0	222	0	0	0	0	0	0	377	20	0	397	650
05:30 PM	37	0	6	0	43	5	170	0	0	175	0	0	0	0	0	0	354	32	0	386	604
05:45 PM	29	0	1	0	30	8	211	0	0	219	0	0	0	0	0	0	370	20	0	390	639
<b>Total</b>	<b>122</b>	<b>0</b>	<b>10</b>	<b>0</b>	<b>132</b>	<b>22</b>	<b>800</b>	<b>0</b>	<b>0</b>	<b>822</b>	<b>0</b>	<b>0</b>	<b>0</b>	<b>0</b>	<b>0</b>	<b>0</b>	<b>1457</b>	<b>98</b>	<b>0</b>	<b>1555</b>	<b>2509</b>
Grand Total	234	0	16	0	250	42	1448	0	0	1490	0	0	0	0	0	0	2657	216	0	2873	4613
Apprch %	93.6	0	6.4	0		2.8	97.2	0	0		0	0	0	0		0	92.5	7.5	0		
Total %	5.1	0	0.3	0	5.4	0.9	31.4	0	0	32.3	0	0	0	0	0	0	57.6	4.7	0	62.3	

Start Time	IVY DR Southbound					WILLOW RD Westbound					Northbound					WILLOW RD Eastbound					Int. Total
	Right	Thru	Left	Peds	App. Total	Right	Thru	Left	Peds	App. Total	Right	Thru	Left	Peds	App. Total	Right	Thru	Left	Peds	App. Total	
Peak Hour Analysis From 04:00 PM to 05:45 PM - Peak 1 of 1																					
Peak Hour for Entire Intersection Begins at 05:00 PM																					
05:00 PM	26	0	2	0	28	3	203	0	0	206	0	0	0	0	0	0	356	26	0	382	616
05:15 PM	30	0	1	0	31	6	216	0	0	222	0	0	0	0	0	0	377	20	0	397	650
05:30 PM	37	0	6	0	43	5	170	0	0	175	0	0	0	0	0	0	354	32	0	386	604
05:45 PM	29	0	1	0	30	8	211	0	0	219	0	0	0	0	0	0	370	20	0	390	639
Total Volume	122	0	10	0	132	22	800	0	0	822	0	0	0	0	0	0	1457	98	0	1555	2509
% App. Total																					
PHF	.824	.000	.417	.000	.767	.688	.926	.000	.000	.926	.000	.000	.000	.000	.000	.000	.966	.766	.000	.979	.965

# Traffic Data Service

Campbell, CA  
 (408) 377-2988  
 tdsbay@cs.com

File Name : 16PM FINAL  
 Site Code : 00000016  
 Start Date : 11/10/2010  
 Page No : 2

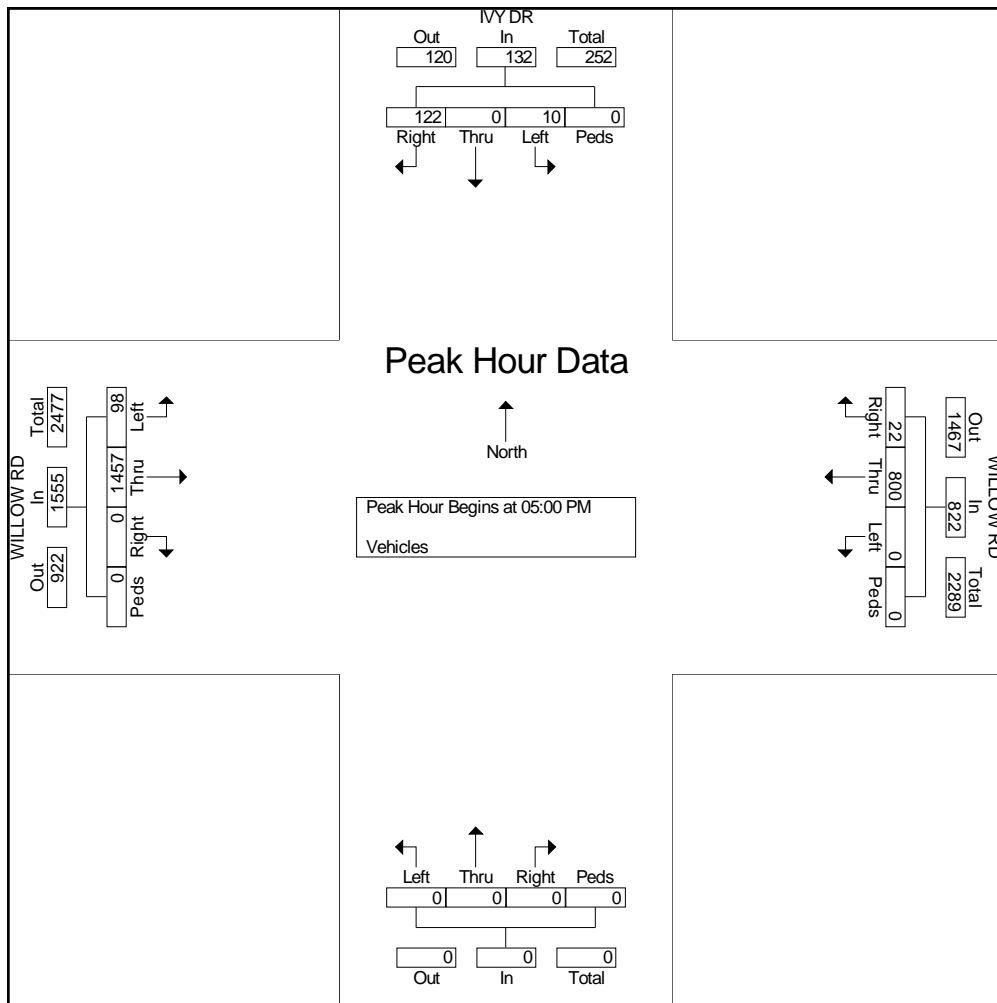

# Traffic Data Service

Campbell, CA  
(408) 377-2988  
tdsbay@cs.com

File Name : 17AM FINAL  
Site Code : 00000017  
Start Date : 11/16/2010  
Page No : 1

### Groups Printed- Vehicles

Start Time	Southbound					WILLOW RD Westbound					O'BRIEN DR Northbound					WILLOW RD Eastbound					Int. Total
	Right	Thru	Left	Peds	App. Total	Right	Thru	Left	Peds	App. Total	Right	Thru	Left	Peds	App. Total	Right	Thru	Left	Peds	App. Total	
07:00 AM	0	0	0	0	0	0	281	10	0	291	5	0	43	0	48	49	147	0	0	196	535
07:15 AM	0	0	0	0	0	0	327	8	0	335	8	0	45	0	53	52	139	0	0	191	579
07:30 AM	0	0	0	0	0	0	336	23	0	359	13	0	37	0	50	46	167	0	0	213	622
07:45 AM	0	0	0	0	0	0	209	16	0	225	15	0	36	0	51	52	179	0	0	231	507
<b>Total</b>	<b>0</b>	<b>0</b>	<b>0</b>	<b>0</b>	<b>0</b>	<b>0</b>	<b>1153</b>	<b>57</b>	<b>0</b>	<b>1210</b>	<b>41</b>	<b>0</b>	<b>161</b>	<b>0</b>	<b>202</b>	<b>199</b>	<b>632</b>	<b>0</b>	<b>0</b>	<b>831</b>	<b>2243</b>
08:00 AM	0	0	0	0	0	0	287	16	0	303	27	0	23	0	50	75	188	0	0	263	616
08:15 AM	0	0	0	0	0	0	244	38	0	282	19	0	34	0	53	61	180	0	0	241	576
08:30 AM	0	0	0	0	0	0	330	32	0	362	11	0	39	0	50	64	170	0	0	234	646
08:45 AM	0	0	0	0	0	0	310	16	0	326	10	0	34	0	44	50	159	0	0	209	579
<b>Total</b>	<b>0</b>	<b>0</b>	<b>0</b>	<b>0</b>	<b>0</b>	<b>0</b>	<b>1171</b>	<b>102</b>	<b>0</b>	<b>1273</b>	<b>67</b>	<b>0</b>	<b>130</b>	<b>0</b>	<b>197</b>	<b>250</b>	<b>697</b>	<b>0</b>	<b>0</b>	<b>947</b>	<b>2417</b>
Grand Total	0	0	0	0	0	0	2324	159	0	2483	108	0	291	0	399	449	1329	0	0	1778	4660
Apprch %	0	0	0	0	0	0	93.6	6.4	0		27.1	0	72.9	0		25.3	74.7	0	0		
Total %	0	0	0	0	0	0	49.9	3.4	0	53.3	2.3	0	6.2	0	8.6	9.6	28.5	0	0	38.2	

Start Time	Southbound					WILLOW RD Westbound					O'BRIEN DR Northbound					WILLOW RD Eastbound					Int. Total
	Right	Thru	Left	Peds	App. Total	Right	Thru	Left	Peds	App. Total	Right	Thru	Left	Peds	App. Total	Right	Thru	Left	Peds	App. Total	
Peak Hour Analysis From 07:00 AM to 08:45 AM - Peak 1 of 1																					
Peak Hour for Entire Intersection Begins at 08:00 AM																					
08:00 AM	0	0	0	0	0	0	287	16	0	303	27	0	23	0	50	75	188	0	0	263	616
08:15 AM	0	0	0	0	0	0	244	38	0	282	19	0	34	0	53	61	180	0	0	241	576
08:30 AM	0	0	0	0	0	0	330	32	0	362	11	0	39	0	50	64	170	0	0	234	646
08:45 AM	0	0	0	0	0	0	310	16	0	326	10	0	34	0	44	50	159	0	0	209	579
Total Volume	0	0	0	0	0	0	1171	102	0	1273	67	0	130	0	197	250	697	0	0	947	2417
% App. Total																					
PHF	.000	.000	.000	.000	.000	.000	.887	.671	.000	.879	.620	.000	.833	.000	.929	.833	.927	.000	.000	.900	.935

# Traffic Data Service

Campbell, CA  
 (408) 377-2988  
 tdsbay@cs.com

File Name : 17AM FINAL  
 Site Code : 00000017  
 Start Date : 11/16/2010  
 Page No : 2

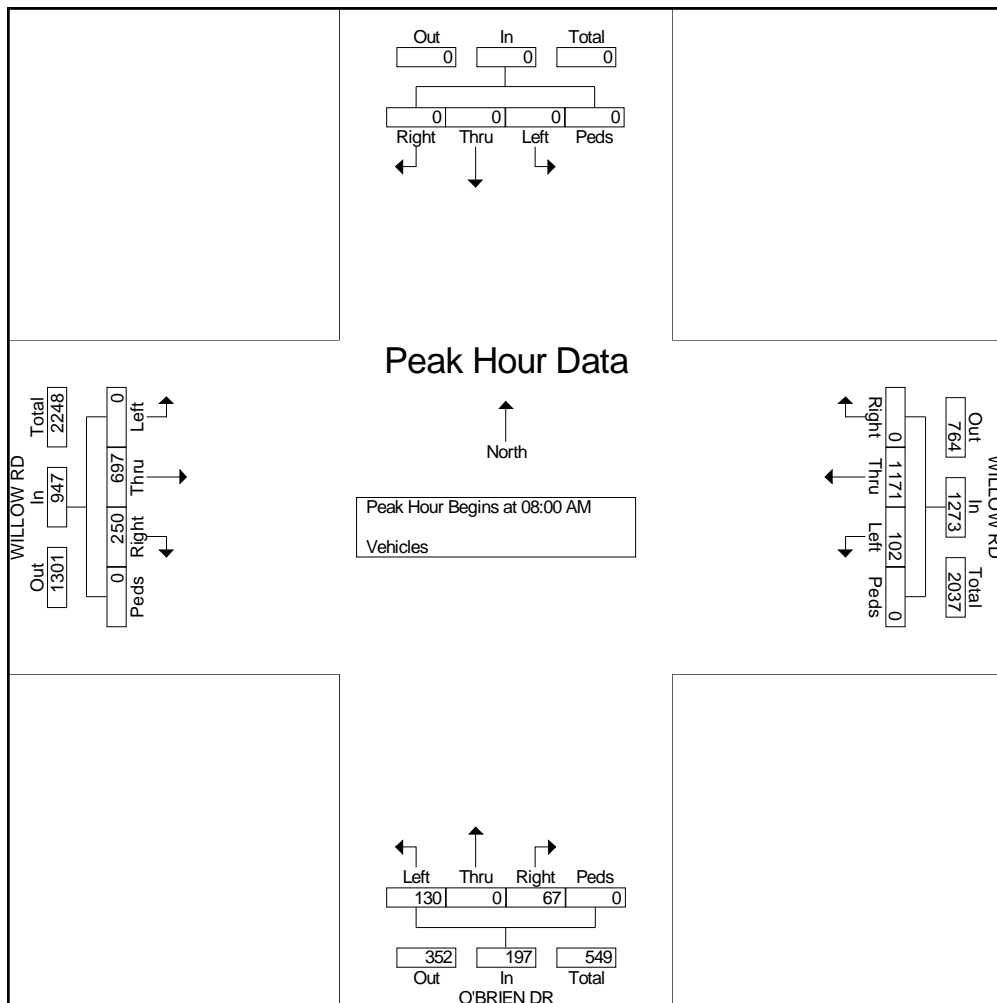

# Traffic Data Service

Campbell, CA  
(408) 377-2988  
tdsbay@cs.com

File Name : 17PM FINAL  
Site Code : 00000017  
Start Date : 11/16/2010  
Page No : 1

### Groups Printed- Vehicles

Start Time	Southbound					WILLOW RD Westbound					O'BRIEN DR Northbound					WILLOW RD Eastbound					Int. Total
	Right	Thru	Left	Peds	App. Total	Right	Thru	Left	Peds	App. Total	Right	Thru	Left	Peds	App. Total	Right	Thru	Left	Peds	App. Total	
04:00 PM	0	0	0	0	0	0	166	15	0	181	13	0	53	0	66	38	299	0	0	337	584
04:15 PM	0	0	0	0	0	0	174	11	0	185	12	0	44	0	56	38	334	0	0	372	613
04:30 PM	0	0	0	0	0	0	190	12	0	202	6	0	49	0	55	55	326	0	0	381	638
04:45 PM	0	0	0	0	0	0	227	12	0	239	14	0	54	0	68	41	326	0	0	367	674
<b>Total</b>	<b>0</b>	<b>0</b>	<b>0</b>	<b>0</b>	<b>0</b>	<b>0</b>	<b>757</b>	<b>50</b>	<b>0</b>	<b>807</b>	<b>45</b>	<b>0</b>	<b>200</b>	<b>0</b>	<b>245</b>	<b>172</b>	<b>1285</b>	<b>0</b>	<b>0</b>	<b>1457</b>	<b>2509</b>
05:00 PM	0	0	0	0	0	0	205	25	0	230	10	0	66	0	76	40	347	0	0	387	693
05:15 PM	0	0	0	0	0	0	234	16	0	250	12	0	52	0	64	57	355	0	0	412	726
05:30 PM	0	0	0	0	0	0	208	18	0	226	7	0	48	0	55	51	360	0	0	411	692
05:45 PM	0	0	0	0	0	0	241	14	0	255	6	0	44	0	50	56	351	0	0	407	712
<b>Total</b>	<b>0</b>	<b>0</b>	<b>0</b>	<b>0</b>	<b>0</b>	<b>0</b>	<b>888</b>	<b>73</b>	<b>0</b>	<b>961</b>	<b>35</b>	<b>0</b>	<b>210</b>	<b>0</b>	<b>245</b>	<b>204</b>	<b>1413</b>	<b>0</b>	<b>0</b>	<b>1617</b>	<b>2823</b>
Grand Total	0	0	0	0	0	0	1645	123	0	1768	80	0	410	0	490	376	2698	0	0	3074	5332
Apprch %	0	0	0	0	0	0	93	7	0	100	16.3	0	83.7	0	100	12.2	87.8	0	0	100	
Total %	0	0	0	0	0	0	30.9	2.3	0	33.2	1.5	0	7.7	0	9.2	7.1	50.6	0	0	57.7	

Start Time	Southbound					WILLOW RD Westbound					O'BRIEN DR Northbound					WILLOW RD Eastbound					Int. Total
	Right	Thru	Left	Peds	App. Total	Right	Thru	Left	Peds	App. Total	Right	Thru	Left	Peds	App. Total	Right	Thru	Left	Peds	App. Total	
Peak Hour Analysis From 04:00 PM to 05:45 PM - Peak 1 of 1																					
Peak Hour for Entire Intersection Begins at 05:00 PM																					
05:00 PM	0	0	0	0	0	0	205	25	0	230	10	0	66	0	76	40	347	0	0	387	693
05:15 PM	0	0	0	0	0	0	234	16	0	250	12	0	52	0	64	57	355	0	0	412	726
05:30 PM	0	0	0	0	0	0	208	18	0	226	7	0	48	0	55	51	360	0	0	411	692
05:45 PM	0	0	0	0	0	0	241	14	0	255	6	0	44	0	50	56	351	0	0	407	712
Total Volume	0	0	0	0	0	0	888	73	0	961	35	0	210	0	245	204	1413	0	0	1617	2823
% App. Total																					
PHF	.000	.000	.000	.000	.000	.000	.921	.730	.000	.942	.729	.000	.795	.000	.806	.895	.981	.000	.000	.981	.972



# Traffic Data Service

Campbell, CA  
 (408) 377-2988  
 tdsbay@cs.com

File Name : 17PM FINAL  
 Site Code : 00000017  
 Start Date : 11/16/2010  
 Page No : 2

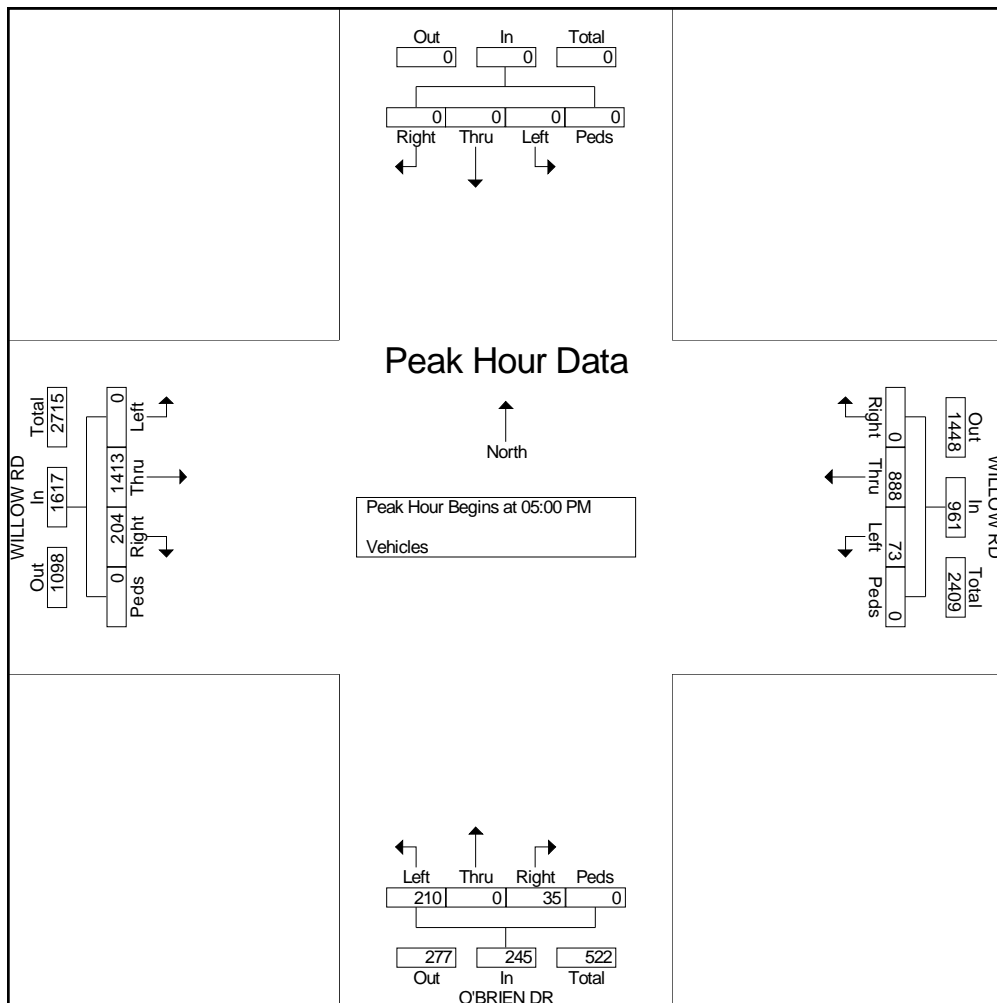

# Traffic Data Service

Campbell, CA  
(408) 377-2988  
tdsbay@cs.com

File Name : 18AM FINAL  
Site Code : 00000018  
Start Date : 11/16/2010  
Page No : 1

### Groups Printed- Vehicles

Start Time	NEWBRIDGE ST Southbound					WILLOW RD Westbound					NEWBRIDGE ST Northbound					WILLOW RD Eastbound					Int. Total
	Right	Thru	Left	Peds	App. Total	Right	Thru	Left	Peds	App. Total	Right	Thru	Left	Peds	App. Total	Right	Thru	Left	Peds	App. Total	
07:00 AM	65	34	4	0	103	1	297	1	0	299	7	18	75	0	100	24	137	19	0	180	682
07:15 AM	111	38	6	0	155	2	345	2	0	349	6	18	86	0	110	27	173	37	0	237	851
07:30 AM	113	37	6	0	156	0	347	8	0	355	7	17	110	0	134	27	205	33	0	265	910
07:45 AM	70	52	6	0	128	0	260	6	0	266	11	31	88	0	130	36	222	35	0	293	817
<b>Total</b>	<b>359</b>	<b>161</b>	<b>22</b>	<b>0</b>	<b>542</b>	<b>3</b>	<b>1249</b>	<b>17</b>	<b>0</b>	<b>1269</b>	<b>31</b>	<b>84</b>	<b>359</b>	<b>0</b>	<b>474</b>	<b>114</b>	<b>737</b>	<b>124</b>	<b>0</b>	<b>975</b>	<b>3260</b>
08:00 AM	90	51	10	0	151	2	269	12	0	283	12	45	66	0	123	65	226	43	0	334	891
08:15 AM	73	54	21	0	148	0	239	10	0	249	21	38	62	0	121	44	217	36	0	297	815
08:30 AM	56	38	6	0	100	5	335	15	0	355	11	27	66	0	104	37	204	32	0	273	832
08:45 AM	65	30	1	0	96	2	308	21	0	331	12	24	49	0	85	23	181	20	0	224	736
<b>Total</b>	<b>284</b>	<b>173</b>	<b>38</b>	<b>0</b>	<b>495</b>	<b>9</b>	<b>1151</b>	<b>58</b>	<b>0</b>	<b>1218</b>	<b>56</b>	<b>134</b>	<b>243</b>	<b>0</b>	<b>433</b>	<b>169</b>	<b>828</b>	<b>131</b>	<b>0</b>	<b>1128</b>	<b>3274</b>
<b>Grand Total</b>	<b>643</b>	<b>334</b>	<b>60</b>	<b>0</b>	<b>1037</b>	<b>12</b>	<b>2400</b>	<b>75</b>	<b>0</b>	<b>2487</b>	<b>87</b>	<b>218</b>	<b>602</b>	<b>0</b>	<b>907</b>	<b>283</b>	<b>1565</b>	<b>255</b>	<b>0</b>	<b>2103</b>	<b>6534</b>
<b>Apprch %</b>	<b>62</b>	<b>32.2</b>	<b>5.8</b>	<b>0</b>		<b>0.5</b>	<b>96.5</b>	<b>3</b>	<b>0</b>		<b>9.6</b>	<b>24</b>	<b>66.4</b>	<b>0</b>		<b>13.5</b>	<b>74.4</b>	<b>12.1</b>	<b>0</b>		
<b>Total %</b>	<b>9.8</b>	<b>5.1</b>	<b>0.9</b>	<b>0</b>	<b>15.9</b>	<b>0.2</b>	<b>36.7</b>	<b>1.1</b>	<b>0</b>	<b>38.1</b>	<b>1.3</b>	<b>3.3</b>	<b>9.2</b>	<b>0</b>	<b>13.9</b>	<b>4.3</b>	<b>24</b>	<b>3.9</b>	<b>0</b>	<b>32.2</b>	

Start Time	NEWBRIDGE ST Southbound					WILLOW RD Westbound					NEWBRIDGE ST Northbound					WILLOW RD Eastbound					Int. Total
	Right	Thru	Left	Peds	App. Total	Right	Thru	Left	Peds	App. Total	Right	Thru	Left	Peds	App. Total	Right	Thru	Left	Peds	App. Total	
Peak Hour Analysis From 07:00 AM to 08:45 AM - Peak 1 of 1																					
Peak Hour for Entire Intersection Begins at 07:15 AM																					
07:15 AM	111	38	6	0	155	2	345	2	0	349	6	18	86	0	110	27	173	37	0	237	851
07:30 AM	113	37	6	0	156	0	347	8	0	355	7	17	110	0	134	27	205	33	0	265	910
07:45 AM	70	52	6	0	128	0	260	6	0	266	11	31	88	0	130	36	222	35	0	293	817
08:00 AM	90	51	10	0	151	2	269	12	0	283	12	45	66	0	123	65	226	43	0	334	891
<b>Total Volume</b>	<b>384</b>	<b>178</b>	<b>28</b>	<b>0</b>	<b>590</b>	<b>4</b>	<b>1221</b>	<b>28</b>	<b>0</b>	<b>1253</b>	<b>36</b>	<b>111</b>	<b>350</b>	<b>0</b>	<b>497</b>	<b>155</b>	<b>826</b>	<b>148</b>	<b>0</b>	<b>1129</b>	<b>3469</b>
<b>% App. Total</b>																					
<b>PHF</b>	<b>.850</b>	<b>.856</b>	<b>.700</b>	<b>.000</b>	<b>.946</b>	<b>.500</b>	<b>.880</b>	<b>.583</b>	<b>.000</b>	<b>.882</b>	<b>.750</b>	<b>.617</b>	<b>.795</b>	<b>.000</b>	<b>.927</b>	<b>.596</b>	<b>.914</b>	<b>.860</b>	<b>.000</b>	<b>.845</b>	<b>.953</b>

# Traffic Data Service

Campbell, CA  
 (408) 377-2988  
 tdsbay@cs.com

File Name : 18AM FINAL  
 Site Code : 00000018  
 Start Date : 11/16/2010  
 Page No : 2

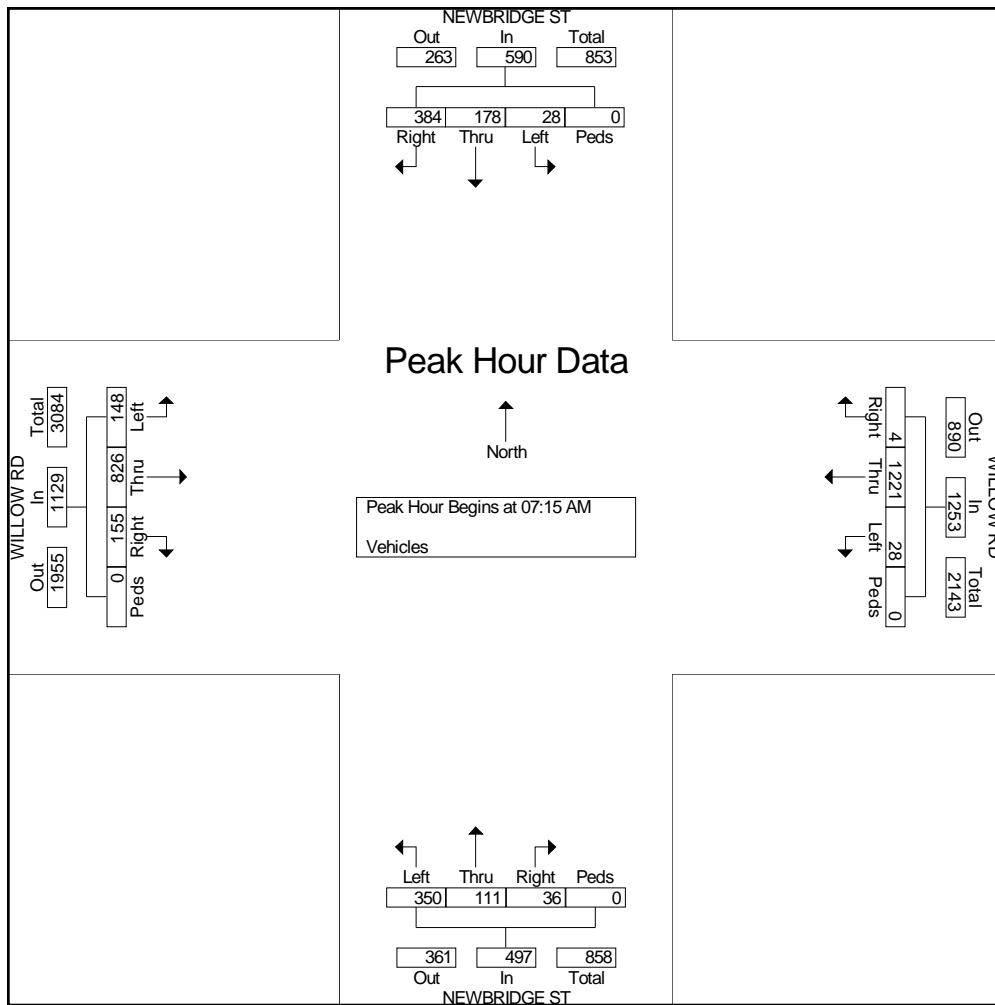

# Traffic Data Service

Campbell, CA  
(408) 377-2988  
tdsbay@cs.com

File Name : 18PM FINAL  
Site Code : 00000018  
Start Date : 11/16/2010  
Page No : 1

### Groups Printed- Vehicles

Start Time	NEWBRIDGE ST Southbound					WILLOW RD Westbound					NEWBRIDGE ST Northbound					WILLOW RD Eastbound					Int. Total
	Right	Thru	Left	Peds	App. Total	Right	Thru	Left	Peds	App. Total	Right	Thru	Left	Peds	App. Total	Right	Thru	Left	Peds	App. Total	
04:00 PM	45	40	5	0	90	12	184	27	0	223	8	32	62	0	102	60	311	73	0	444	859
04:15 PM	58	33	3	0	94	2	180	18	0	200	11	42	62	0	115	88	327	76	0	491	900
04:30 PM	50	36	6	0	92	5	213	31	0	249	11	33	59	0	103	67	348	63	0	478	922
04:45 PM	45	34	11	0	90	10	231	19	0	260	17	46	72	0	135	70	318	77	0	465	950
<b>Total</b>	<b>198</b>	<b>143</b>	<b>25</b>	<b>0</b>	<b>366</b>	<b>29</b>	<b>808</b>	<b>95</b>	<b>0</b>	<b>932</b>	<b>47</b>	<b>153</b>	<b>255</b>	<b>0</b>	<b>455</b>	<b>285</b>	<b>1304</b>	<b>289</b>	<b>0</b>	<b>1878</b>	<b>3631</b>
05:00 PM	51	41	9	0	101	5	223	21	0	249	14	29	51	0	94	71	359	85	0	515	959
05:15 PM	59	36	9	0	104	9	261	13	0	283	14	56	69	0	139	90	322	87	0	499	1025
05:30 PM	61	42	6	0	109	10	236	30	0	276	16	49	72	0	137	76	397	85	0	558	1080
05:45 PM	48	47	14	0	109	10	255	38	0	303	11	36	56	0	103	102	358	66	0	526	1041
<b>Total</b>	<b>219</b>	<b>166</b>	<b>38</b>	<b>0</b>	<b>423</b>	<b>34</b>	<b>975</b>	<b>102</b>	<b>0</b>	<b>1111</b>	<b>55</b>	<b>170</b>	<b>248</b>	<b>0</b>	<b>473</b>	<b>339</b>	<b>1436</b>	<b>323</b>	<b>0</b>	<b>2098</b>	<b>4105</b>
<b>Grand Total</b>	<b>417</b>	<b>309</b>	<b>63</b>	<b>0</b>	<b>789</b>	<b>63</b>	<b>1783</b>	<b>197</b>	<b>0</b>	<b>2043</b>	<b>102</b>	<b>323</b>	<b>503</b>	<b>0</b>	<b>928</b>	<b>624</b>	<b>2740</b>	<b>612</b>	<b>0</b>	<b>3976</b>	<b>7736</b>
<b>Apprch %</b>	<b>52.9</b>	<b>39.2</b>	<b>8</b>	<b>0</b>		<b>3.1</b>	<b>87.3</b>	<b>9.6</b>	<b>0</b>		<b>11</b>	<b>34.8</b>	<b>54.2</b>	<b>0</b>		<b>15.7</b>	<b>68.9</b>	<b>15.4</b>	<b>0</b>		
<b>Total %</b>	<b>5.4</b>	<b>4</b>	<b>0.8</b>	<b>0</b>	<b>10.2</b>	<b>0.8</b>	<b>23</b>	<b>2.5</b>	<b>0</b>	<b>26.4</b>	<b>1.3</b>	<b>4.2</b>	<b>6.5</b>	<b>0</b>	<b>12</b>	<b>8.1</b>	<b>35.4</b>	<b>7.9</b>	<b>0</b>	<b>51.4</b>	

Start Time	NEWBRIDGE ST Southbound					WILLOW RD Westbound					NEWBRIDGE ST Northbound					WILLOW RD Eastbound					Int. Total
	Right	Thru	Left	Peds	App. Total	Right	Thru	Left	Peds	App. Total	Right	Thru	Left	Peds	App. Total	Right	Thru	Left	Peds	App. Total	
Peak Hour Analysis From 04:00 PM to 05:45 PM - Peak 1 of 1																					
Peak Hour for Entire Intersection Begins at 05:00 PM																					
05:00 PM	51	41	9	0	101	5	223	21	0	249	14	29	51	0	94	71	359	85	0	515	959
05:15 PM	59	36	9	0	104	9	261	13	0	283	14	56	69	0	139	90	322	87	0	499	1025
05:30 PM	61	42	6	0	109	10	236	30	0	276	16	49	72	0	137	76	397	85	0	558	1080
05:45 PM	48	47	14	0	109	10	255	38	0	303	11	36	56	0	103	102	358	66	0	526	1041
<b>Total Volume</b>	<b>219</b>	<b>166</b>	<b>38</b>	<b>0</b>	<b>423</b>	<b>34</b>	<b>975</b>	<b>102</b>	<b>0</b>	<b>1111</b>	<b>55</b>	<b>170</b>	<b>248</b>	<b>0</b>	<b>473</b>	<b>339</b>	<b>1436</b>	<b>323</b>	<b>0</b>	<b>2098</b>	<b>4105</b>
<b>% App. Total</b>																					
<b>PHF</b>	<b>.898</b>	<b>.883</b>	<b>.679</b>	<b>.000</b>	<b>.970</b>	<b>.850</b>	<b>.934</b>	<b>.671</b>	<b>.000</b>	<b>.917</b>	<b>.859</b>	<b>.759</b>	<b>.861</b>	<b>.000</b>	<b>.851</b>	<b>.831</b>	<b>.904</b>	<b>.928</b>	<b>.000</b>	<b>.940</b>	<b>.950</b>

# Traffic Data Service

Campbell, CA  
 (408) 377-2988  
 tdsbay@cs.com

File Name : 18PM FINAL  
 Site Code : 00000018  
 Start Date : 11/16/2010  
 Page No : 2

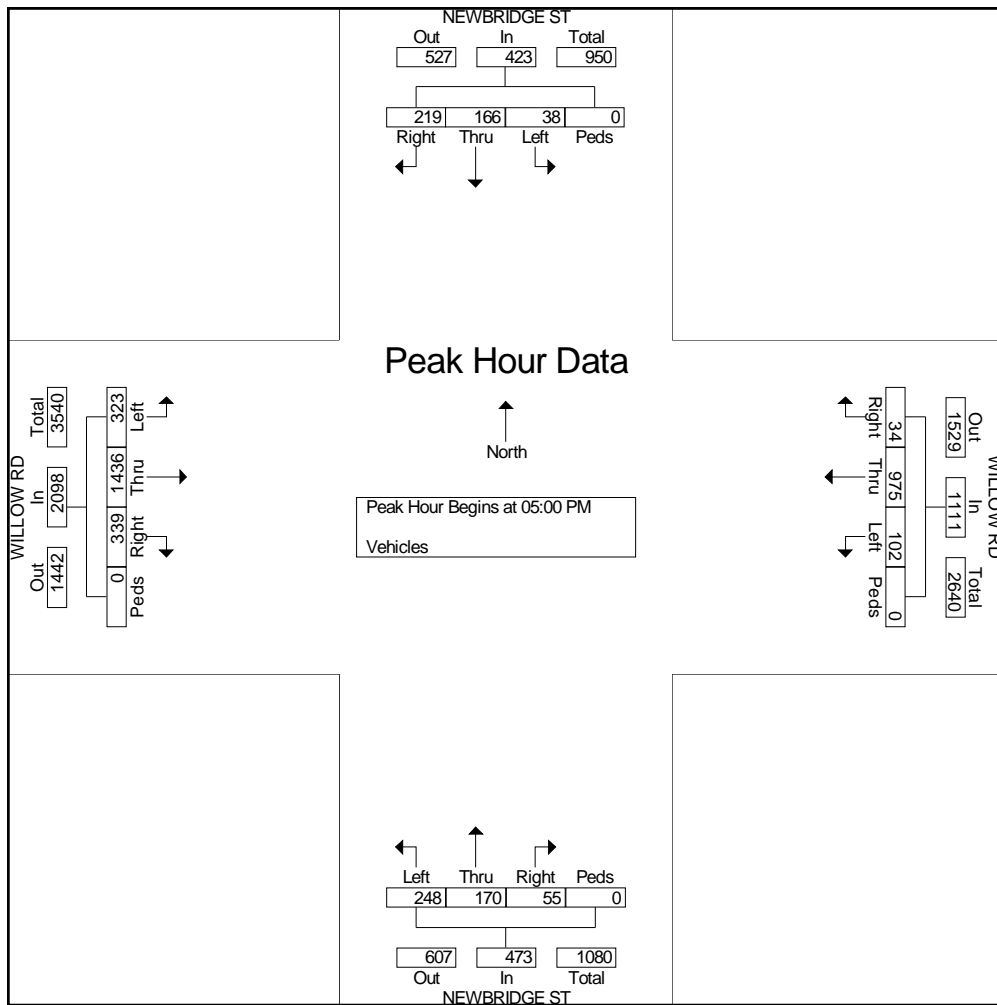

# Traffic Data Service

Campbell, CA  
(408) 377-2988  
tdsbay@cs.com

File Name : 19AM FINAL  
Site Code : 00000019  
Start Date : 11/16/2010  
Page No : 1

### Groups Printed- Vehicles

Start Time	BAY RD Southbound					WILLOW RD Westbound					Northbound					WILLOW RD Eastbound					Int. Total
	Right	Thru	Left	Peds	App. Total	Right	Thru	Left	Peds	App. Total	Right	Thru	Left	Peds	App. Total	Right	Thru	Left	Peds	App. Total	
07:00 AM	3	0	31	0	34	53	297	0	0	350	0	0	0	0	0	0	205	7	0	212	596
07:15 AM	8	0	51	0	59	95	296	0	0	391	0	0	0	0	0	0	244	7	0	251	701
07:30 AM	5	0	72	0	77	100	295	0	0	395	0	0	0	0	0	0	311	9	0	320	792
07:45 AM	19	0	90	0	109	105	274	0	0	379	0	0	0	0	0	0	325	15	0	340	828
<b>Total</b>	<b>35</b>	<b>0</b>	<b>244</b>	<b>0</b>	<b>279</b>	<b>353</b>	<b>1162</b>	<b>0</b>	<b>0</b>	<b>1515</b>	<b>0</b>	<b>0</b>	<b>0</b>	<b>0</b>	<b>0</b>	<b>0</b>	<b>1085</b>	<b>38</b>	<b>0</b>	<b>1123</b>	<b>2917</b>
08:00 AM	28	0	96	0	124	52	251	0	0	303	0	0	0	0	0	0	403	23	0	426	853
08:15 AM	23	0	103	0	126	62	294	0	0	356	0	0	0	0	0	0	339	17	0	356	838
08:30 AM	16	0	107	0	123	76	278	0	0	354	0	0	0	0	0	0	296	12	0	308	785
08:45 AM	24	0	64	0	88	80	254	0	0	334	0	0	0	0	0	0	310	10	0	320	742
<b>Total</b>	<b>91</b>	<b>0</b>	<b>370</b>	<b>0</b>	<b>461</b>	<b>270</b>	<b>1077</b>	<b>0</b>	<b>0</b>	<b>1347</b>	<b>0</b>	<b>0</b>	<b>0</b>	<b>0</b>	<b>0</b>	<b>0</b>	<b>1348</b>	<b>62</b>	<b>0</b>	<b>1410</b>	<b>3218</b>
Grand Total	126	0	614	0	740	623	2239	0	0	2862	0	0	0	0	0	0	2433	100	0	2533	6135
Apprch %	17	0	83	0	12.1	21.8	78.2	0	0	46.7	0	0	0	0	0	0	96.1	3.9	0	41.3	
Total %	2.1	0	10	0	12.1	10.2	36.5	0	0	46.7	0	0	0	0	0	0	39.7	1.6	0	41.3	

Start Time	BAY RD Southbound					WILLOW RD Westbound					Northbound					WILLOW RD Eastbound					Int. Total
	Right	Thru	Left	Peds	App. Total	Right	Thru	Left	Peds	App. Total	Right	Thru	Left	Peds	App. Total	Right	Thru	Left	Peds	App. Total	
Peak Hour Analysis From 07:00 AM to 08:45 AM - Peak 1 of 1																					
Peak Hour for Entire Intersection Begins at 07:30 AM																					
07:30 AM	5	0	72	0	77	100	295	0	0	395	0	0	0	0	0	0	311	9	0	320	792
07:45 AM	19	0	90	0	109	105	274	0	0	379	0	0	0	0	0	0	325	15	0	340	828
08:00 AM	28	0	96	0	124	52	251	0	0	303	0	0	0	0	0	0	403	23	0	426	853
08:15 AM	23	0	103	0	126	62	294	0	0	356	0	0	0	0	0	0	339	17	0	356	838
Total Volume	75	0	361	0	436	319	1114	0	0	1433	0	0	0	0	0	0	1378	64	0	1442	3311
% App. Total																					
PHF	.670	.000	.876	.000	.865	.760	.944	.000	.000	.907	.000	.000	.000	.000	.000	.000	.855	.696	.000	.846	.970

# Traffic Data Service

Campbell, CA  
 (408) 377-2988  
 tdsbay@cs.com

File Name : 19AM FINAL  
 Site Code : 00000019  
 Start Date : 11/16/2010  
 Page No : 2

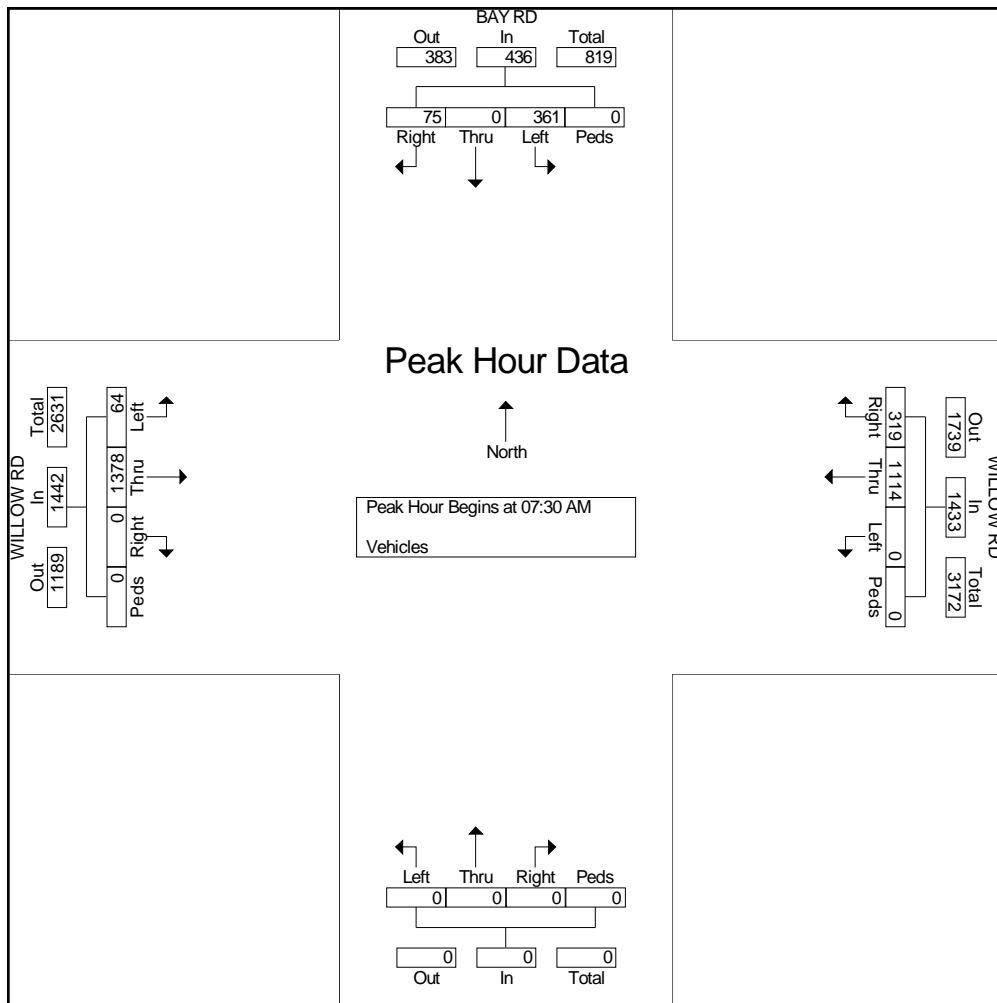

# Traffic Data Service

Campbell, CA  
(408) 377-2988  
tdsbay@cs.com

File Name : 19PM FINAL  
Site Code : 00000019  
Start Date : 11/16/2010  
Page No : 1

### Groups Printed- Vehicles

Start Time	BAY RD Southbound					WILLOW RD Westbound					Northbound					WILLOW RD Eastbound					Int. Total
	Right	Thru	Left	Peds	App. Total	Right	Thru	Left	Peds	App. Total	Right	Thru	Left	Peds	App. Total	Right	Thru	Left	Peds	App. Total	
04:00 PM	15	0	91	0	106	41	200	0	0	241	0	0	0	0	0	0	359	15	0	374	721
04:15 PM	10	0	76	0	86	42	247	0	0	289	0	0	0	0	0	0	369	15	0	384	759
04:30 PM	10	0	75	0	85	37	233	0	0	270	0	0	0	0	0	0	367	11	0	378	733
04:45 PM	12	0	122	0	134	69	245	0	0	314	0	0	0	0	0	0	374	13	0	387	835
<b>Total</b>	<b>47</b>	<b>0</b>	<b>364</b>	<b>0</b>	<b>411</b>	<b>189</b>	<b>925</b>	<b>0</b>	<b>0</b>	<b>1114</b>	<b>0</b>	<b>0</b>	<b>0</b>	<b>0</b>	<b>0</b>	<b>0</b>	<b>1469</b>	<b>54</b>	<b>0</b>	<b>1523</b>	<b>3048</b>
05:00 PM	14	0	95	0	109	55	272	0	0	327	0	0	0	0	0	0	354	16	0	370	806
05:15 PM	15	0	99	0	114	58	258	0	0	316	0	0	0	0	0	0	362	7	0	369	799
05:30 PM	13	0	100	0	113	73	286	0	0	359	0	0	0	0	0	0	346	4	0	350	822
05:45 PM	21	0	73	0	94	53	298	0	0	351	0	0	0	0	0	0	320	22	0	342	787
<b>Total</b>	<b>63</b>	<b>0</b>	<b>367</b>	<b>0</b>	<b>430</b>	<b>239</b>	<b>1114</b>	<b>0</b>	<b>0</b>	<b>1353</b>	<b>0</b>	<b>0</b>	<b>0</b>	<b>0</b>	<b>0</b>	<b>0</b>	<b>1382</b>	<b>49</b>	<b>0</b>	<b>1431</b>	<b>3214</b>
Grand Total	110	0	731	0	841	428	2039	0	0	2467	0	0	0	0	0	0	2851	103	0	2954	6262
Apprch %	13.1	0	86.9	0		17.3	82.7	0	0		0	0	0	0		0	96.5	3.5	0		
Total %	1.8	0	11.7	0	13.4	6.8	32.6	0	0	39.4	0	0	0	0	0	0	45.5	1.6	0	47.2	

Start Time	BAY RD Southbound					WILLOW RD Westbound					Northbound					WILLOW RD Eastbound					Int. Total
	Right	Thru	Left	Peds	App. Total	Right	Thru	Left	Peds	App. Total	Right	Thru	Left	Peds	App. Total	Right	Thru	Left	Peds	App. Total	
Peak Hour Analysis From 04:00 PM to 05:45 PM - Peak 1 of 1																					
Peak Hour for Entire Intersection Begins at 04:45 PM																					
04:45 PM	12	0	122	0	134	69	245	0	0	314	0	0	0	0	0	0	374	13	0	387	835
05:00 PM	14	0	95	0	109	55	272	0	0	327	0	0	0	0	0	0	354	16	0	370	806
05:15 PM	15	0	99	0	114	58	258	0	0	316	0	0	0	0	0	0	362	7	0	369	799
05:30 PM	13	0	100	0	113	73	286	0	0	359	0	0	0	0	0	0	346	4	0	350	822
Total Volume	54	0	416	0	470	255	1061	0	0	1316	0	0	0	0	0	0	1436	40	0	1476	3262
% App. Total																					
PHF	.900	.000	.852	.000	.877	.873	.927	.000	.000	.916	.000	.000	.000	.000	.000	.000	.960	.625	.000	.953	.977



# Traffic Data Service

Campbell, CA  
 (408) 377-2988  
 tdsbay@cs.com

File Name : 19PM FINAL  
 Site Code : 00000019  
 Start Date : 11/16/2010  
 Page No : 2

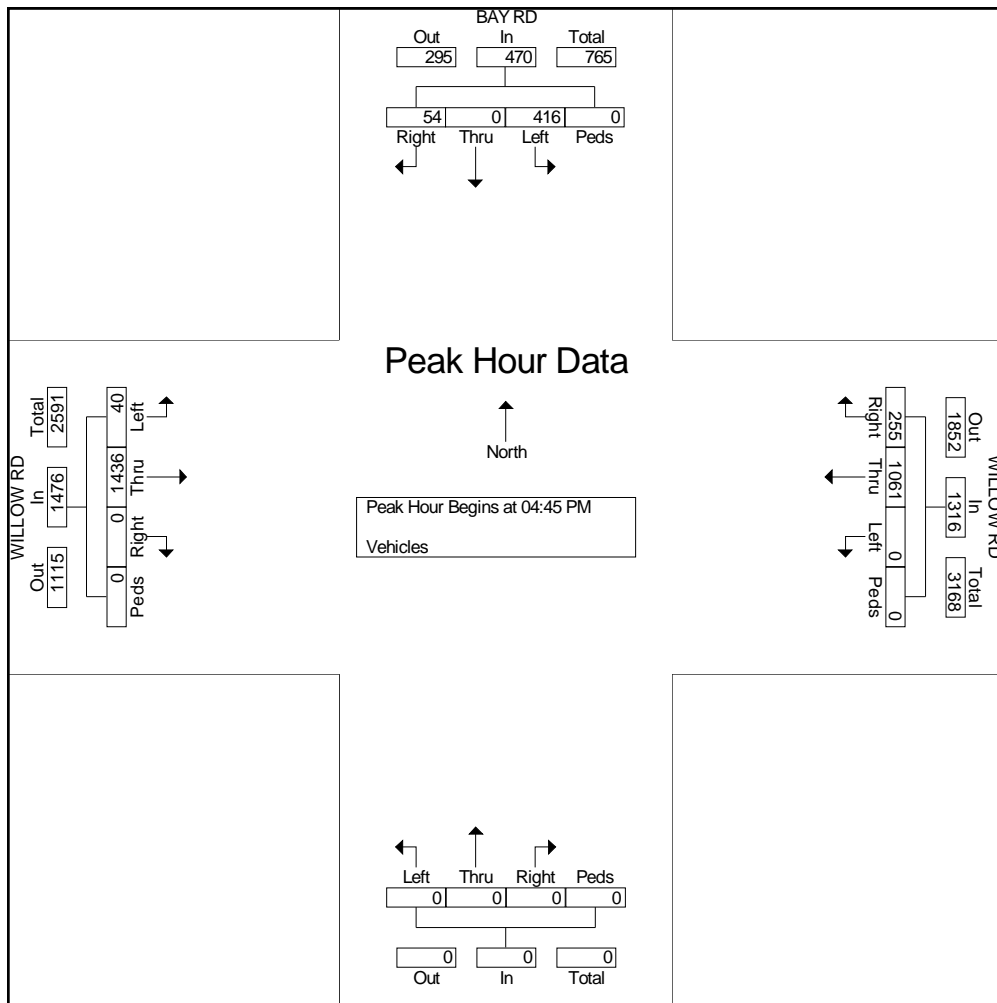

# Traffic Data Service

Campbell, CA  
(408) 377-2988  
tdsbay@cs.com

File Name : 20AM FINAL  
Site Code : 00000020  
Start Date : 11/16/2010  
Page No : 1

### Groups Printed- Vehicles

Start Time	HOSPITAL PZ Southbound					WILLOW RD Westbound					DURHAM ST Northbound					WILLOW RD Eastbound					Int. Total
	Right	Thru	Left	Peds	App. Total	Right	Thru	Left	Peds	App. Total	Right	Thru	Left	Peds	App. Total	Right	Thru	Left	Peds	App. Total	
07:00 AM	2	2	11	0	15	54	237	9	0	300	7	5	5	0	17	2	163	4	0	169	501
07:15 AM	3	4	8	0	15	40	233	11	0	284	17	4	7	0	28	2	184	1	0	187	514
07:30 AM	1	0	19	0	20	31	228	8	0	267	23	6	14	0	43	2	226	5	0	233	563
07:45 AM	0	1	2	0	3	37	206	9	0	252	25	2	15	0	42	3	268	2	0	273	570
<b>Total</b>	<b>6</b>	<b>7</b>	<b>40</b>	<b>0</b>	<b>53</b>	<b>162</b>	<b>904</b>	<b>37</b>	<b>0</b>	<b>1103</b>	<b>72</b>	<b>17</b>	<b>41</b>	<b>0</b>	<b>130</b>	<b>9</b>	<b>841</b>	<b>12</b>	<b>0</b>	<b>862</b>	<b>2148</b>
08:00 AM	0	0	4	0	4	42	192	13	0	247	46	2	19	0	67	1	251	3	0	255	573
08:15 AM	1	1	13	0	15	32	224	11	0	267	31	6	14	0	51	3	256	2	0	261	594
08:30 AM	0	1	9	0	10	24	226	16	0	266	25	5	10	0	40	1	231	5	0	237	553
08:45 AM	0	1	14	0	15	33	197	11	0	241	32	2	14	0	48	2	223	6	0	231	535
<b>Total</b>	<b>1</b>	<b>3</b>	<b>40</b>	<b>0</b>	<b>44</b>	<b>131</b>	<b>839</b>	<b>51</b>	<b>0</b>	<b>1021</b>	<b>134</b>	<b>15</b>	<b>57</b>	<b>0</b>	<b>206</b>	<b>7</b>	<b>961</b>	<b>16</b>	<b>0</b>	<b>984</b>	<b>2255</b>
<b>Grand Total</b>	<b>7</b>	<b>10</b>	<b>80</b>	<b>0</b>	<b>97</b>	<b>293</b>	<b>1743</b>	<b>88</b>	<b>0</b>	<b>2124</b>	<b>206</b>	<b>32</b>	<b>98</b>	<b>0</b>	<b>336</b>	<b>16</b>	<b>1802</b>	<b>28</b>	<b>0</b>	<b>1846</b>	<b>4403</b>
Apprch %	7.2	10.3	82.5	0		13.8	82.1	4.1	0		61.3	9.5	29.2	0		0.9	97.6	1.5	0		
Total %	0.2	0.2	1.8	0	2.2	6.7	39.6	2	0	48.2	4.7	0.7	2.2	0	7.6	0.4	40.9	0.6	0	41.9	

Start Time	HOSPITAL PZ Southbound					WILLOW RD Westbound					DURHAM ST Northbound					WILLOW RD Eastbound					Int. Total
	Right	Thru	Left	Peds	App. Total	Right	Thru	Left	Peds	App. Total	Right	Thru	Left	Peds	App. Total	Right	Thru	Left	Peds	App. Total	
Peak Hour Analysis From 07:00 AM to 08:45 AM - Peak 1 of 1																					
Peak Hour for Entire Intersection Begins at 07:30 AM																					
07:30 AM	1	0	19	0	20	31	228	8	0	267	23	6	14	0	43	2	226	5	0	233	563
07:45 AM	0	1	2	0	3	37	206	9	0	252	25	2	15	0	42	3	268	2	0	273	570
08:00 AM	0	0	4	0	4	42	192	13	0	247	46	2	19	0	67	1	251	3	0	255	573
08:15 AM	1	1	13	0	15	32	224	11	0	267	31	6	14	0	51	3	256	2	0	261	594
<b>Total Volume</b>	<b>2</b>	<b>2</b>	<b>38</b>	<b>0</b>	<b>42</b>	<b>142</b>	<b>850</b>	<b>41</b>	<b>0</b>	<b>1033</b>	<b>125</b>	<b>16</b>	<b>62</b>	<b>0</b>	<b>203</b>	<b>9</b>	<b>1001</b>	<b>12</b>	<b>0</b>	<b>1022</b>	<b>2300</b>
<b>% App. Total</b>																					
PHF	.500	.500	.500	.000	.525	.845	.932	.788	.000	.967	.679	.667	.816	.000	.757	.750	.934	.600	.000	.936	.968

# Traffic Data Service

Campbell, CA  
 (408) 377-2988  
 tdsbay@cs.com

File Name : 20AM FINAL  
 Site Code : 00000020  
 Start Date : 11/16/2010  
 Page No : 2

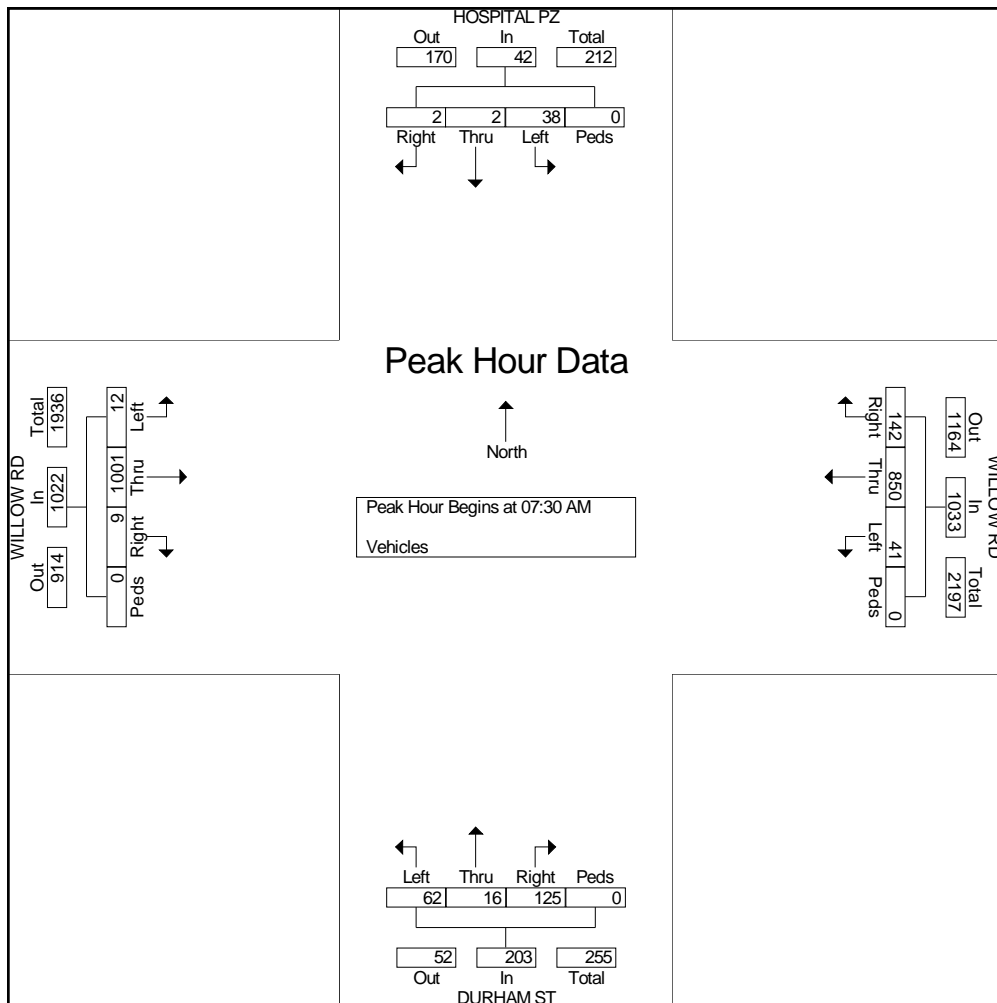

# Traffic Data Service

Campbell, CA  
(408) 377-2988  
tdsbay@cs.com

File Name : 20PM FINAL  
Site Code : 00000020  
Start Date : 11/16/2010  
Page No : 1

### Groups Printed- Vehicles

Start Time	HOSPITAL PZ Southbound					WILLOW RD Westbound					DURHAM ST Northbound					WILLOW RD Eastbound					Int. Total
	Right	Thru	Left	Peds	App. Total	Right	Thru	Left	Peds	App. Total	Right	Thru	Left	Peds	App. Total	Right	Thru	Left	Peds	App. Total	
04:00 PM	7	1	57	0	65	6	162	15	0	183	17	4	7	0	28	2	275	1	0	278	554
04:15 PM	6	2	34	0	42	11	170	32	0	213	25	0	8	0	33	5	294	2	0	301	589
04:30 PM	1	1	63	0	65	9	174	24	0	207	16	1	5	0	22	2	238	3	0	243	537
04:45 PM	7	1	28	0	36	17	185	24	0	226	20	1	12	0	33	2	281	2	0	285	580
<b>Total</b>	<b>21</b>	<b>5</b>	<b>182</b>	<b>0</b>	<b>208</b>	<b>43</b>	<b>691</b>	<b>95</b>	<b>0</b>	<b>829</b>	<b>78</b>	<b>6</b>	<b>32</b>	<b>0</b>	<b>116</b>	<b>11</b>	<b>1088</b>	<b>8</b>	<b>0</b>	<b>1107</b>	<b>2260</b>
05:00 PM	9	1	35	0	45	16	206	25	0	247	23	2	9	0	34	5	291	0	0	296	622
05:15 PM	9	0	30	0	39	5	187	19	0	211	28	2	9	0	39	0	277	3	0	280	569
05:30 PM	6	3	29	0	38	13	240	22	0	275	14	2	3	0	19	3	276	6	0	285	617
05:45 PM	0	1	20	0	21	6	231	28	0	265	26	1	4	0	31	3	256	2	0	261	578
<b>Total</b>	<b>24</b>	<b>5</b>	<b>114</b>	<b>0</b>	<b>143</b>	<b>40</b>	<b>864</b>	<b>94</b>	<b>0</b>	<b>998</b>	<b>91</b>	<b>7</b>	<b>25</b>	<b>0</b>	<b>123</b>	<b>11</b>	<b>1100</b>	<b>11</b>	<b>0</b>	<b>1122</b>	<b>2386</b>
Grand Total	45	10	296	0	351	83	1555	189	0	1827	169	13	57	0	239	22	2188	19	0	2229	4646
Apprch %	12.8	2.8	84.3	0		4.5	85.1	10.3	0		70.7	5.4	23.8	0		1	98.2	0.9	0		
Total %	1	0.2	6.4	0	7.6	1.8	33.5	4.1	0	39.3	3.6	0.3	1.2	0	5.1	0.5	47.1	0.4	0	48	

Start Time	HOSPITAL PZ Southbound					WILLOW RD Westbound					DURHAM ST Northbound					WILLOW RD Eastbound					Int. Total
	Right	Thru	Left	Peds	App. Total	Right	Thru	Left	Peds	App. Total	Right	Thru	Left	Peds	App. Total	Right	Thru	Left	Peds	App. Total	
Peak Hour Analysis From 04:00 PM to 05:45 PM - Peak 1 of 1																					
Peak Hour for Entire Intersection Begins at 04:45 PM																					
04:45 PM	7	1	28	0	36	17	185	24	0	226	20	1	12	0	33	2	281	2	0	285	580
05:00 PM	9	1	35	0	45	16	206	25	0	247	23	2	9	0	34	5	291	0	0	296	622
05:15 PM	9	0	30	0	39	5	187	19	0	211	28	2	9	0	39	0	277	3	0	280	569
05:30 PM	6	3	29	0	38	13	240	22	0	275	14	2	3	0	19	3	276	6	0	285	617
Total Volume	31	5	122	0	158	51	818	90	0	959	85	7	33	0	125	10	1125	11	0	1146	2388
% App. Total																					
PHF	.861	.417	.871	.000	.878	.750	.852	.900	.000	.872	.759	.875	.688	.000	.801	.500	.966	.458	.000	.968	.960

# Traffic Data Service

Campbell, CA  
 (408) 377-2988  
 tdsbay@cs.com

File Name : 20PM FINAL  
 Site Code : 00000020  
 Start Date : 11/16/2010  
 Page No : 2

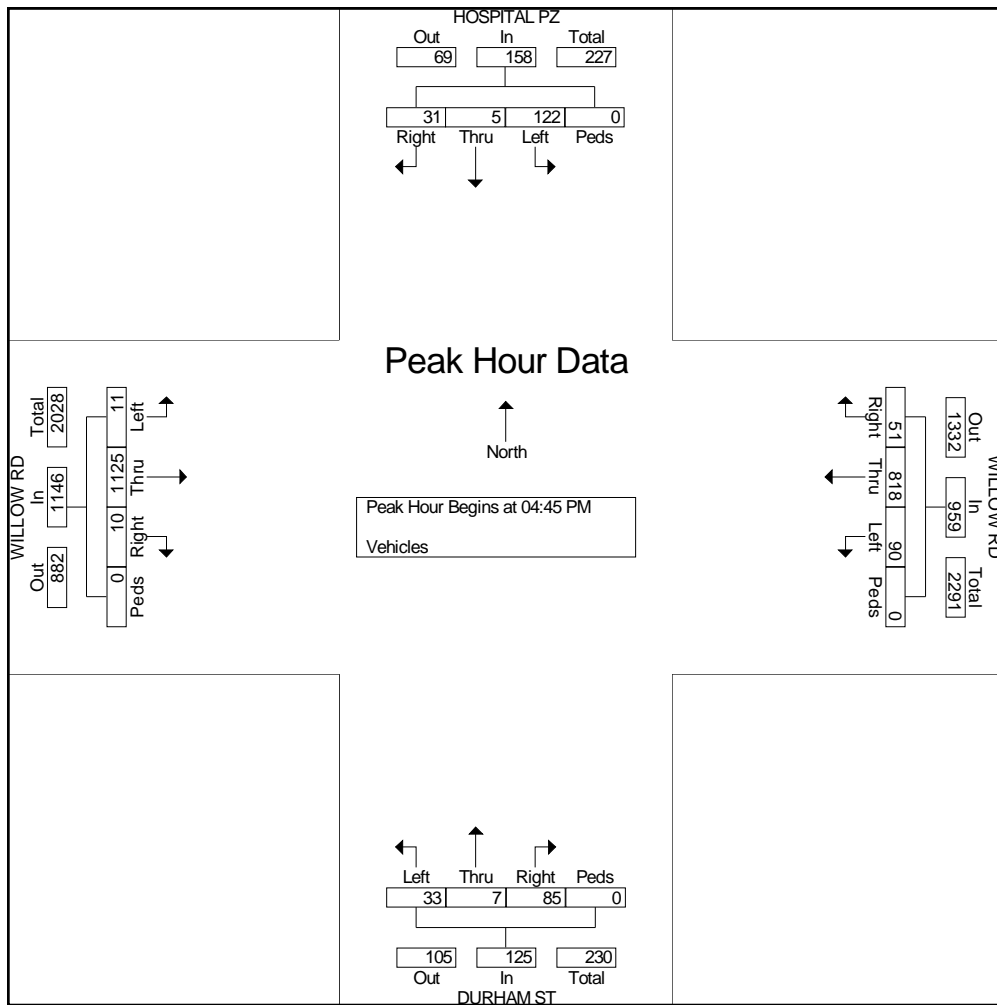

# Traffic Data Service

Campbell, CA  
(408) 377-2988  
tdsbay@cs.com

File Name : 21AM FINAL  
Site Code : 00000021  
Start Date : 11/10/2010  
Page No : 1

### Groups Printed- Vehicles

Start Time	COLEMAN AVE Southbound					WILLOW RD Westbound					COLEMAN AVE Northbound					WILLOW RD Eastbound					Int. Total
	Right	Thru	Left	Peds	App. Total	Right	Thru	Left	Peds	App. Total	Right	Thru	Left	Peds	App. Total	Right	Thru	Left	Peds	App. Total	
07:00 AM	3	0	23	0	26	15	221	1	0	237	1	0	0	0	1	0	137	2	0	139	403
07:15 AM	4	0	31	0	35	10	239	3	0	252	0	0	1	0	1	1	163	3	0	167	455
07:30 AM	9	0	37	0	46	10	205	1	0	216	2	0	0	0	2	0	195	0	0	195	459
07:45 AM	6	0	31	0	37	14	227	4	0	245	2	1	1	0	4	3	236	3	0	242	528
<b>Total</b>	<b>22</b>	<b>0</b>	<b>122</b>	<b>0</b>	<b>144</b>	<b>49</b>	<b>892</b>	<b>9</b>	<b>0</b>	<b>950</b>	<b>5</b>	<b>1</b>	<b>2</b>	<b>0</b>	<b>8</b>	<b>4</b>	<b>731</b>	<b>8</b>	<b>0</b>	<b>743</b>	<b>1845</b>
08:00 AM	5	0	42	0	47	26	192	0	0	218	0	0	0	0	0	1	238	8	0	247	512
08:15 AM	25	5	34	0	64	10	192	1	0	203	2	0	2	0	4	1	221	6	0	228	499
08:30 AM	12	1	35	0	48	12	243	1	0	256	4	2	0	0	6	0	197	0	0	197	507
08:45 AM	7	0	46	0	53	14	227	1	0	242	1	0	2	0	3	0	191	5	0	196	494
<b>Total</b>	<b>49</b>	<b>6</b>	<b>157</b>	<b>0</b>	<b>212</b>	<b>62</b>	<b>854</b>	<b>3</b>	<b>0</b>	<b>919</b>	<b>7</b>	<b>2</b>	<b>4</b>	<b>0</b>	<b>13</b>	<b>2</b>	<b>847</b>	<b>19</b>	<b>0</b>	<b>868</b>	<b>2012</b>
<b>Grand Total</b>	<b>71</b>	<b>6</b>	<b>279</b>	<b>0</b>	<b>356</b>	<b>111</b>	<b>1746</b>	<b>12</b>	<b>0</b>	<b>1869</b>	<b>12</b>	<b>3</b>	<b>6</b>	<b>0</b>	<b>21</b>	<b>6</b>	<b>1578</b>	<b>27</b>	<b>0</b>	<b>1611</b>	<b>3857</b>
<b>Apprch %</b>	<b>19.9</b>	<b>1.7</b>	<b>78.4</b>	<b>0</b>		<b>5.9</b>	<b>93.4</b>	<b>0.6</b>	<b>0</b>		<b>57.1</b>	<b>14.3</b>	<b>28.6</b>	<b>0</b>		<b>0.4</b>	<b>98</b>	<b>1.7</b>	<b>0</b>		
<b>Total %</b>	<b>1.8</b>	<b>0.2</b>	<b>7.2</b>	<b>0</b>	<b>9.2</b>	<b>2.9</b>	<b>45.3</b>	<b>0.3</b>	<b>0</b>	<b>48.5</b>	<b>0.3</b>	<b>0.1</b>	<b>0.2</b>	<b>0</b>	<b>0.5</b>	<b>0.2</b>	<b>40.9</b>	<b>0.7</b>	<b>0</b>	<b>41.8</b>	

Start Time	COLEMAN AVE Southbound					WILLOW RD Westbound					COLEMAN AVE Northbound					WILLOW RD Eastbound					Int. Total
	Right	Thru	Left	Peds	App. Total	Right	Thru	Left	Peds	App. Total	Right	Thru	Left	Peds	App. Total	Right	Thru	Left	Peds	App. Total	
Peak Hour Analysis From 07:00 AM to 08:45 AM - Peak 1 of 1																					
Peak Hour for Entire Intersection Begins at 07:45 AM																					
07:45 AM	6	0	31	0	37	14	227	4	0	245	2	1	1	0	4	3	236	3	0	242	528
08:00 AM	5	0	42	0	47	26	192	0	0	218	0	0	0	0	0	1	238	8	0	247	512
08:15 AM	25	5	34	0	64	10	192	1	0	203	2	0	2	0	4	1	221	6	0	228	499
08:30 AM	12	1	35	0	48	12	243	1	0	256	4	2	0	0	6	0	197	0	0	197	507
<b>Total Volume</b>	<b>48</b>	<b>6</b>	<b>142</b>	<b>0</b>	<b>196</b>	<b>62</b>	<b>854</b>	<b>6</b>	<b>0</b>	<b>922</b>	<b>8</b>	<b>3</b>	<b>3</b>	<b>0</b>	<b>14</b>	<b>5</b>	<b>892</b>	<b>17</b>	<b>0</b>	<b>914</b>	<b>2046</b>
<b>% App. Total</b>	<b>24.5</b>	<b>3.1</b>	<b>72.4</b>	<b>0</b>		<b>6.7</b>	<b>92.6</b>	<b>0.7</b>	<b>0</b>		<b>57.1</b>	<b>21.4</b>	<b>21.4</b>	<b>0</b>		<b>0.5</b>	<b>97.6</b>	<b>1.9</b>	<b>0</b>		
<b>PHF</b>	<b>.480</b>	<b>.300</b>	<b>.845</b>	<b>.000</b>	<b>.766</b>	<b>.596</b>	<b>.879</b>	<b>.375</b>	<b>.000</b>	<b>.900</b>	<b>.500</b>	<b>.375</b>	<b>.375</b>	<b>.000</b>	<b>.583</b>	<b>.417</b>	<b>.937</b>	<b>.531</b>	<b>.000</b>	<b>.925</b>	<b>.969</b>

# Traffic Data Service

Campbell, CA  
 (408) 377-2988  
 tdsbay@cs.com

File Name : 21AM FINAL  
 Site Code : 00000021  
 Start Date : 11/10/2010  
 Page No : 2

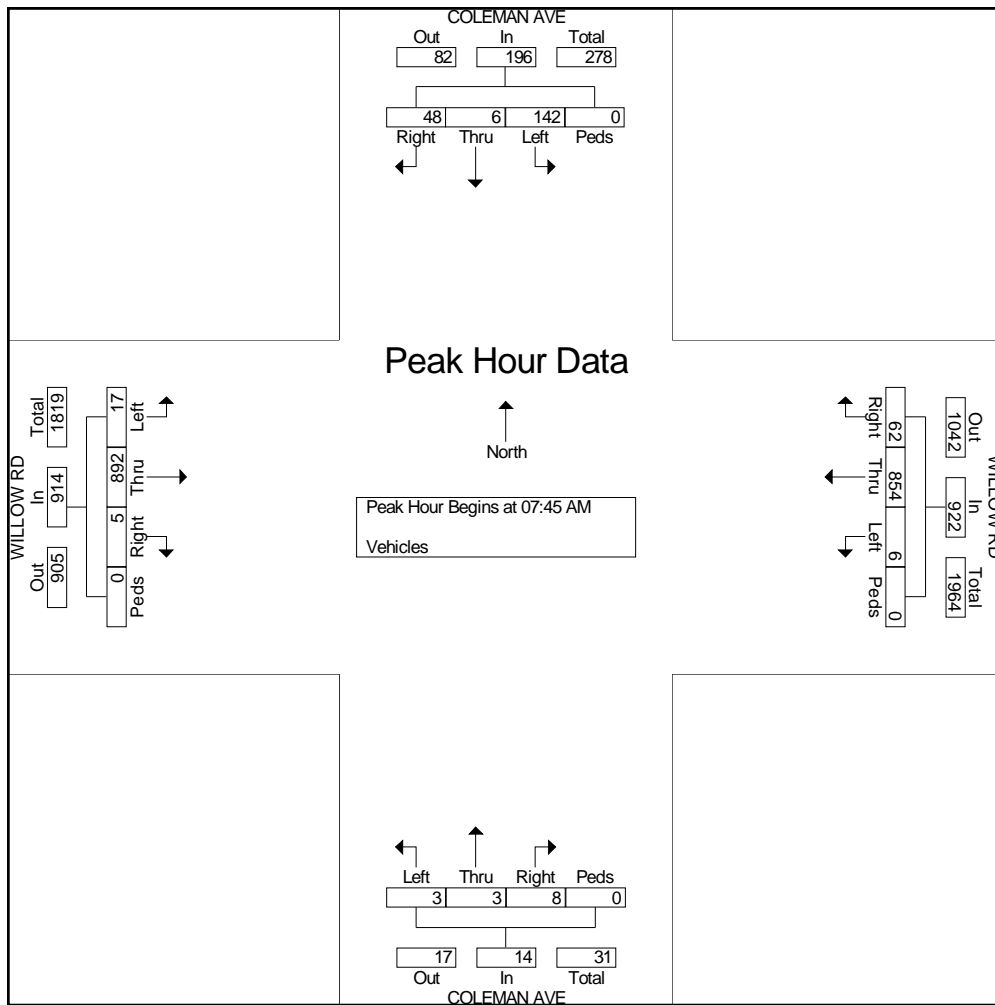

# Traffic Data Service

Campbell, CA  
(408) 377-2988  
tdsbay@cs.com

File Name : 21PM FINAL  
Site Code : 00000021  
Start Date : 11/10/2010  
Page No : 1

### Groups Printed- Vehicles

Start Time	COLEMAN AVE Southbound					WILLOW RD Westbound					COLEMAN AVE Northbound					WILLOW RD Eastbound					Int. Total
	Right	Thru	Left	Peds	App. Total	Right	Thru	Left	Peds	App. Total	Right	Thru	Left	Peds	App. Total	Right	Thru	Left	Peds	App. Total	
04:00 PM	9	2	24	0	35	19	166	5	0	190	4	4	5	0	13	5	260	2	0	267	505
04:15 PM	5	3	20	0	28	16	152	5	0	173	4	3	1	0	8	0	253	4	0	257	466
04:30 PM	6	0	18	0	24	14	166	1	0	181	0	2	0	0	2	0	263	5	0	268	475
04:45 PM	6	1	19	0	26	17	203	2	0	222	2	0	1	0	3	2	274	0	0	276	527
<b>Total</b>	<b>26</b>	<b>6</b>	<b>81</b>	<b>0</b>	<b>113</b>	<b>66</b>	<b>687</b>	<b>13</b>	<b>0</b>	<b>766</b>	<b>10</b>	<b>9</b>	<b>7</b>	<b>0</b>	<b>26</b>	<b>7</b>	<b>1050</b>	<b>11</b>	<b>0</b>	<b>1068</b>	<b>1973</b>
05:00 PM	8	2	28	0	38	21	188	2	0	211	2	1	1	0	4	2	279	6	0	287	540
05:15 PM	5	2	17	0	24	23	202	2	0	227	2	4	3	0	9	2	255	5	0	262	522
05:30 PM	11	2	25	0	38	30	202	1	0	233	2	4	8	0	14	2	274	6	0	282	567
05:45 PM	11	0	22	0	33	35	203	0	0	238	1	2	0	0	3	0	275	7	0	282	556
<b>Total</b>	<b>35</b>	<b>6</b>	<b>92</b>	<b>0</b>	<b>133</b>	<b>109</b>	<b>795</b>	<b>5</b>	<b>0</b>	<b>909</b>	<b>7</b>	<b>11</b>	<b>12</b>	<b>0</b>	<b>30</b>	<b>6</b>	<b>1083</b>	<b>24</b>	<b>0</b>	<b>1113</b>	<b>2185</b>
Grand Total	61	12	173	0	246	175	1482	18	0	1675	17	20	19	0	56	13	2133	35	0	2181	4158
Apprch %	24.8	4.9	70.3	0		10.4	88.5	1.1	0		30.4	35.7	33.9	0		0.6	97.8	1.6	0		
Total %	1.5	0.3	4.2	0	5.9	4.2	35.6	0.4	0	40.3	0.4	0.5	0.5	0	1.3	0.3	51.3	0.8	0	52.5	

Start Time	COLEMAN AVE Southbound					WILLOW RD Westbound					COLEMAN AVE Northbound					WILLOW RD Eastbound					Int. Total
	Right	Thru	Left	Peds	App. Total	Right	Thru	Left	Peds	App. Total	Right	Thru	Left	Peds	App. Total	Right	Thru	Left	Peds	App. Total	
Peak Hour Analysis From 04:00 PM to 05:45 PM - Peak 1 of 1																					
Peak Hour for Entire Intersection Begins at 05:00 PM																					
05:00 PM	8	2	28	0	38	21	188	2	0	211	2	1	1	0	4	2	279	6	0	287	540
05:15 PM	5	2	17	0	24	23	202	2	0	227	2	4	3	0	9	2	255	5	0	262	522
05:30 PM	11	2	25	0	38	30	202	1	0	233	2	4	8	0	14	2	274	6	0	282	567
05:45 PM	11	0	22	0	33	35	203	0	0	238	1	2	0	0	3	0	275	7	0	282	556
Total Volume	35	6	92	0	133	109	795	5	0	909	7	11	12	0	30	6	1083	24	0	1113	2185
% App. Total																					
PHF	.795	.750	.821	.000	.875	.779	.979	.625	.000	.955	.875	.688	.375	.000	.536	.750	.970	.857	.000	.970	.963



# Traffic Data Service

Campbell, CA  
 (408) 377-2988  
 tdsbay@cs.com

File Name : 21PM FINAL  
 Site Code : 00000021  
 Start Date : 11/10/2010  
 Page No : 2

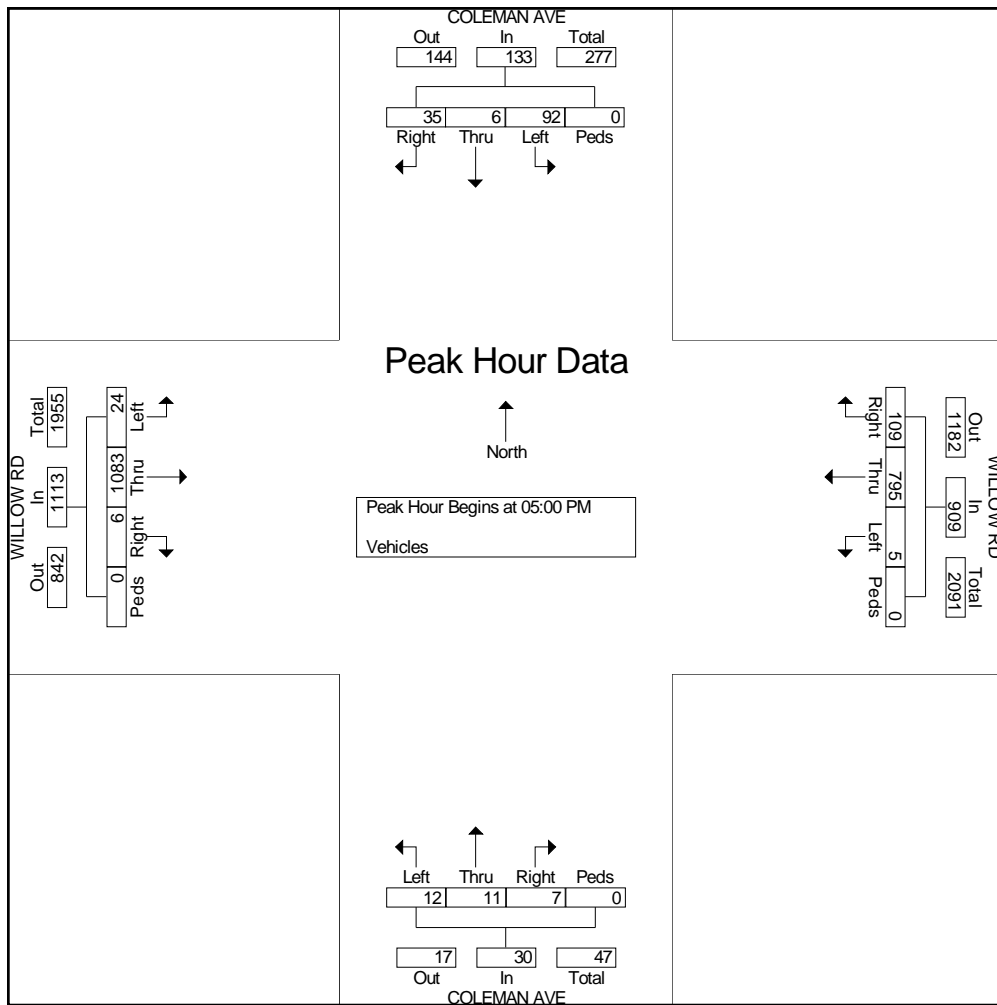

# Traffic Data Service

Campbell, CA  
(408) 377-2988  
tdsbay@cs.com

File Name : 22AM FINAL  
Site Code : 00000022  
Start Date : 11/10/2010  
Page No : 1

### Groups Printed- Vehicles

Start Time	GILBERT AVE Southbound					WILLOW RD Westbound					GILBERT AVE Northbound					WILLOW RD Eastbound					Int. Total
	Right	Thru	Left	Peds	App. Total	Right	Thru	Left	Peds	App. Total	Right	Thru	Left	Peds	App. Total	Right	Thru	Left	Peds	App. Total	
07:00 AM	2	1	8	0	11	3	220	4	0	227	14	0	12	0	26	4	121	1	0	126	390
07:15 AM	0	1	3	0	4	2	237	10	0	249	20	5	15	0	40	8	135	0	0	143	436
07:30 AM	3	2	6	0	11	2	204	6	0	212	23	7	22	0	52	13	179	1	0	193	468
07:45 AM	3	5	4	0	12	1	227	12	0	240	29	15	35	0	79	14	220	0	0	234	565
<b>Total</b>	<b>8</b>	<b>9</b>	<b>21</b>	<b>0</b>	<b>38</b>	<b>8</b>	<b>888</b>	<b>32</b>	<b>0</b>	<b>928</b>	<b>86</b>	<b>27</b>	<b>84</b>	<b>0</b>	<b>197</b>	<b>39</b>	<b>655</b>	<b>2</b>	<b>0</b>	<b>696</b>	<b>1859</b>
08:00 AM	0	14	6	0	20	2	187	13	0	202	45	43	23	0	111	28	208	2	0	238	571
08:15 AM	2	17	12	0	31	1	208	11	0	220	19	13	19	0	51	20	191	2	0	213	515
08:30 AM	2	5	9	0	16	1	247	5	0	253	29	14	24	0	67	10	175	0	0	185	521
08:45 AM	3	9	5	0	17	0	260	5	0	265	19	13	25	0	57	14	175	1	0	190	529
<b>Total</b>	<b>7</b>	<b>45</b>	<b>32</b>	<b>0</b>	<b>84</b>	<b>4</b>	<b>902</b>	<b>34</b>	<b>0</b>	<b>940</b>	<b>112</b>	<b>83</b>	<b>91</b>	<b>0</b>	<b>286</b>	<b>72</b>	<b>749</b>	<b>5</b>	<b>0</b>	<b>826</b>	<b>2136</b>
<b>Grand Total</b>	<b>15</b>	<b>54</b>	<b>53</b>	<b>0</b>	<b>122</b>	<b>12</b>	<b>1790</b>	<b>66</b>	<b>0</b>	<b>1868</b>	<b>198</b>	<b>110</b>	<b>175</b>	<b>0</b>	<b>483</b>	<b>111</b>	<b>1404</b>	<b>7</b>	<b>0</b>	<b>1522</b>	<b>3995</b>
<b>Apprch %</b>	<b>12.3</b>	<b>44.3</b>	<b>43.4</b>	<b>0</b>		<b>0.6</b>	<b>95.8</b>	<b>3.5</b>	<b>0</b>		<b>41</b>	<b>22.8</b>	<b>36.2</b>	<b>0</b>		<b>7.3</b>	<b>92.2</b>	<b>0.5</b>	<b>0</b>		
<b>Total %</b>	<b>0.4</b>	<b>1.4</b>	<b>1.3</b>	<b>0</b>	<b>3.1</b>	<b>0.3</b>	<b>44.8</b>	<b>1.7</b>	<b>0</b>	<b>46.8</b>	<b>5</b>	<b>2.8</b>	<b>4.4</b>	<b>0</b>	<b>12.1</b>	<b>2.8</b>	<b>35.1</b>	<b>0.2</b>	<b>0</b>	<b>38.1</b>	

Start Time	GILBERT AVE Southbound					WILLOW RD Westbound					GILBERT AVE Northbound					WILLOW RD Eastbound					Int. Total
	Right	Thru	Left	Peds	App. Total	Right	Thru	Left	Peds	App. Total	Right	Thru	Left	Peds	App. Total	Right	Thru	Left	Peds	App. Total	
Peak Hour Analysis From 07:00 AM to 08:45 AM - Peak 1 of 1																					
Peak Hour for Entire Intersection Begins at 07:45 AM																					
07:45 AM	3	5	4	0	12	1	227	12	0	240	29	15	35	0	79	14	220	0	0	234	565
08:00 AM	0	14	6	0	20	2	187	13	0	202	45	43	23	0	111	28	208	2	0	238	571
08:15 AM	2	17	12	0	31	1	208	11	0	220	19	13	19	0	51	20	191	2	0	213	515
08:30 AM	2	5	9	0	16	1	247	5	0	253	29	14	24	0	67	10	175	0	0	185	521
<b>Total Volume</b>	<b>7</b>	<b>41</b>	<b>31</b>	<b>0</b>	<b>79</b>	<b>5</b>	<b>869</b>	<b>41</b>	<b>0</b>	<b>915</b>	<b>122</b>	<b>85</b>	<b>101</b>	<b>0</b>	<b>308</b>	<b>72</b>	<b>794</b>	<b>4</b>	<b>0</b>	<b>870</b>	<b>2172</b>
<b>% App. Total</b>	<b>8.9</b>	<b>51.9</b>	<b>39.2</b>	<b>0</b>		<b>0.5</b>	<b>95</b>	<b>4.5</b>	<b>0</b>		<b>39.6</b>	<b>27.6</b>	<b>32.8</b>	<b>0</b>		<b>8.3</b>	<b>91.3</b>	<b>0.5</b>	<b>0</b>		
<b>PHF</b>	<b>.583</b>	<b>.603</b>	<b>.646</b>	<b>.000</b>	<b>.637</b>	<b>.625</b>	<b>.880</b>	<b>.788</b>	<b>.000</b>	<b>.904</b>	<b>.678</b>	<b>.494</b>	<b>.721</b>	<b>.000</b>	<b>.694</b>	<b>.643</b>	<b>.902</b>	<b>.500</b>	<b>.000</b>	<b>.914</b>	<b>.951</b>

# Traffic Data Service

Campbell, CA  
 (408) 377-2988  
 tdsbay@cs.com

File Name : 22AM FINAL  
 Site Code : 00000022  
 Start Date : 11/10/2010  
 Page No : 2

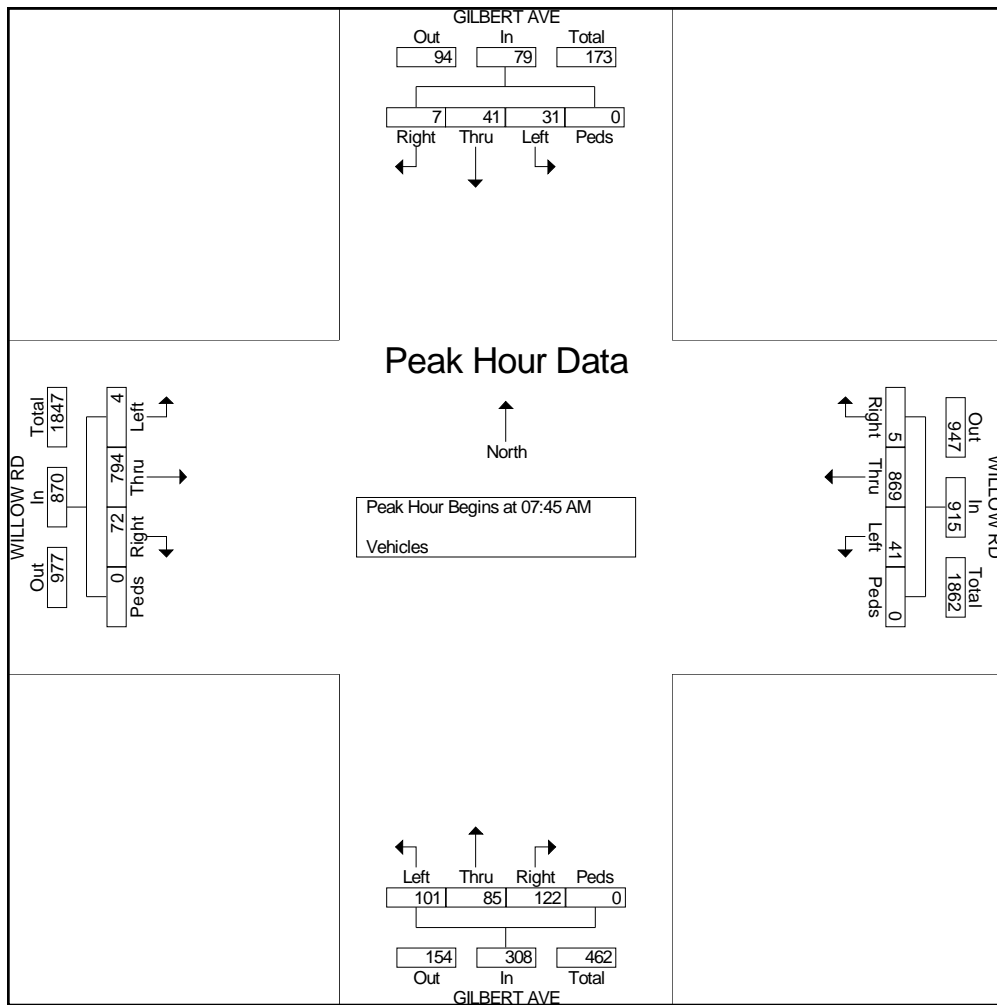

# Traffic Data Service

Campbell, CA  
(408) 377-2988  
tdsbay@cs.com

File Name : 22PM FINAL  
Site Code : 00000022  
Start Date : 11/10/2010  
Page No : 1

### Groups Printed- Vehicles

Start Time	GILBERT AVE Southbound					WILLOW RD Westbound					GILBERT AVE Northbound					WILLOW RD Eastbound					Int. Total
	Right	Thru	Left	Peds	App. Total	Right	Thru	Left	Peds	App. Total	Right	Thru	Left	Peds	App. Total	Right	Thru	Left	Peds	App. Total	
04:00 PM	0	1	5	0	6	5	172	13	0	190	11	10	18	0	39	16	253	1	0	270	505
04:15 PM	2	4	4	0	10	1	155	9	0	165	19	6	16	0	41	18	230	0	0	248	464
04:30 PM	1	5	7	0	13	5	147	12	0	164	17	5	33	0	55	8	237	1	0	246	478
04:45 PM	1	2	6	0	9	1	196	12	0	209	17	4	16	0	37	10	256	1	0	267	522
<b>Total</b>	<b>4</b>	<b>12</b>	<b>22</b>	<b>0</b>	<b>38</b>	<b>12</b>	<b>670</b>	<b>46</b>	<b>0</b>	<b>728</b>	<b>64</b>	<b>25</b>	<b>83</b>	<b>0</b>	<b>172</b>	<b>52</b>	<b>976</b>	<b>3</b>	<b>0</b>	<b>1031</b>	<b>1969</b>
05:00 PM	1	6	9	0	16	3	198	10	0	211	16	5	18	0	39	12	232	1	0	245	511
05:15 PM	1	7	6	0	14	6	182	8	0	196	23	11	22	0	56	5	232	0	0	237	503
05:30 PM	1	11	10	0	22	2	238	9	0	249	16	7	26	0	49	7	255	1	0	263	583
05:45 PM	1	6	4	0	11	6	214	10	0	230	20	8	26	0	54	12	250	2	0	264	559
<b>Total</b>	<b>4</b>	<b>30</b>	<b>29</b>	<b>0</b>	<b>63</b>	<b>17</b>	<b>832</b>	<b>37</b>	<b>0</b>	<b>886</b>	<b>75</b>	<b>31</b>	<b>92</b>	<b>0</b>	<b>198</b>	<b>36</b>	<b>969</b>	<b>4</b>	<b>0</b>	<b>1009</b>	<b>2156</b>
<b>Grand Total</b>	<b>8</b>	<b>42</b>	<b>51</b>	<b>0</b>	<b>101</b>	<b>29</b>	<b>1502</b>	<b>83</b>	<b>0</b>	<b>1614</b>	<b>139</b>	<b>56</b>	<b>175</b>	<b>0</b>	<b>370</b>	<b>88</b>	<b>1945</b>	<b>7</b>	<b>0</b>	<b>2040</b>	<b>4125</b>
Apprch %	7.9	41.6	50.5	0		1.8	93.1	5.1	0		37.6	15.1	47.3	0		4.3	95.3	0.3	0		
Total %	0.2	1	1.2	0	2.4	0.7	36.4	2	0	39.1	3.4	1.4	4.2	0	9	2.1	47.2	0.2	0	49.5	

Start Time	GILBERT AVE Southbound					WILLOW RD Westbound					GILBERT AVE Northbound					WILLOW RD Eastbound					Int. Total
	Right	Thru	Left	Peds	App. Total	Right	Thru	Left	Peds	App. Total	Right	Thru	Left	Peds	App. Total	Right	Thru	Left	Peds	App. Total	
Peak Hour Analysis From 04:00 PM to 05:45 PM - Peak 1 of 1																					
Peak Hour for Entire Intersection Begins at 05:00 PM																					
05:00 PM	1	6	9	0	16	3	198	10	0	211	16	5	18	0	39	12	232	1	0	245	511
05:15 PM	1	7	6	0	14	6	182	8	0	196	23	11	22	0	56	5	232	0	0	237	503
05:30 PM	1	11	10	0	22	2	238	9	0	249	16	7	26	0	49	7	255	1	0	263	583
05:45 PM	1	6	4	0	11	6	214	10	0	230	20	8	26	0	54	12	250	2	0	264	559
<b>Total Volume</b>	<b>4</b>	<b>30</b>	<b>29</b>	<b>0</b>	<b>63</b>	<b>17</b>	<b>832</b>	<b>37</b>	<b>0</b>	<b>886</b>	<b>75</b>	<b>31</b>	<b>92</b>	<b>0</b>	<b>198</b>	<b>36</b>	<b>969</b>	<b>4</b>	<b>0</b>	<b>1009</b>	<b>2156</b>
<b>% App. Total</b>	<b>6.3</b>	<b>47.6</b>	<b>46</b>	<b>0</b>		<b>1.9</b>	<b>93.9</b>	<b>4.2</b>	<b>0</b>		<b>37.9</b>	<b>15.7</b>	<b>46.5</b>	<b>0</b>		<b>3.6</b>	<b>96</b>	<b>0.4</b>	<b>0</b>		
<b>PHF</b>	<b>1.000</b>	<b>.682</b>	<b>.725</b>	<b>.000</b>	<b>.716</b>	<b>.708</b>	<b>.874</b>	<b>.925</b>	<b>.000</b>	<b>.890</b>	<b>.815</b>	<b>.705</b>	<b>.885</b>	<b>.000</b>	<b>.884</b>	<b>.750</b>	<b>.950</b>	<b>.500</b>	<b>.000</b>	<b>.955</b>	<b>.925</b>

# Traffic Data Service

Campbell, CA  
 (408) 377-2988  
 tdsbay@cs.com

File Name : 22PM FINAL  
 Site Code : 00000022  
 Start Date : 11/10/2010  
 Page No : 2

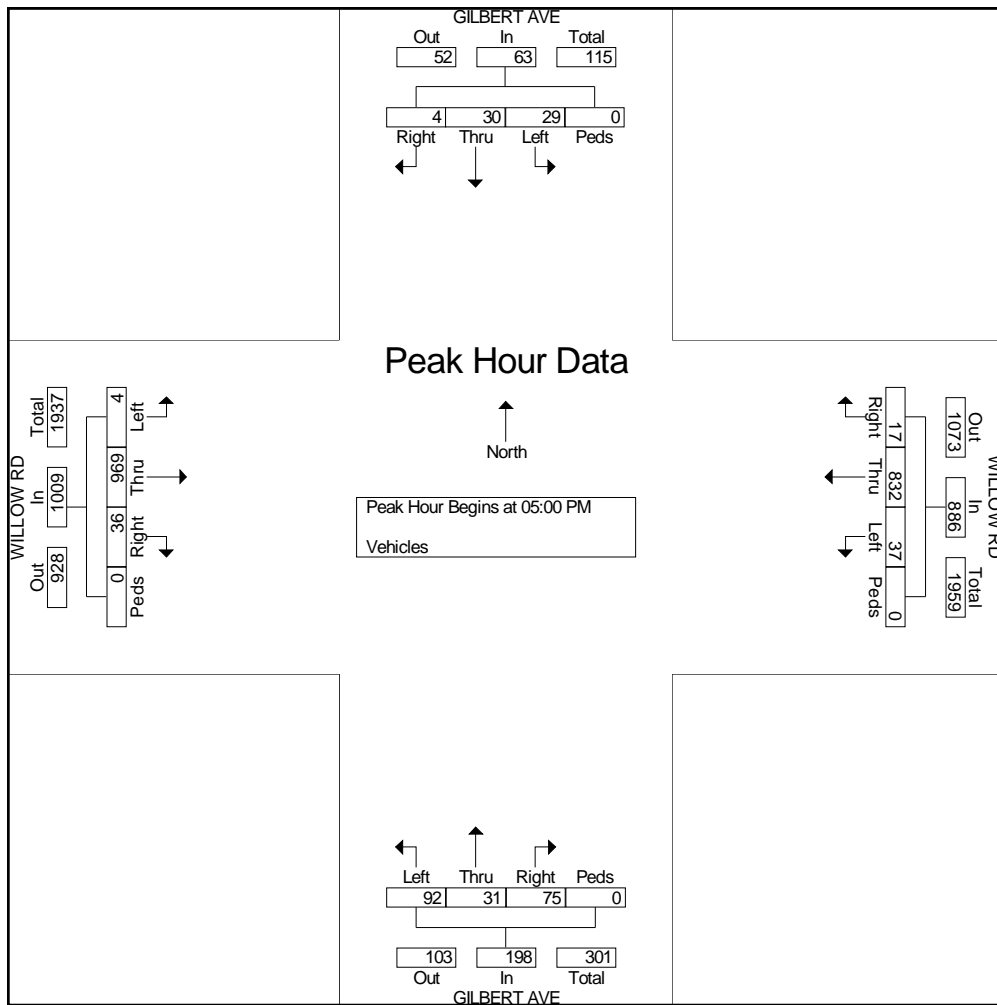

# Traffic Data Service

Campbell, CA  
(408) 377-2988  
tdsbay@cs.com

File Name : 10AM FINAL  
Site Code : 00000010  
Start Date : 11/10/2010  
Page No : 1

### Groups Printed- Vehicles

Start Time	MIDDLEFIELD RD Southbound					WILLOW RD Westbound					MIDDLEFIELD RD Northbound					WILLOW RD Eastbound					Int. Total
	Right	Thru	Left	Peds	App. Total	Right	Thru	Left	Peds	App. Total	Right	Thru	Left	Peds	App. Total	Right	Thru	Left	Peds	App. Total	
07:00 AM	0	30	55	0	85	123	11	79	0	213	43	25	7	0	75	13	26	1	0	40	413
07:15 AM	1	43	60	0	104	121	15	106	0	242	53	54	13	0	120	15	32	2	0	49	515
07:30 AM	5	40	85	0	130	132	15	86	0	233	62	82	10	0	154	17	43	2	0	62	579
07:45 AM	3	69	100	0	172	143	15	104	0	262	66	69	11	0	146	26	40	7	0	73	653
<b>Total</b>	<b>9</b>	<b>182</b>	<b>300</b>	<b>0</b>	<b>491</b>	<b>519</b>	<b>56</b>	<b>375</b>	<b>0</b>	<b>950</b>	<b>224</b>	<b>230</b>	<b>41</b>	<b>0</b>	<b>495</b>	<b>71</b>	<b>141</b>	<b>12</b>	<b>0</b>	<b>224</b>	<b>2160</b>
08:00 AM	1	81	117	0	199	125	17	82	0	224	68	84	24	0	176	26	51	1	0	78	677
08:15 AM	3	84	100	0	187	106	15	111	0	232	59	96	19	0	174	38	41	2	0	81	674
08:30 AM	3	88	91	0	182	120	17	123	0	260	52	93	13	0	158	27	34	6	0	67	667
08:45 AM	5	91	87	0	183	119	19	110	0	248	44	84	20	0	148	30	35	2	0	67	646
<b>Total</b>	<b>12</b>	<b>344</b>	<b>395</b>	<b>0</b>	<b>751</b>	<b>470</b>	<b>68</b>	<b>426</b>	<b>0</b>	<b>964</b>	<b>223</b>	<b>357</b>	<b>76</b>	<b>0</b>	<b>656</b>	<b>121</b>	<b>161</b>	<b>11</b>	<b>0</b>	<b>293</b>	<b>2664</b>
<b>Grand Total</b>	<b>21</b>	<b>526</b>	<b>695</b>	<b>0</b>	<b>1242</b>	<b>989</b>	<b>124</b>	<b>801</b>	<b>0</b>	<b>1914</b>	<b>447</b>	<b>587</b>	<b>117</b>	<b>0</b>	<b>1151</b>	<b>192</b>	<b>302</b>	<b>23</b>	<b>0</b>	<b>517</b>	<b>4824</b>
Apprch %	1.7	42.4	56	0		51.7	6.5	41.8	0		38.8	51	10.2	0		37.1	58.4	4.4	0		
Total %	0.4	10.9	14.4	0	25.7	20.5	2.6	16.6	0	39.7	9.3	12.2	2.4	0	23.9	4	6.3	0.5	0	10.7	

Start Time	MIDDLEFIELD RD Southbound					WILLOW RD Westbound					MIDDLEFIELD RD Northbound					WILLOW RD Eastbound					Int. Total
	Right	Thru	Left	Peds	App. Total	Right	Thru	Left	Peds	App. Total	Right	Thru	Left	Peds	App. Total	Right	Thru	Left	Peds	App. Total	
Peak Hour Analysis From 07:00 AM to 08:45 AM - Peak 1 of 1																					
Peak Hour for Entire Intersection Begins at 07:45 AM																					
07:45 AM	3	69	100	0	172	143	15	104	0	262	66	69	11	0	146	26	40	7	0	73	653
08:00 AM	1	81	117	0	199	125	17	82	0	224	68	84	24	0	176	26	51	1	0	78	677
08:15 AM	3	84	100	0	187	106	15	111	0	232	59	96	19	0	174	38	41	2	0	81	674
08:30 AM	3	88	91	0	182	120	17	123	0	260	52	93	13	0	158	27	34	6	0	67	667
Total Volume	10	322	408	0	740	494	64	420	0	978	245	342	67	0	654	117	166	16	0	299	2671
% App. Total	1.4	43.5	55.1	0		50.5	6.5	42.9	0		37.5	52.3	10.2	0		39.1	55.5	5.4	0		
PHF	.833	.915	.872	.000	.930	.864	.941	.854	.000	.933	.901	.891	.698	.000	.929	.770	.814	.571	.000	.923	.986

# Traffic Data Service

Campbell, CA  
 (408) 377-2988  
 tdsbay@cs.com

File Name : 10AM FINAL  
 Site Code : 00000010  
 Start Date : 11/10/2010  
 Page No : 2

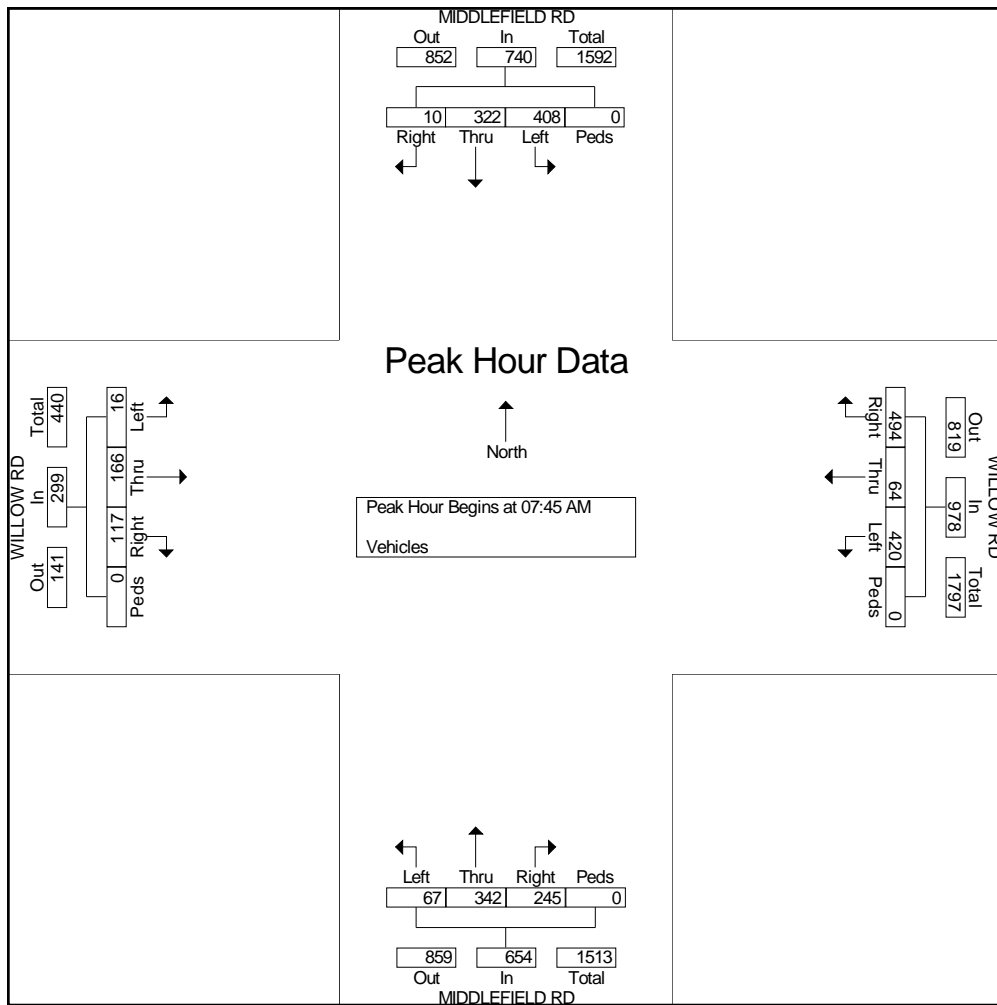

# All Traffic Data

(916) 771-8700

CITY OF MENLOW PARK

File Name : 11-7184-001 WILLOW-MIDDLEFIELD

Site Code : 00000000

Start Date : 5/3/2011

Page No : 1

## Groups Printed- Unshifted

Start Time	WILLOW RD. Southbound				MIDDLEFIELD RD. Westbound				WILLOW RD. Northbound				MIDDLEFIELD RD. Eastbound				Int. Total
	Left	Thru	Right	App. Total	Left	Thru	Right	App. Total	Left	Thru	Right	App. Total	Left	Thru	Right	App. Total	
08:30	91	16	97	204	18	83	50	151	5	42	17	64	97	93	0	190	609
08:45	88	19	65	172	11	83	56	150	4	22	24	50	90	121	3	214	586
Total	179	35	162	376	29	166	106	301	9	64	41	114	187	214	3	404	1195
09:00	79	16	54	149	15	77	61	153	3	25	20	48	81	111	6	198	548
09:15	97	11	66	174	19	64	44	127	3	27	12	42	70	79	6	155	498
09:30	106	16	88	210	17	57	47	121	3	22	10	35	61	75	1	137	503
09:45	84	19	68	171	10	76	42	128	6	23	17	46	100	83	2	185	530
Total	366	62	276	704	61	274	194	529	15	97	59	171	312	348	15	675	2079
10:00	104	18	57	179	14	54	41	109	5	28	12	45	82	64	7	153	486
10:15	87	13	71	171	17	56	51	124	1	28	16	45	57	79	3	139	479
Grand Total	736	128	566	1430	121	550	392	1063	30	217	128	375	638	705	28	1371	4239
Apprch %	51.5	9	39.6		11.4	51.7	36.9		8	57.9	34.1		46.5	51.4	2		
Total %	17.4	3	13.4	33.7	2.9	13	9.2	25.1	0.7	5.1	3	8.8	15.1	16.6	0.7	32.3	

Start Time	WILLOW RD. Southbound				MIDDLEFIELD RD. Westbound				WILLOW RD. Northbound				MIDDLEFIELD RD. Eastbound				Int. Total
	Left	Thru	Right	App. Total	Left	Thru	Right	App. Total	Left	Thru	Right	App. Total	Left	Thru	Right	App. Total	
Peak Hour Analysis From 08:30 to 10:15 - Peak 1 of 1																	
Peak Hour for Entire Intersection Begins at 08:30																	
08:30	91	16	<b>97</b>	<b>204</b>	18	<b>83</b>	50	151	<b>5</b>	<b>42</b>	17	<b>64</b>	<b>97</b>	93	0	190	<b>609</b>
08:45	88	<b>19</b>	65	172	11	83	56	150	4	22	<b>24</b>	50	90	<b>121</b>	3	<b>214</b>	586
09:00	79	16	54	149	15	77	<b>61</b>	<b>153</b>	3	25	20	48	81	111	<b>6</b>	198	548
09:15	<b>97</b>	11	66	174	<b>19</b>	64	44	127	3	27	12	42	70	79	6	155	498
Total Volume	355	62	282	699	63	307	211	581	15	116	73	204	338	404	15	757	2241
% App. Total	50.8	8.9	40.3		10.8	52.8	36.3		7.4	56.9	35.8		44.6	53.4	2		
PHF	.915	.816	.727	.857	.829	.925	.865	.949	.750	.690	.760	.797	.871	.835	.625	.884	.920



# All Traffic Data

(916) 771-8700

CITY OF MENLOW PARK

File Name : 11-7184-001 WILLOW-MIDDLEFIELD

Site Code : 00000000

Start Date : 5/3/2011

Page No : 2

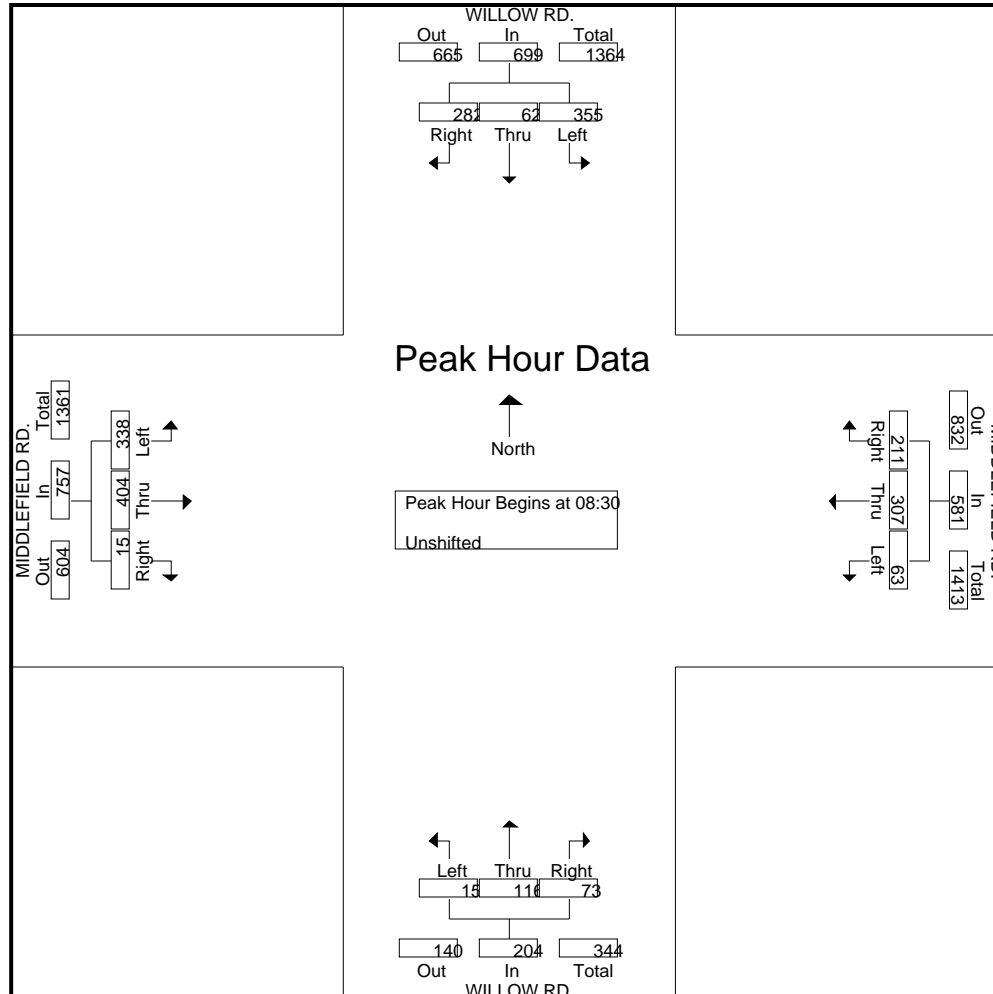

# Traffic Data Service

Campbell, CA  
(408) 377-2988  
tdsbay@cs.com

File Name : 10PM FINAL  
Site Code : 00000010  
Start Date : 11/10/2010  
Page No : 1

### Groups Printed- Vehicles

Start Time	MIDDLEFIELD RD Southbound					WILLOW RD Westbound					MIDDLEFIELD RD Northbound					WILLOW RD Eastbound					Int. Total
	Right	Thru	Left	Peds	App. Total	Right	Thru	Left	Peds	App. Total	Right	Thru	Left	Peds	App. Total	Right	Thru	Left	Peds	App. Total	
04:00 PM	5	75	133	0	213	93	21	60	0	174	91	94	12	0	197	31	46	3	0	80	664
04:15 PM	3	88	118	0	209	79	23	74	0	176	104	107	20	0	231	30	26	4	0	60	676
04:30 PM	4	79	106	0	189	103	18	58	0	179	118	89	31	0	238	37	56	11	0	104	710
04:45 PM	4	85	101	0	190	97	20	82	0	199	143	110	20	0	273	43	43	10	0	96	758
<b>Total</b>	<b>16</b>	<b>327</b>	<b>458</b>	<b>0</b>	<b>801</b>	<b>372</b>	<b>82</b>	<b>274</b>	<b>0</b>	<b>728</b>	<b>456</b>	<b>400</b>	<b>83</b>	<b>0</b>	<b>939</b>	<b>141</b>	<b>171</b>	<b>28</b>	<b>0</b>	<b>340</b>	<b>2808</b>
05:00 PM	5	107	129	0	241	98	28	84	0	210	97	115	21	0	233	31	38	3	0	72	756
05:15 PM	7	111	117	0	235	97	25	105	0	227	126	89	22	0	237	41	37	11	0	89	788
05:30 PM	3	110	130	0	243	118	22	111	0	251	125	124	34	0	283	43	52	12	0	107	884
05:45 PM	2	72	93	0	167	107	19	77	0	203	95	120	17	0	232	46	49	3	0	98	700
<b>Total</b>	<b>17</b>	<b>400</b>	<b>469</b>	<b>0</b>	<b>886</b>	<b>420</b>	<b>94</b>	<b>377</b>	<b>0</b>	<b>891</b>	<b>443</b>	<b>448</b>	<b>94</b>	<b>0</b>	<b>985</b>	<b>161</b>	<b>176</b>	<b>29</b>	<b>0</b>	<b>366</b>	<b>3128</b>
<b>Grand Total</b>	<b>33</b>	<b>727</b>	<b>927</b>	<b>0</b>	<b>1687</b>	<b>792</b>	<b>176</b>	<b>651</b>	<b>0</b>	<b>1619</b>	<b>899</b>	<b>848</b>	<b>177</b>	<b>0</b>	<b>1924</b>	<b>302</b>	<b>347</b>	<b>57</b>	<b>0</b>	<b>706</b>	<b>5936</b>
Apprch %	2	43.1	54.9	0		48.9	10.9	40.2	0		46.7	44.1	9.2	0		42.8	49.2	8.1	0		
Total %	0.6	12.2	15.6	0	28.4	13.3	3	11	0	27.3	15.1	14.3	3	0	32.4	5.1	5.8	1	0	11.9	

Start Time	MIDDLEFIELD RD Southbound					WILLOW RD Westbound					MIDDLEFIELD RD Northbound					WILLOW RD Eastbound					Int. Total
	Right	Thru	Left	Peds	App. Total	Right	Thru	Left	Peds	App. Total	Right	Thru	Left	Peds	App. Total	Right	Thru	Left	Peds	App. Total	
Peak Hour Analysis From 04:00 PM to 05:45 PM - Peak 1 of 1																					
Peak Hour for Entire Intersection Begins at 04:45 PM																					
04:45 PM	4	85	101	0	190	97	20	82	0	199	143	110	20	0	273	43	43	10	0	96	758
05:00 PM	5	107	129	0	241	98	28	84	0	210	97	115	21	0	233	31	38	3	0	72	756
05:15 PM	7	111	117	0	235	97	25	105	0	227	126	89	22	0	237	41	37	11	0	89	788
05:30 PM	3	110	130	0	243	118	22	111	0	251	125	124	34	0	283	43	52	12	0	107	884
Total Volume	19	413	477	0	909	410	95	382	0	887	491	438	97	0	1026	158	170	36	0	364	3186
% App. Total	2.1	45.4	52.5	0		46.2	10.7	43.1	0		47.9	42.7	9.5	0		43.4	46.7	9.9	0		
PHF	.679	.930	.917	.000	.935	.869	.848	.860	.000	.883	.858	.883	.713	.000	.906	.919	.817	.750	.000	.850	.901

# Traffic Data Service

Campbell, CA  
 (408) 377-2988  
 tdsbay@cs.com

File Name : 10PM FINAL  
 Site Code : 00000010  
 Start Date : 11/10/2010  
 Page No : 2

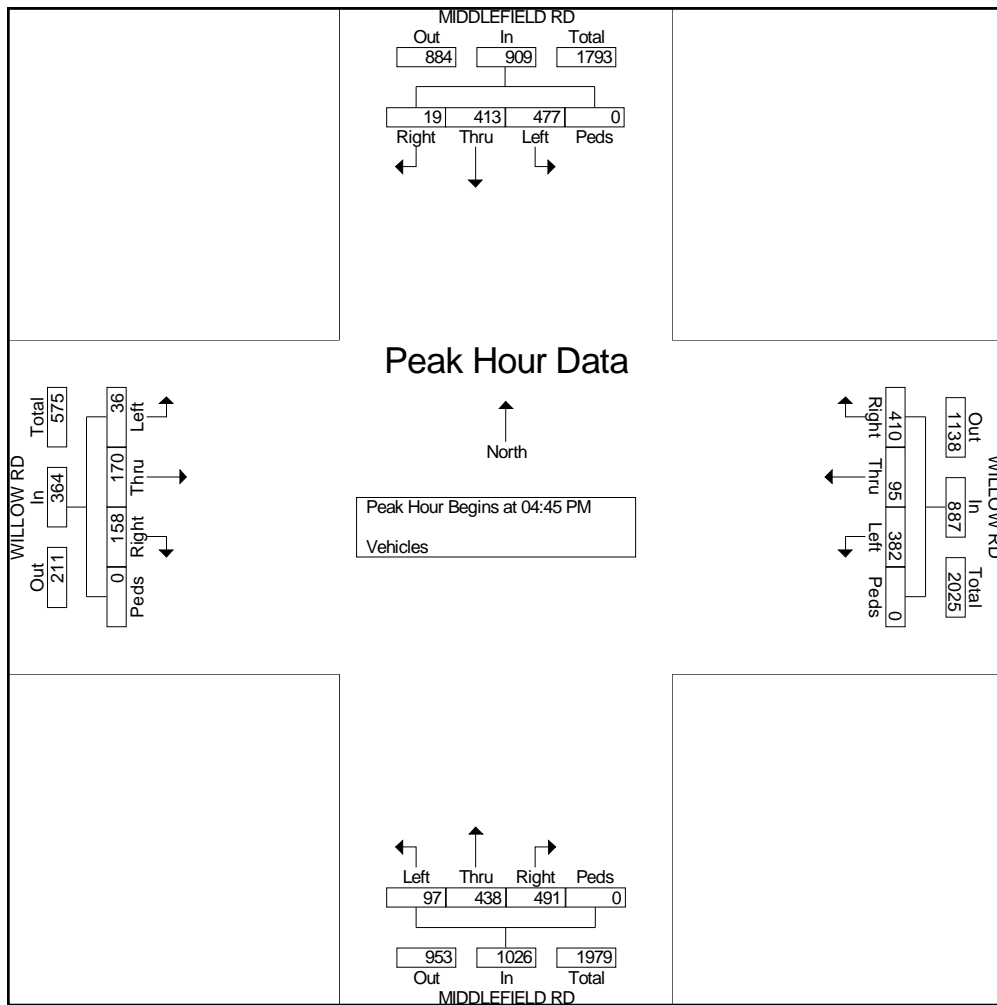

# Traffic Data Service

Campbell, CA  
 (408) 377-2988  
 tdsbay@cs.com

File Name : 1AM FINAL  
 Site Code : 00000001  
 Start Date : 11/9/2010  
 Page No : 1

### Groups Printed- Vehicles

Start Time	BAYFRONT EXPY Southbound					Westbound					BAYFRONT EXPY Northbound					UNIVERSITY AVE Eastbound					Int. Total
	Right	Thru	Left	Peds	App. Total	Right	Thru	Left	Peds	App. Total	Right	Thru	Left	Peds	App. Total	Right	Thru	Left	Peds	App. Total	
07:00 AM	11	195	0	0	206	0	0	0	0	0	0	661	293	0	954	78	0	29	0	107	1267
07:15 AM	14	248	0	0	262	0	0	0	0	0	0	770	403	0	1173	85	0	34	0	119	1554
07:30 AM	28	248	0	0	276	0	0	0	0	0	0	759	361	0	1120	101	0	42	0	143	1539
07:45 AM	49	196	0	0	245	0	0	0	0	0	0	705	378	0	1083	107	0	54	0	161	1489
<b>Total</b>	<b>102</b>	<b>887</b>	<b>0</b>	<b>0</b>	<b>989</b>	<b>0</b>	<b>0</b>	<b>0</b>	<b>0</b>	<b>0</b>	<b>0</b>	<b>2895</b>	<b>1435</b>	<b>0</b>	<b>4330</b>	<b>371</b>	<b>0</b>	<b>159</b>	<b>0</b>	<b>530</b>	<b>5849</b>
08:00 AM	50	220	0	0	270	0	0	0	0	0	0	718	362	0	1080	108	0	41	0	149	1499
08:15 AM	61	220	0	0	281	0	0	0	0	0	0	700	440	0	1140	113	0	42	0	155	1576
08:30 AM	52	247	0	0	299	0	0	0	0	0	0	650	380	0	1030	94	0	27	0	121	1450
08:45 AM	33	235	0	0	268	0	0	0	0	0	0	703	333	0	1036	85	0	21	0	106	1410
<b>Total</b>	<b>196</b>	<b>922</b>	<b>0</b>	<b>0</b>	<b>1118</b>	<b>0</b>	<b>0</b>	<b>0</b>	<b>0</b>	<b>0</b>	<b>0</b>	<b>2771</b>	<b>1515</b>	<b>0</b>	<b>4286</b>	<b>400</b>	<b>0</b>	<b>131</b>	<b>0</b>	<b>531</b>	<b>5935</b>
Grand Total	298	1809	0	0	2107	0	0	0	0	0	0	5666	2950	0	8616	771	0	290	0	1061	11784
Apprch %	14.1	85.9	0	0		0	0	0	0	0	0	65.8	34.2	0		72.7	0	27.3	0		
Total %	2.5	15.4	0	0	17.9	0	0	0	0	0	0	48.1	25	0	73.1	6.5	0	2.5	0	9	

Start Time	BAYFRONT EXPY Southbound					Westbound					BAYFRONT EXPY Northbound					UNIVERSITY AVE Eastbound					Int. Total	
	Right	Thru	Left	Peds	App. Total	Right	Thru	Left	Peds	App. Total	Right	Thru	Left	Peds	App. Total	Right	Thru	Left	Peds	App. Total		
Peak Hour Analysis From 07:00 AM to 08:45 AM - Peak 1 of 1																						
Peak Hour for Entire Intersection Begins at 07:30 AM																						
07:30 AM	28	248	0	0	276	0	0	0	0	0	0	759	361	0	1120	101	0	42	0	143	1539	
07:45 AM	49	196	0	0	245	0	0	0	0	0	0	705	378	0	1083	107	0	54	0	161	1489	
08:00 AM	50	220	0	0	270	0	0	0	0	0	0	718	362	0	1080	108	0	41	0	149	1499	
08:15 AM	61	220	0	0	281	0	0	0	0	0	0	700	440	0	1140	113	0	42	0	155	1576	
Total Volume	188	884	0	0	1072	0	0	0	0	0	0	2882	1541	0	4423	429	0	179	0	608	6103	
% App. Total																						
PHF	.770	.891	.000	.000	.954	.000	.000	.000	.000	.000	.000	.000	.949	.876	.000	.970	.949	.000	.829	.000	.944	.968

# Traffic Data Service

Campbell, CA  
 (408) 377-2988  
 tdsbay@cs.com

File Name : 1AM FINAL  
 Site Code : 00000001  
 Start Date : 11/9/2010  
 Page No : 2

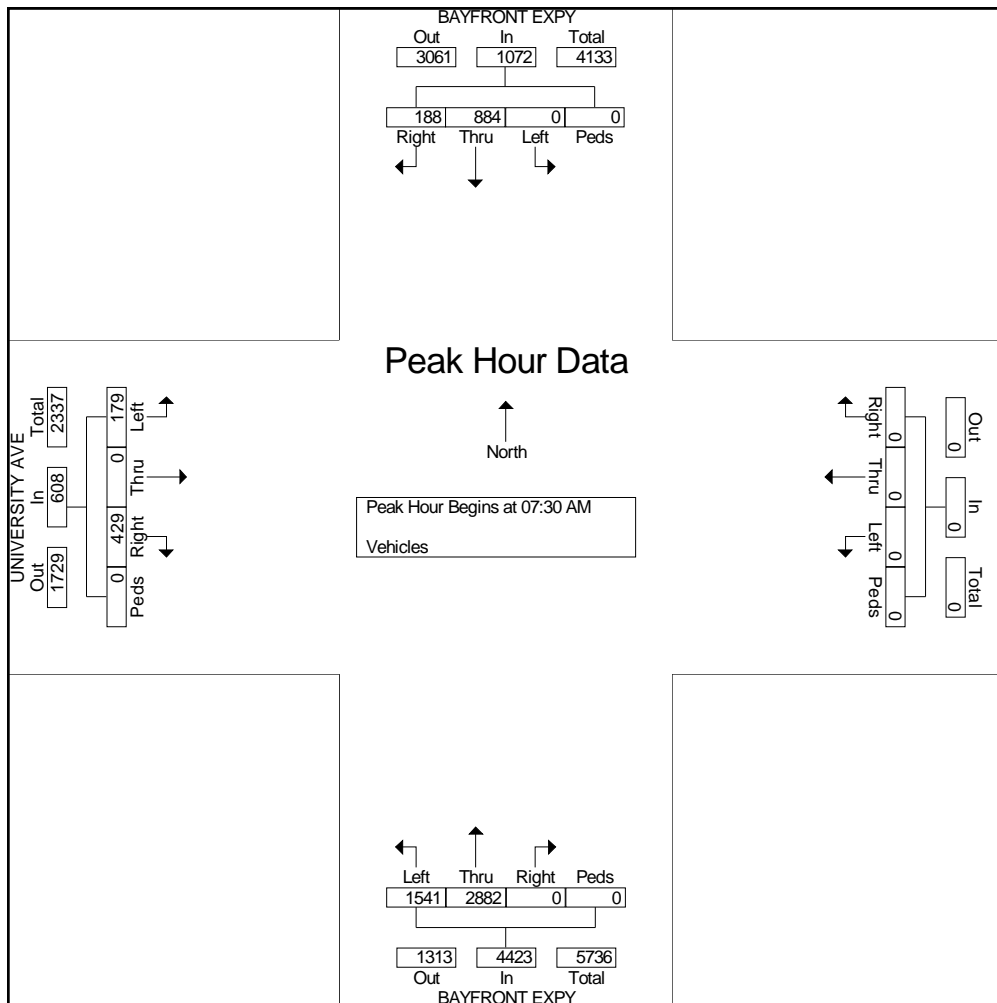

# Traffic Data Service

Campbell, CA  
(408) 377-2988  
tdsbay@cs.com

File Name : 1PM FINAL  
Site Code : 00000001  
Start Date : 11/9/2010  
Page No : 1

### Groups Printed- Vehicles

Start Time	BAYFRONT EXPY Southbound					Westbound					BAYFRONT EXPY Northbound					UNIVERSITY AVE Eastbound					Int. Total
	Right	Thru	Left	Peds	App. Total	Right	Thru	Left	Peds	App. Total	Right	Thru	Left	Peds	App. Total	Right	Thru	Left	Peds	App. Total	
04:00 PM	28	734	0	0	762	0	0	0	0	0	0	185	99	0	284	306	0	12	0	318	1364
04:15 PM	24	822	0	0	846	0	0	0	0	0	0	206	86	0	292	359	0	15	0	374	1512
04:30 PM	22	792	0	0	814	0	0	0	0	0	0	231	98	0	329	399	0	19	0	418	1561
04:45 PM	28	775	0	0	803	0	0	0	0	0	0	211	76	0	287	361	0	17	0	378	1468
<b>Total</b>	<b>102</b>	<b>3123</b>	<b>0</b>	<b>0</b>	<b>3225</b>	<b>0</b>	<b>0</b>	<b>0</b>	<b>0</b>	<b>0</b>	<b>0</b>	<b>833</b>	<b>359</b>	<b>0</b>	<b>1192</b>	<b>1425</b>	<b>0</b>	<b>63</b>	<b>0</b>	<b>1488</b>	<b>5905</b>
05:00 PM	32	824	0	0	856	0	0	0	0	0	0	233	81	0	314	415	0	20	0	435	1605
05:15 PM	24	920	0	0	944	0	0	0	0	0	0	249	95	0	344	425	0	15	0	440	1728
05:30 PM	40	887	0	0	927	0	0	0	0	0	0	258	101	0	359	412	0	13	0	425	1711
05:45 PM	31	857	0	0	888	0	0	0	0	0	0	228	100	0	328	415	0	12	0	427	1643
<b>Total</b>	<b>127</b>	<b>3488</b>	<b>0</b>	<b>0</b>	<b>3615</b>	<b>0</b>	<b>0</b>	<b>0</b>	<b>0</b>	<b>0</b>	<b>0</b>	<b>968</b>	<b>377</b>	<b>0</b>	<b>1345</b>	<b>1667</b>	<b>0</b>	<b>60</b>	<b>0</b>	<b>1727</b>	<b>6687</b>
Grand Total	229	6611	0	0	6840	0	0	0	0	0	0	1801	736	0	2537	3092	0	123	0	3215	12592
Apprch %	3.3	96.7	0	0		0	0	0	0	0	0	71	29	0		96.2	0	3.8	0		
Total %	1.8	52.5	0	0	54.3	0	0	0	0	0	0	14.3	5.8	0	20.1	24.6	0	1	0	25.5	

Start Time	BAYFRONT EXPY Southbound					Westbound					BAYFRONT EXPY Northbound					UNIVERSITY AVE Eastbound					Int. Total
	Right	Thru	Left	Peds	App. Total	Right	Thru	Left	Peds	App. Total	Right	Thru	Left	Peds	App. Total	Right	Thru	Left	Peds	App. Total	
Peak Hour Analysis From 04:00 PM to 05:45 PM - Peak 1 of 1																					
Peak Hour for Entire Intersection Begins at 05:00 PM																					
05:00 PM	32	824	0	0	856	0	0	0	0	0	0	233	81	0	314	415	0	20	0	435	1605
05:15 PM	24	920	0	0	944	0	0	0	0	0	0	249	95	0	344	425	0	15	0	440	1728
05:30 PM	40	887	0	0	927	0	0	0	0	0	0	258	101	0	359	412	0	13	0	425	1711
05:45 PM	31	857	0	0	888	0	0	0	0	0	0	228	100	0	328	415	0	12	0	427	1643
Total Volume	127	3488	0	0	3615	0	0	0	0	0	0	968	377	0	1345	1667	0	60	0	1727	6687
% App. Total																					
PHF	.794	.948	.000	.000	.957	.000	.000	.000	.000	.000	.000	.938	.933	.000	.937	.981	.000	.750	.000	.981	.967

# Traffic Data Service

Campbell, CA  
 (408) 377-2988  
 tdsbay@cs.com

File Name : 1PM FINAL  
 Site Code : 00000001  
 Start Date : 11/9/2010  
 Page No : 2

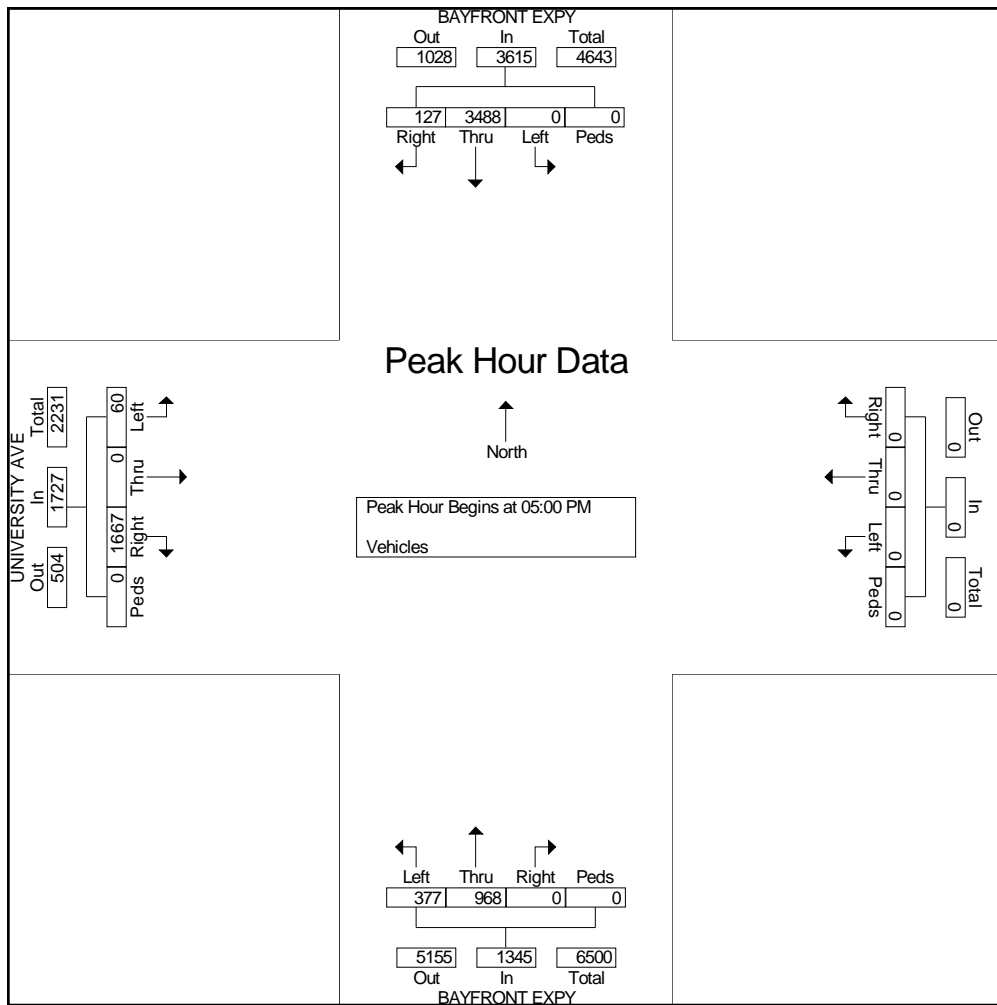

# Traffic Data Service

Campbell, CA  
(408) 377-2988  
tdsbay@cs.com

File Name : 2AM FINAL  
Site Code : 00000002  
Start Date : 11/9/2010  
Page No : 1

### Groups Printed- Vehicles

Start Time	O'BRIEN DR Southbound					UNIVERSITY AVE Westbound					Northbound					UNIVERSITY AVE Eastbound					Int. Total
	Right	Thru	Left	Peds	App. Total	Right	Thru	Left	Peds	App. Total	Right	Thru	Left	Peds	App. Total	Right	Thru	Left	Peds	App. Total	
07:00 AM	0	0	3	0	3	12	253	0	0	265	0	0	0	0	0	0	92	9	0	101	369
07:15 AM	3	0	1	0	4	7	322	0	0	329	0	0	0	0	0	0	125	8	0	133	466
07:30 AM	9	0	4	0	13	12	345	0	0	357	0	0	0	0	0	0	123	12	0	135	505
07:45 AM	5	0	4	0	9	13	348	0	0	361	0	0	0	0	0	0	142	18	0	160	530
<b>Total</b>	<b>17</b>	<b>0</b>	<b>12</b>	<b>0</b>	<b>29</b>	<b>44</b>	<b>1268</b>	<b>0</b>	<b>0</b>	<b>1312</b>	<b>0</b>	<b>0</b>	<b>0</b>	<b>0</b>	<b>0</b>	<b>0</b>	<b>482</b>	<b>47</b>	<b>0</b>	<b>529</b>	<b>1870</b>
08:00 AM	2	0	5	0	7	16	321	0	0	337	0	0	0	0	0	0	119	20	0	139	483
08:15 AM	6	0	9	0	15	5	327	0	0	332	0	0	0	0	0	0	142	18	0	160	507
08:30 AM	12	0	5	0	17	6	315	0	0	321	0	0	0	0	0	0	104	22	0	126	464
08:45 AM	6	0	8	0	14	12	319	0	0	331	0	0	0	0	0	0	124	16	0	140	485
<b>Total</b>	<b>26</b>	<b>0</b>	<b>27</b>	<b>0</b>	<b>53</b>	<b>39</b>	<b>1282</b>	<b>0</b>	<b>0</b>	<b>1321</b>	<b>0</b>	<b>0</b>	<b>0</b>	<b>0</b>	<b>0</b>	<b>0</b>	<b>489</b>	<b>76</b>	<b>0</b>	<b>565</b>	<b>1939</b>
Grand Total	43	0	39	0	82	83	2550	0	0	2633	0	0	0	0	0	0	971	123	0	1094	3809
Apprch %	52.4	0	47.6	0		3.2	96.8	0	0		0	0	0	0		0	88.8	11.2	0		
Total %	1.1	0	1	0	2.2	2.2	66.9	0	0	69.1	0	0	0	0	0	0	25.5	3.2	0	28.7	

Start Time	O'BRIEN DR Southbound					UNIVERSITY AVE Westbound					Northbound					UNIVERSITY AVE Eastbound					Int. Total
	Right	Thru	Left	Peds	App. Total	Right	Thru	Left	Peds	App. Total	Right	Thru	Left	Peds	App. Total	Right	Thru	Left	Peds	App. Total	
Peak Hour Analysis From 07:00 AM to 08:45 AM - Peak 1 of 1																					
Peak Hour for Entire Intersection Begins at 07:30 AM																					
07:30 AM	9	0	4	0	13	12	345	0	0	357	0	0	0	0	0	0	123	12	0	135	505
07:45 AM	5	0	4	0	9	13	348	0	0	361	0	0	0	0	0	0	142	18	0	160	530
08:00 AM	2	0	5	0	7	16	321	0	0	337	0	0	0	0	0	0	119	20	0	139	483
08:15 AM	6	0	9	0	15	5	327	0	0	332	0	0	0	0	0	0	142	18	0	160	507
Total Volume	22	0	22	0	44	46	1341	0	0	1387	0	0	0	0	0	0	526	68	0	594	2025
% App. Total																					
PHF	.611	.000	.611	.000	.733	.719	.963	.000	.000	.961	.000	.000	.000	.000	.000	.000	.926	.850	.000	.928	.955



# Traffic Data Service

Campbell, CA  
 (408) 377-2988  
 tdsbay@cs.com

File Name : 2AM FINAL  
 Site Code : 00000002  
 Start Date : 11/9/2010  
 Page No : 2

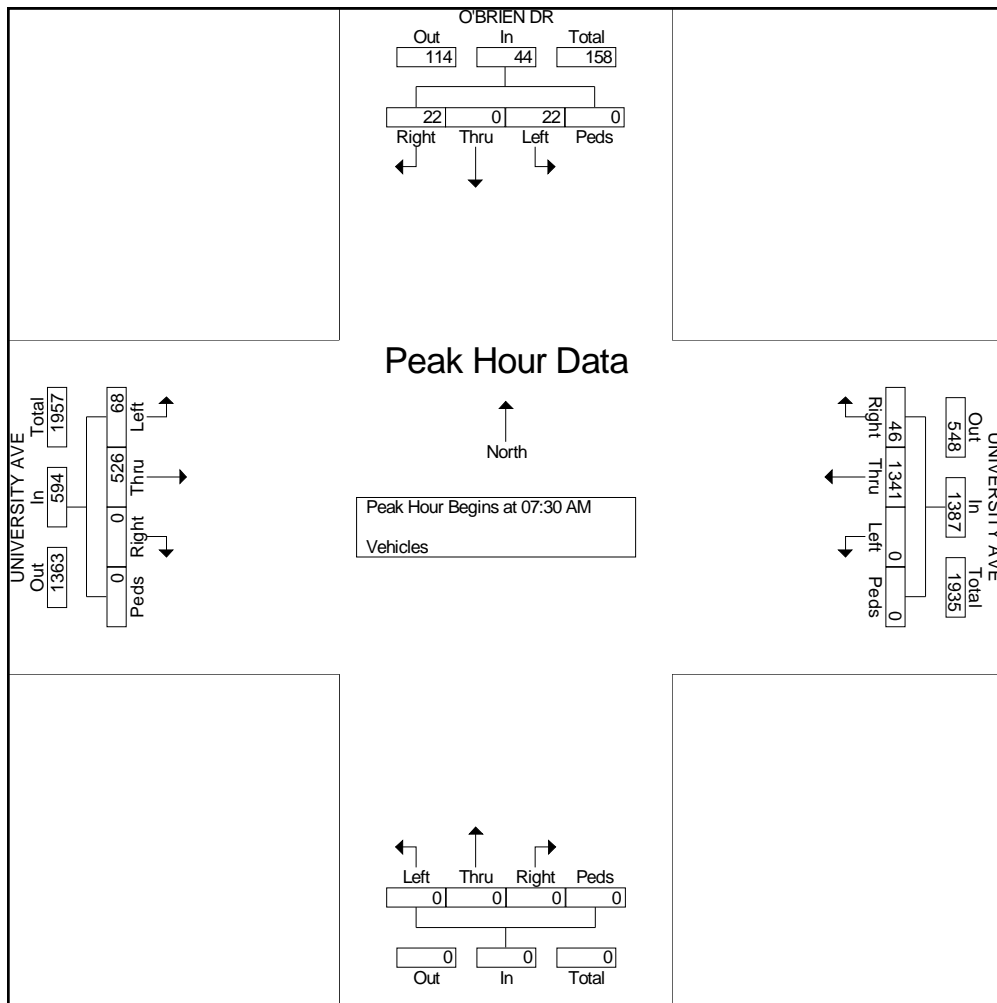

# Traffic Data Service

Campbell, CA  
(408) 377-2988  
tdsbay@cs.com

File Name : 2PM FINAL  
Site Code : 00000002  
Start Date : 11/9/2010  
Page No : 1

### Groups Printed- Vehicles

Start Time	O-BRIEN DR Southbound					UNIVERSITY AVE Westbound					Northbound					UNIVERSITY AVE Eastbound					Int. Total
	Right	Thru	Left	Peds	App. Total	Right	Thru	Left	Peds	App. Total	Right	Thru	Left	Peds	App. Total	Right	Thru	Left	Peds	App. Total	
04:00 PM	17	0	17	0	34	3	107	0	0	110	0	0	0	0	0	0	339	3	0	342	486
04:15 PM	7	0	16	0	23	5	110	0	0	115	0	0	0	0	0	0	381	5	0	386	524
04:30 PM	16	0	28	0	44	3	110	0	0	113	0	0	0	0	0	0	425	3	0	428	585
04:45 PM	22	0	18	0	40	2	99	0	0	101	0	0	0	0	0	0	414	4	0	418	559
<b>Total</b>	<b>62</b>	<b>0</b>	<b>79</b>	<b>0</b>	<b>141</b>	<b>13</b>	<b>426</b>	<b>0</b>	<b>0</b>	<b>439</b>	<b>0</b>	<b>0</b>	<b>0</b>	<b>0</b>	<b>0</b>	<b>0</b>	<b>1559</b>	<b>15</b>	<b>0</b>	<b>1574</b>	<b>2154</b>
05:00 PM	32	0	35	0	67	5	120	0	0	125	0	0	0	0	0	0	364	8	0	372	564
05:15 PM	29	0	39	0	68	6	125	0	0	131	0	0	0	0	0	0	396	5	0	401	600
05:30 PM	20	0	33	0	53	6	117	0	0	123	0	0	0	0	0	0	341	4	0	345	521
05:45 PM	20	0	20	0	40	5	121	0	0	126	0	0	0	0	0	0	411	5	0	416	582
<b>Total</b>	<b>101</b>	<b>0</b>	<b>127</b>	<b>0</b>	<b>228</b>	<b>22</b>	<b>483</b>	<b>0</b>	<b>0</b>	<b>505</b>	<b>0</b>	<b>0</b>	<b>0</b>	<b>0</b>	<b>0</b>	<b>0</b>	<b>1512</b>	<b>22</b>	<b>0</b>	<b>1534</b>	<b>2267</b>
Grand Total	163	0	206	0	369	35	909	0	0	944	0	0	0	0	0	0	3071	37	0	3108	4421
Apprch %	44.2	0	55.8	0		3.7	96.3	0	0		0	0	0	0		0	98.8	1.2	0		
Total %	3.7	0	4.7	0	8.3	0.8	20.6	0	0	21.4	0	0	0	0		0	69.5	0.8	0	70.3	

Start Time	O-BRIEN DR Southbound					UNIVERSITY AVE Westbound					Northbound					UNIVERSITY AVE Eastbound					Int. Total
	Right	Thru	Left	Peds	App. Total	Right	Thru	Left	Peds	App. Total	Right	Thru	Left	Peds	App. Total	Right	Thru	Left	Peds	App. Total	
Peak Hour Analysis From 04:00 PM to 05:45 PM - Peak 1 of 1																					
Peak Hour for Entire Intersection Begins at 04:30 PM																					
04:30 PM	16	0	28	0	44	3	110	0	0	113	0	0	0	0	0	0	425	3	0	428	585
04:45 PM	22	0	18	0	40	2	99	0	0	101	0	0	0	0	0	0	414	4	0	418	559
05:00 PM	32	0	35	0	67	5	120	0	0	125	0	0	0	0	0	0	364	8	0	372	564
05:15 PM	29	0	39	0	68	6	125	0	0	131	0	0	0	0	0	0	396	5	0	401	600
Total Volume	99	0	120	0	219	16	454	0	0	470	0	0	0	0	0	0	1599	20	0	1619	2308
% App. Total																					
PHF	.773	.000	.769	.000	.805	.667	.908	.000	.000	.897	.000	.000	.000	.000	.000	.000	.941	.625	.000	.946	.962

# Traffic Data Service

Campbell, CA  
 (408) 377-2988  
 tdsbay@cs.com

File Name : 2PM FINAL  
 Site Code : 00000002  
 Start Date : 11/9/2010  
 Page No : 2

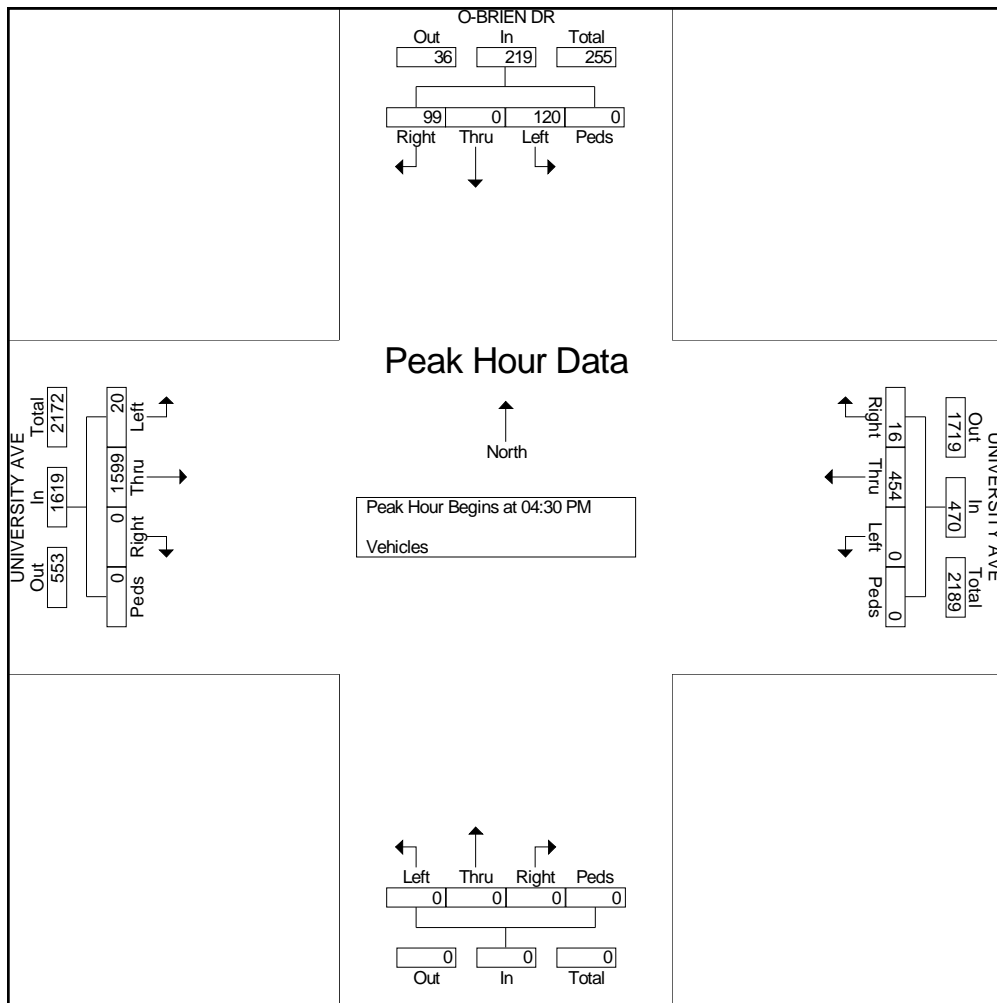

# Traffic Data Service

Campbell, CA  
(408) 377-2988  
tdsbay@cs.com

File Name : 3AM FINAL  
Site Code : 00000003  
Start Date : 11/9/2010  
Page No : 1

### Groups Printed- Vehicles

Start Time	KAVANAUGH DR Southbound					UNIVERSITY AVE Westbound					NOTRE DAME AVE Northbound					UNIVERSITY AVE Eastbound					Int. Total
	Right	Thru	Left	Peds	App. Total	Right	Thru	Left	Peds	App. Total	Right	Thru	Left	Peds	App. Total	Right	Thru	Left	Peds	App. Total	
07:00 AM	7	4	1	0	12	2	263	1	0	266	6	2	16	0	24	4	98	3	0	105	407
07:15 AM	11	6	1	0	18	3	307	0	0	310	3	1	5	0	9	7	124	2	0	133	470
07:30 AM	9	3	1	0	13	3	347	1	0	351	4	4	12	0	20	10	135	4	0	149	533
07:45 AM	14	3	0	0	17	13	328	3	0	344	4	13	7	0	24	10	151	8	0	169	554
<b>Total</b>	<b>41</b>	<b>16</b>	<b>3</b>	<b>0</b>	<b>60</b>	<b>21</b>	<b>1245</b>	<b>5</b>	<b>0</b>	<b>1271</b>	<b>17</b>	<b>20</b>	<b>40</b>	<b>0</b>	<b>77</b>	<b>31</b>	<b>508</b>	<b>17</b>	<b>0</b>	<b>556</b>	<b>1964</b>
08:00 AM	12	7	3	0	22	5	310	4	0	319	6	10	7	0	23	8	154	16	0	178	542
08:15 AM	9	8	4	0	21	4	317	17	0	338	6	10	6	0	22	15	142	12	0	169	550
08:30 AM	8	4	2	0	14	2	324	1	0	327	3	8	7	0	18	5	133	7	0	145	504
08:45 AM	8	3	1	0	12	7	335	2	0	344	0	6	6	0	12	3	125	4	0	132	500
<b>Total</b>	<b>37</b>	<b>22</b>	<b>10</b>	<b>0</b>	<b>69</b>	<b>18</b>	<b>1286</b>	<b>24</b>	<b>0</b>	<b>1328</b>	<b>15</b>	<b>34</b>	<b>26</b>	<b>0</b>	<b>75</b>	<b>31</b>	<b>554</b>	<b>39</b>	<b>0</b>	<b>624</b>	<b>2096</b>
Grand Total	78	38	13	0	129	39	2531	29	0	2599	32	54	66	0	152	62	1062	56	0	1180	4060
Apprch %	60.5	29.5	10.1	0		1.5	97.4	1.1	0		21.1	35.5	43.4	0		5.3	90	4.7	0		
Total %	1.9	0.9	0.3	0	3.2	1	62.3	0.7	0	64	0.8	1.3	1.6	0	3.7	1.5	26.2	1.4	0	29.1	

Start Time	KAVANAUGH DR Southbound					UNIVERSITY AVE Westbound					NOTRE DAME AVE Northbound					UNIVERSITY AVE Eastbound					Int. Total
	Right	Thru	Left	Peds	App. Total	Right	Thru	Left	Peds	App. Total	Right	Thru	Left	Peds	App. Total	Right	Thru	Left	Peds	App. Total	
Peak Hour Analysis From 07:00 AM to 08:45 AM - Peak 1 of 1																					
Peak Hour for Entire Intersection Begins at 07:30 AM																					
07:30 AM	9	3	1	0	13	3	347	1	0	351	4	4	12	0	20	10	135	4	0	149	533
07:45 AM	14	3	0	0	17	13	328	3	0	344	4	13	7	0	24	10	151	8	0	169	554
08:00 AM	12	7	3	0	22	5	310	4	0	319	6	10	7	0	23	8	154	16	0	178	542
08:15 AM	9	8	4	0	21	4	317	17	0	338	6	10	6	0	22	15	142	12	0	169	550
Total Volume	44	21	8	0	73	25	1302	25	0	1352	20	37	32	0	89	43	582	40	0	665	2179
% App. Total																					
PHF	.786	.656	.500	.000	.830	.481	.938	.368	.000	.963	.833	.712	.667	.000	.927	.717	.945	.625	.000	.934	.983

# Traffic Data Service

Campbell, CA  
 (408) 377-2988  
 tdsbay@cs.com

File Name : 3AM FINAL  
 Site Code : 00000003  
 Start Date : 11/9/2010  
 Page No : 2

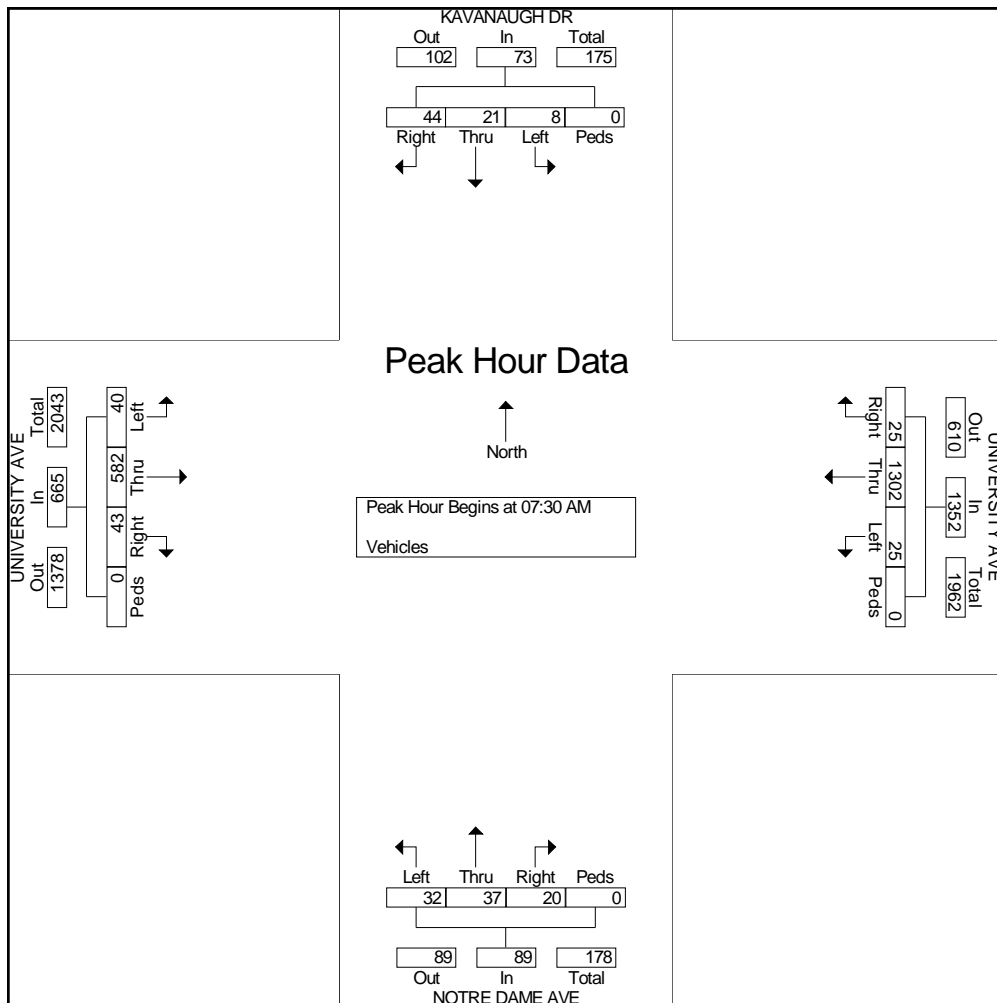

# Traffic Data Service

Campbell, CA  
(408) 377-2988  
tdsbay@cs.com

File Name : 3PM FINAL  
Site Code : 00000003  
Start Date : 11/9/2010  
Page No : 1

### Groups Printed- Vehicles

Start Time	KAVANAUGH DR Southbound					UNIVERSITY AVE Westbound					NOTRE DAME AVE Northbound					UNIVERSITY AVE Eastbound					Int. Total
	Right	Thru	Left	Peds	App. Total	Right	Thru	Left	Peds	App. Total	Right	Thru	Left	Peds	App. Total	Right	Thru	Left	Peds	App. Total	
04:00 PM	18	3	4	0	25	5	118	6	0	129	6	9	12	0	27	6	338	13	0	357	538
04:15 PM	8	5	2	0	15	4	103	3	0	110	3	8	12	0	23	3	390	9	0	402	550
04:30 PM	18	8	6	0	32	2	124	2	0	128	2	9	6	0	17	3	410	9	0	422	599
04:45 PM	18	5	4	0	27	4	107	1	0	112	3	6	9	0	18	5	416	5	0	426	583
<b>Total</b>	<b>62</b>	<b>21</b>	<b>16</b>	<b>0</b>	<b>99</b>	<b>15</b>	<b>452</b>	<b>12</b>	<b>0</b>	<b>479</b>	<b>14</b>	<b>32</b>	<b>39</b>	<b>0</b>	<b>85</b>	<b>17</b>	<b>1554</b>	<b>36</b>	<b>0</b>	<b>1607</b>	<b>2270</b>
05:00 PM	28	10	2	0	40	3	141	10	0	154	5	3	16	0	24	5	362	7	0	374	592
05:15 PM	18	6	7	0	31	4	155	5	0	164	2	13	4	0	19	6	391	5	0	402	616
05:30 PM	17	8	2	0	27	7	132	8	0	147	3	8	5	0	16	4	341	8	0	353	543
05:45 PM	18	5	5	0	28	4	130	0	0	134	4	5	12	0	21	3	400	4	0	407	590
<b>Total</b>	<b>81</b>	<b>29</b>	<b>16</b>	<b>0</b>	<b>126</b>	<b>18</b>	<b>558</b>	<b>23</b>	<b>0</b>	<b>599</b>	<b>14</b>	<b>29</b>	<b>37</b>	<b>0</b>	<b>80</b>	<b>18</b>	<b>1494</b>	<b>24</b>	<b>0</b>	<b>1536</b>	<b>2341</b>
Grand Total	143	50	32	0	225	33	1010	35	0	1078	28	61	76	0	165	35	3048	60	0	3143	4611
Apprch %	63.6	22.2	14.2	0		3.1	93.7	3.2	0		1.7	37	46.1	0		1.1	97	1.9	0		
Total %	3.1	1.1	0.7	0	4.9	0.7	21.9	0.8	0	23.4	0.6	1.3	1.6	0	3.6	0.8	66.1	1.3	0	68.2	

Start Time	KAVANAUGH DR Southbound					UNIVERSITY AVE Westbound					NOTRE DAME AVE Northbound					UNIVERSITY AVE Eastbound					Int. Total
	Right	Thru	Left	Peds	App. Total	Right	Thru	Left	Peds	App. Total	Right	Thru	Left	Peds	App. Total	Right	Thru	Left	Peds	App. Total	
Peak Hour Analysis From 04:00 PM to 05:45 PM - Peak 1 of 1																					
Peak Hour for Entire Intersection Begins at 04:30 PM																					
04:30 PM	18	8	6	0	32	2	124	2	0	128	2	9	6	0	17	3	410	9	0	422	599
04:45 PM	18	5	4	0	27	4	107	1	0	112	3	6	9	0	18	5	416	5	0	426	583
05:00 PM	28	10	2	0	40	3	141	10	0	154	5	3	16	0	24	5	362	7	0	374	592
05:15 PM	18	6	7	0	31	4	155	5	0	164	2	13	4	0	19	6	391	5	0	402	616
Total Volume	82	29	19	0	130	13	527	18	0	558	12	31	35	0	78	19	1579	26	0	1624	2390
% App. Total																					
PHF	.732	.725	.679	.000	.813	.813	.850	.450	.000	.851	.600	.596	.547	.000	.813	.792	.949	.722	.000	.953	.970

# Traffic Data Service

Campbell, CA  
 (408) 377-2988  
 tdsbay@cs.com

File Name : 3PM FINAL  
 Site Code : 00000003  
 Start Date : 11/9/2010  
 Page No : 2

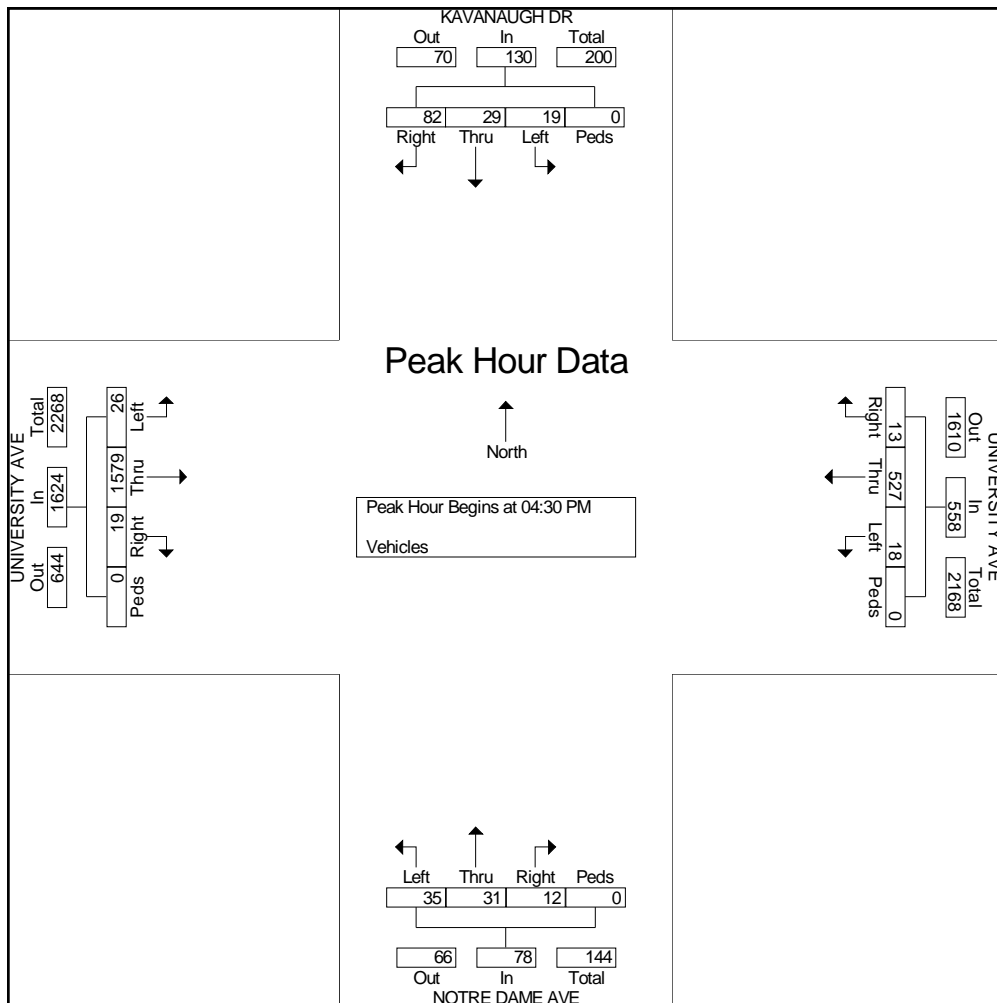

# Traffic Data Service

Campbell, CA  
(408) 377-2988  
tdsbay@cs.com

File Name : 4AM FINAL  
Site Code : 00000004  
Start Date : 11/9/2010  
Page No : 1

### Groups Printed- Vehicles

Start Time	BAY RD Southbound					UNIVERSITY AVE Westbound					BAY RD Northbound					UNIVERSITY AVE Eastbound					Int. Total
	Right	Thru	Left	Peds	App. Total	Right	Thru	Left	Peds	App. Total	Right	Thru	Left	Peds	App. Total	Right	Thru	Left	Peds	App. Total	
07:00 AM	20	42	17	0	79	10	236	13	0	259	11	27	42	0	80	11	81	11	0	103	521
07:15 AM	18	30	10	0	58	18	293	15	0	326	30	33	38	0	101	21	101	25	0	147	632
07:30 AM	19	59	12	0	90	13	287	22	0	322	25	56	29	0	110	25	99	24	0	148	670
07:45 AM	11	56	14	0	81	6	283	21	0	310	37	65	18	0	120	12	134	39	0	185	696
<b>Total</b>	<b>68</b>	<b>187</b>	<b>53</b>	<b>0</b>	<b>308</b>	<b>47</b>	<b>1099</b>	<b>71</b>	<b>0</b>	<b>1217</b>	<b>103</b>	<b>181</b>	<b>127</b>	<b>0</b>	<b>411</b>	<b>69</b>	<b>415</b>	<b>99</b>	<b>0</b>	<b>583</b>	<b>2519</b>
08:00 AM	29	41	8	0	78	21	248	23	0	292	23	63	29	0	115	20	118	39	0	177	662
08:15 AM	27	40	16	0	83	9	297	31	0	337	28	41	32	0	101	21	146	39	0	206	727
08:30 AM	33	47	21	0	101	15	281	20	0	316	9	38	39	0	86	15	116	25	0	156	659
08:45 AM	14	42	7	0	63	4	311	29	0	344	19	19	13	0	51	12	108	16	0	136	594
<b>Total</b>	<b>103</b>	<b>170</b>	<b>52</b>	<b>0</b>	<b>325</b>	<b>49</b>	<b>1137</b>	<b>103</b>	<b>0</b>	<b>1289</b>	<b>79</b>	<b>161</b>	<b>113</b>	<b>0</b>	<b>353</b>	<b>68</b>	<b>488</b>	<b>119</b>	<b>0</b>	<b>675</b>	<b>2642</b>
<b>Grand Total</b>	<b>171</b>	<b>357</b>	<b>105</b>	<b>0</b>	<b>633</b>	<b>96</b>	<b>2236</b>	<b>174</b>	<b>0</b>	<b>2506</b>	<b>182</b>	<b>342</b>	<b>240</b>	<b>0</b>	<b>764</b>	<b>137</b>	<b>903</b>	<b>218</b>	<b>0</b>	<b>1258</b>	<b>5161</b>
Apprch %	27	56.4	16.6	0		3.8	89.2	6.9	0		23.8	44.8	31.4	0		10.9	71.8	17.3	0		
Total %	3.3	6.9	2	0	12.3	1.9	43.3	3.4	0	48.6	3.5	6.6	4.7	0	14.8	2.7	17.5	4.2	0	24.4	

Start Time	BAY RD Southbound					UNIVERSITY AVE Westbound					BAY RD Northbound					UNIVERSITY AVE Eastbound					Int. Total
	Right	Thru	Left	Peds	App. Total	Right	Thru	Left	Peds	App. Total	Right	Thru	Left	Peds	App. Total	Right	Thru	Left	Peds	App. Total	
Peak Hour Analysis From 07:00 AM to 08:45 AM - Peak 1 of 1																					
Peak Hour for Entire Intersection Begins at 07:30 AM																					
07:30 AM	19	59	12	0	90	13	287	22	0	322	25	56	29	0	110	25	99	24	0	148	670
07:45 AM	11	56	14	0	81	6	283	21	0	310	37	65	18	0	120	12	134	39	0	185	696
08:00 AM	29	41	8	0	78	21	248	23	0	292	23	63	29	0	115	20	118	39	0	177	662
08:15 AM	27	40	16	0	83	9	297	31	0	337	28	41	32	0	101	21	146	39	0	206	727
<b>Total Volume</b>	<b>86</b>	<b>196</b>	<b>50</b>	<b>0</b>	<b>332</b>	<b>49</b>	<b>1115</b>	<b>97</b>	<b>0</b>	<b>1261</b>	<b>113</b>	<b>225</b>	<b>108</b>	<b>0</b>	<b>446</b>	<b>78</b>	<b>497</b>	<b>141</b>	<b>0</b>	<b>716</b>	<b>2755</b>
% App. Total																					
PHF	.741	.831	.781	.000	.922	.583	.939	.782	.000	.935	.764	.865	.844	.000	.929	.780	.851	.904	.000	.869	.947



# Traffic Data Service

Campbell, CA  
 (408) 377-2988  
 tdsbay@cs.com

File Name : 4AM FINAL  
 Site Code : 00000004  
 Start Date : 11/9/2010  
 Page No : 2

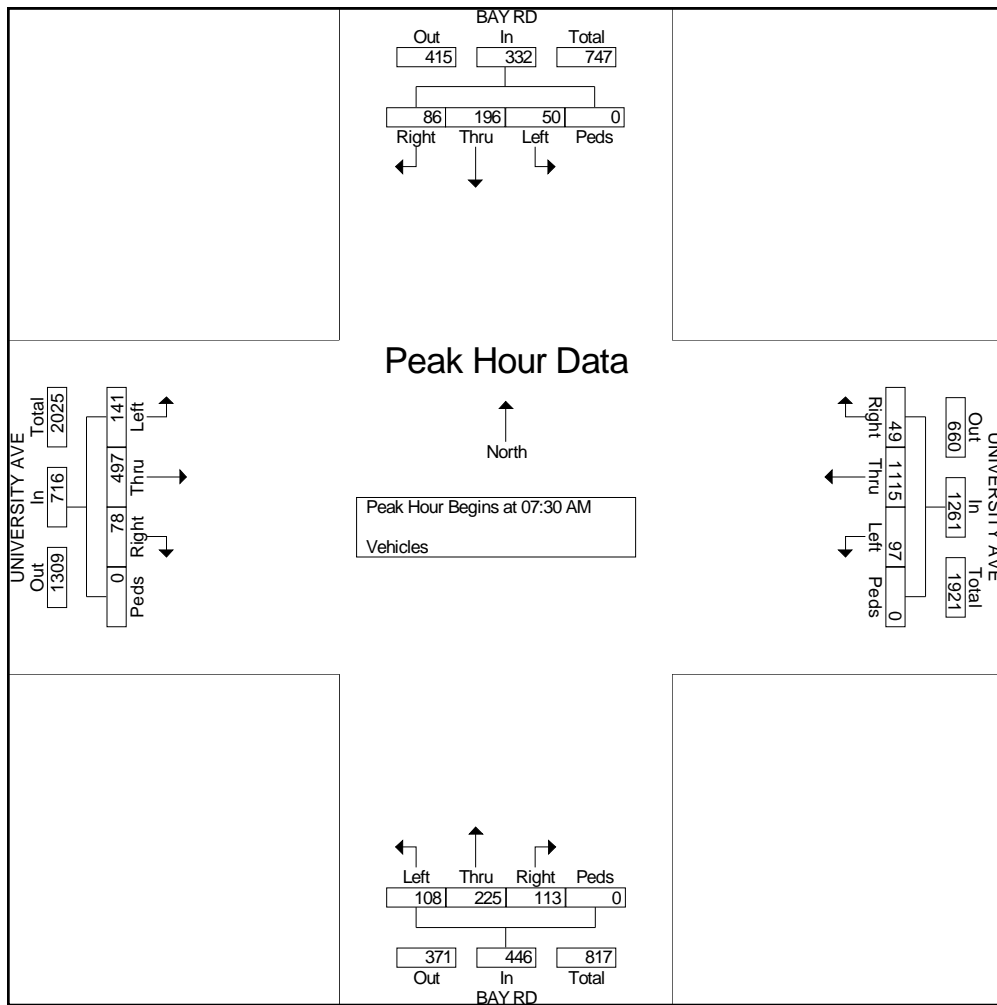

# Traffic Data Service

Campbell, CA  
(408) 377-2988  
tdsbay@cs.com

File Name : 4PM FINAL  
Site Code : 00000004  
Start Date : 11/9/2010  
Page No : 1

### Groups Printed- Vehicles

Start Time	BAY RD Southbound					UNIVERSITY AVE Westbound					BAY RD Northbound					UNIVERSITY AVE Eastbound					Int. Total
	Right	Thru	Left	Peds	App. Total	Right	Thru	Left	Peds	App. Total	Right	Thru	Left	Peds	App. Total	Right	Thru	Left	Peds	App. Total	
04:00 PM	35	54	19	0	108	1	106	31	0	138	55	62	46	0	163	33	287	14	0	334	743
04:15 PM	26	46	23	0	95	7	131	36	0	174	81	53	36	0	170	24	322	24	0	370	809
04:30 PM	33	59	22	0	114	12	136	26	0	174	87	49	25	0	161	20	354	25	0	399	848
04:45 PM	23	56	33	0	112	15	119	27	0	161	75	51	39	0	165	33	327	24	0	384	822
<b>Total</b>	<b>117</b>	<b>215</b>	<b>97</b>	<b>0</b>	<b>429</b>	<b>35</b>	<b>492</b>	<b>120</b>	<b>0</b>	<b>647</b>	<b>298</b>	<b>215</b>	<b>146</b>	<b>0</b>	<b>659</b>	<b>110</b>	<b>1290</b>	<b>87</b>	<b>0</b>	<b>1487</b>	<b>3222</b>
05:00 PM	25	76	20	0	121	12	137	39	0	188	87	50	45	0	182	11	299	26	0	336	827
05:15 PM	29	71	19	0	119	10	148	27	0	185	96	69	41	0	206	23	311	18	0	352	862
05:30 PM	28	73	30	0	131	4	148	34	0	186	80	53	38	0	171	14	270	31	0	315	803
05:45 PM	22	54	23	0	99	5	137	23	0	165	90	58	38	0	186	12	306	13	0	331	781
<b>Total</b>	<b>104</b>	<b>274</b>	<b>92</b>	<b>0</b>	<b>470</b>	<b>31</b>	<b>570</b>	<b>123</b>	<b>0</b>	<b>724</b>	<b>353</b>	<b>230</b>	<b>162</b>	<b>0</b>	<b>745</b>	<b>60</b>	<b>1186</b>	<b>88</b>	<b>0</b>	<b>1334</b>	<b>3273</b>
Grand Total	221	489	189	0	899	66	1062	243	0	1371	651	445	308	0	1404	170	2476	175	0	2821	6495
Apprch %	24.6	54.4	21	0		4.8	77.5	17.7	0		46.4	31.7	21.9	0		6	87.8	6.2	0		
Total %	3.4	7.5	2.9	0	13.8	1	16.4	3.7	0	21.1	10	6.9	4.7	0	21.6	2.6	38.1	2.7	0	43.4	

Start Time	BAY RD Southbound					UNIVERSITY AVE Westbound					BAY RD Northbound					UNIVERSITY AVE Eastbound					Int. Total
	Right	Thru	Left	Peds	App. Total	Right	Thru	Left	Peds	App. Total	Right	Thru	Left	Peds	App. Total	Right	Thru	Left	Peds	App. Total	
Peak Hour Analysis From 04:00 PM to 05:45 PM - Peak 1 of 1																					
Peak Hour for Entire Intersection Begins at 04:30 PM																					
04:30 PM	33	59	22	0	114	12	136	26	0	174	87	49	25	0	161	20	354	25	0	399	848
04:45 PM	23	56	33	0	112	15	119	27	0	161	75	51	39	0	165	33	327	24	0	384	822
05:00 PM	25	76	20	0	121	12	137	39	0	188	87	50	45	0	182	11	299	26	0	336	827
05:15 PM	29	71	19	0	119	10	148	27	0	185	96	69	41	0	206	23	311	18	0	352	862
Total Volume	110	262	94	0	466	49	540	119	0	708	345	219	150	0	714	87	1291	93	0	1471	3359
% App. Total																					
PHF	.833	.862	.712	.000	.963	.817	.912	.763	.000	.941	.898	.793	.833	.000	.867	.659	.912	.894	.000	.922	.974

# Traffic Data Service

Campbell, CA  
 (408) 377-2988  
 tdsbay@cs.com

File Name : 4PM FINAL  
 Site Code : 00000004  
 Start Date : 11/9/2010  
 Page No : 2

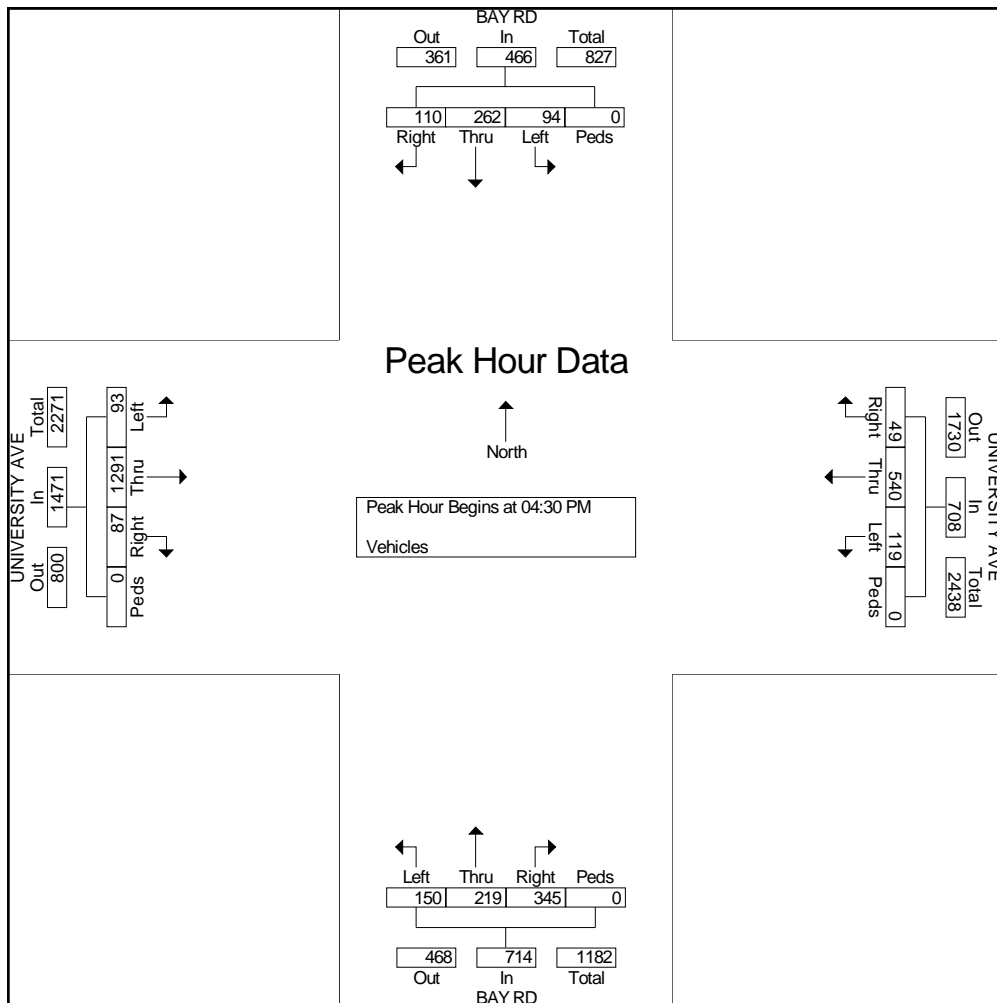

# Traffic Data Service

Campbell, CA  
(408) 377-2988  
tdsbay@cs.com

File Name : 5AM FINAL  
Site Code : 00000005  
Start Date : 11/9/2010  
Page No : 1

### Groups Printed- Vehicles

Start Time	RUNNYMEDE ST Southbound					UNIVERSITY AVE Westbound					RUNNYMEDE ST Northbound					UNIVERSITY AVE Eastbound					Int. Total
	Right	Thru	Left	Peds	App. Total	Right	Thru	Left	Peds	App. Total	Right	Thru	Left	Peds	App. Total	Right	Thru	Left	Peds	App. Total	
07:00 AM	1	8	2	0	11	6	275	12	0	293	8	13	6	0	27	8	86	0	0	94	425
07:15 AM	3	21	3	0	27	15	309	30	0	354	5	33	18	0	56	19	125	4	0	148	585
07:30 AM	0	17	7	0	24	21	334	21	0	376	2	37	14	0	53	17	132	2	0	151	604
07:45 AM	5	22	5	0	32	18	301	27	0	346	3	22	12	0	37	14	153	3	0	170	585
<b>Total</b>	<b>9</b>	<b>68</b>	<b>17</b>	<b>0</b>	<b>94</b>	<b>60</b>	<b>1219</b>	<b>90</b>	<b>0</b>	<b>1369</b>	<b>18</b>	<b>105</b>	<b>50</b>	<b>0</b>	<b>173</b>	<b>58</b>	<b>496</b>	<b>9</b>	<b>0</b>	<b>563</b>	<b>2199</b>
08:00 AM	21	9	2	0	32	12	286	23	0	321	3	28	10	0	41	9	168	7	0	184	578
08:15 AM	30	11	2	0	43	10	325	17	0	352	4	18	11	0	33	8	173	6	0	187	615
08:30 AM	19	10	2	0	31	8	328	25	0	361	2	13	10	0	25	5	136	1	0	142	559
08:45 AM	6	13	3	0	22	6	319	22	0	347	2	14	16	0	32	8	128	0	0	136	537
<b>Total</b>	<b>76</b>	<b>43</b>	<b>9</b>	<b>0</b>	<b>128</b>	<b>36</b>	<b>1258</b>	<b>87</b>	<b>0</b>	<b>1381</b>	<b>11</b>	<b>73</b>	<b>47</b>	<b>0</b>	<b>131</b>	<b>30</b>	<b>605</b>	<b>14</b>	<b>0</b>	<b>649</b>	<b>2289</b>
<b>Grand Total</b>	<b>85</b>	<b>111</b>	<b>26</b>	<b>0</b>	<b>222</b>	<b>96</b>	<b>2477</b>	<b>177</b>	<b>0</b>	<b>2750</b>	<b>29</b>	<b>178</b>	<b>97</b>	<b>0</b>	<b>304</b>	<b>88</b>	<b>1101</b>	<b>23</b>	<b>0</b>	<b>1212</b>	<b>4488</b>
Apprch %	38.3	50	11.7	0		3.5	90.1	6.4	0		9.5	58.6	31.9	0		7.3	90.8	1.9	0		
Total %	1.9	2.5	0.6	0	4.9	2.1	55.2	3.9	0	61.3	0.6	4	2.2	0	6.8	2	24.5	0.5	0	27	

Start Time	RUNNYMEDE ST Southbound					UNIVERSITY AVE Westbound					RUNNYMEDE ST Northbound					UNIVERSITY AVE Eastbound					Int. Total
	Right	Thru	Left	Peds	App. Total	Right	Thru	Left	Peds	App. Total	Right	Thru	Left	Peds	App. Total	Right	Thru	Left	Peds	App. Total	
Peak Hour Analysis From 07:00 AM to 08:45 AM - Peak 1 of 1																					
Peak Hour for Entire Intersection Begins at 07:30 AM																					
07:30 AM	0	17	7	0	24	21	334	21	0	376	2	37	14	0	53	17	132	2	0	151	604
07:45 AM	5	22	5	0	32	18	301	27	0	346	3	22	12	0	37	14	153	3	0	170	585
08:00 AM	21	9	2	0	32	12	286	23	0	321	3	28	10	0	41	9	168	7	0	184	578
08:15 AM	30	11	2	0	43	10	325	17	0	352	4	18	11	0	33	8	173	6	0	187	615
<b>Total Volume</b>	<b>56</b>	<b>59</b>	<b>16</b>	<b>0</b>	<b>131</b>	<b>61</b>	<b>1246</b>	<b>88</b>	<b>0</b>	<b>1395</b>	<b>12</b>	<b>105</b>	<b>47</b>	<b>0</b>	<b>164</b>	<b>48</b>	<b>626</b>	<b>18</b>	<b>0</b>	<b>692</b>	<b>2382</b>
% App. Total																					
PHF	.467	.670	.571	.000	.762	.726	.933	.815	.000	.928	.750	.709	.839	.000	.774	.706	.905	.643	.000	.925	.968

# Traffic Data Service

Campbell, CA  
 (408) 377-2988  
 tdsbay@cs.com

File Name : 5AM FINAL  
 Site Code : 00000005  
 Start Date : 11/9/2010  
 Page No : 2

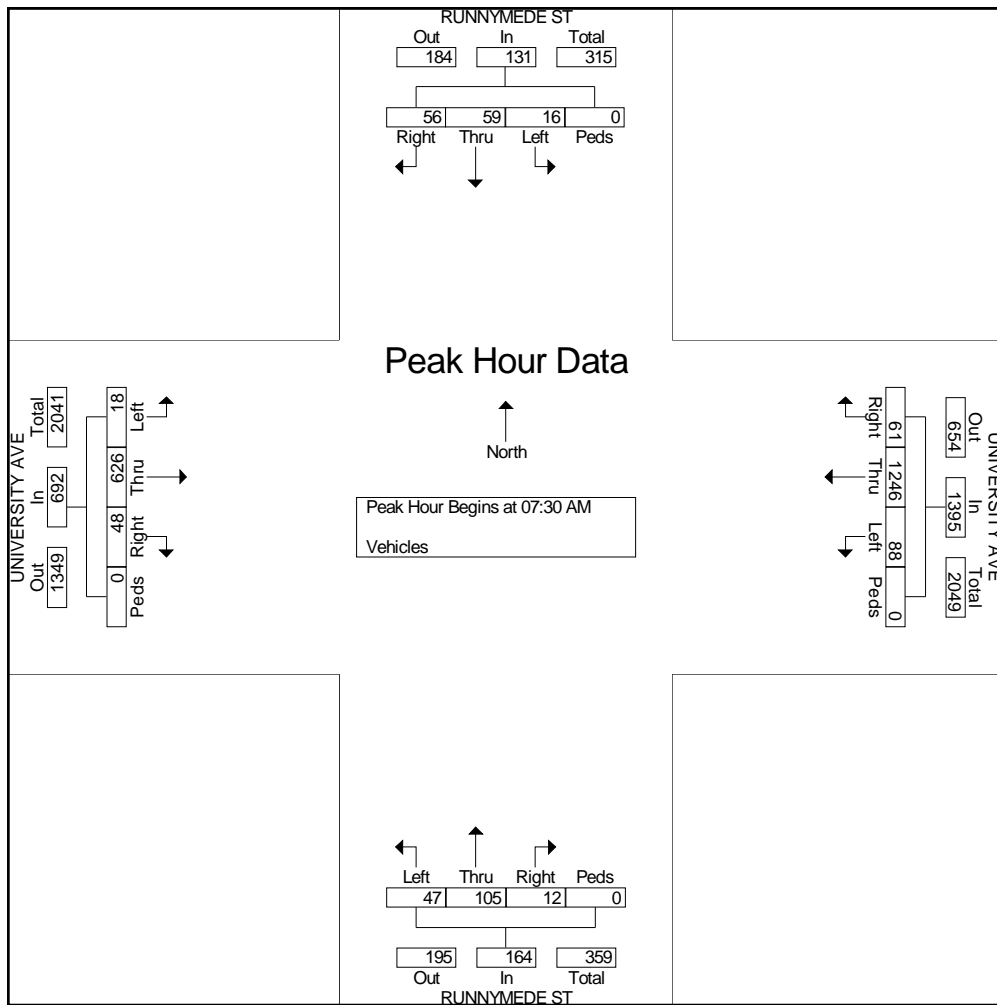

# Traffic Data Service

Campbell, CA  
(408) 377-2988  
tdsbay@cs.com

File Name : 5PM FINAL  
Site Code : 00000005  
Start Date : 11/9/2010  
Page No : 1

### Groups Printed- Vehicles

Start Time	RUNNYMEDE ST Southbound					UNIVERSITY AVE Westbound					RUNNYMEDE ST Northbound					UNIVERSITY AVE Eastbound					Int. Total
	Right	Thru	Left	Peds	App. Total	Right	Thru	Left	Peds	App. Total	Right	Thru	Left	Peds	App. Total	Right	Thru	Left	Peds	App. Total	
04:00 PM	7	19	3	0	29	9	179	9	0	197	12	13	7	0	32	26	313	4	0	343	601
04:15 PM	9	16	1	0	26	4	151	6	0	161	27	15	13	0	55	20	329	5	0	354	596
04:30 PM	7	16	7	0	30	4	168	11	0	183	17	23	22	0	62	24	323	11	0	358	633
04:45 PM	14	15	5	0	34	0	182	6	0	188	12	23	20	0	55	21	317	3	0	341	618
<b>Total</b>	<b>37</b>	<b>66</b>	<b>16</b>	<b>0</b>	<b>119</b>	<b>17</b>	<b>680</b>	<b>32</b>	<b>0</b>	<b>729</b>	<b>68</b>	<b>74</b>	<b>62</b>	<b>0</b>	<b>204</b>	<b>91</b>	<b>1282</b>	<b>23</b>	<b>0</b>	<b>1396</b>	<b>2448</b>
05:00 PM	3	18	2	0	23	6	194	15	0	215	10	38	21	0	69	12	312	9	0	333	640
05:15 PM	6	23	4	0	33	5	194	9	0	208	19	21	18	0	58	20	335	13	0	368	667
05:30 PM	4	20	6	0	30	6	223	14	0	243	18	27	19	0	64	25	300	4	0	329	666
05:45 PM	5	25	8	0	38	7	149	9	0	165	18	23	23	0	64	17	292	7	0	316	583
<b>Total</b>	<b>18</b>	<b>86</b>	<b>20</b>	<b>0</b>	<b>124</b>	<b>24</b>	<b>760</b>	<b>47</b>	<b>0</b>	<b>831</b>	<b>65</b>	<b>109</b>	<b>81</b>	<b>0</b>	<b>255</b>	<b>74</b>	<b>1239</b>	<b>33</b>	<b>0</b>	<b>1346</b>	<b>2556</b>
Grand Total	55	152	36	0	243	41	1440	79	0	1560	133	183	143	0	459	165	2521	56	0	2742	5004
Apprch %	22.6	62.6	14.8	0		2.6	92.3	5.1	0		2.7	39.9	31.2	0		6	91.9	2	0		
Total %	1.1	3	0.7	0	4.9	0.8	28.8	1.6	0	31.2	2.7	3.7	2.9	0	9.2	3.3	50.4	1.1	0	54.8	

Start Time	RUNNYMEDE ST Southbound					UNIVERSITY AVE Westbound					RUNNYMEDE ST Northbound					UNIVERSITY AVE Eastbound					Int. Total
	Right	Thru	Left	Peds	App. Total	Right	Thru	Left	Peds	App. Total	Right	Thru	Left	Peds	App. Total	Right	Thru	Left	Peds	App. Total	
Peak Hour Analysis From 04:00 PM to 05:45 PM - Peak 1 of 1																					
Peak Hour for Entire Intersection Begins at 04:45 PM																					
04:45 PM	14	15	5	0	34	0	182	6	0	188	12	23	20	0	55	21	317	3	0	341	618
05:00 PM	3	18	2	0	23	6	194	15	0	215	10	38	21	0	69	12	312	9	0	333	640
05:15 PM	6	23	4	0	33	5	194	9	0	208	19	21	18	0	58	20	335	13	0	368	667
05:30 PM	4	20	6	0	30	6	223	14	0	243	18	27	19	0	64	25	300	4	0	329	666
Total Volume	27	76	17	0	120	17	793	44	0	854	59	109	78	0	246	78	1264	29	0	1371	2591
% App. Total																					
PHF	.482	.826	.708	.000	.882	.708	.889	.733	.000	.879	.776	.717	.929	.000	.891	.780	.943	.558	.000	.931	.971

# Traffic Data Service

Campbell, CA  
 (408) 377-2988  
 tdsbay@cs.com

File Name : 5PM FINAL  
 Site Code : 00000005  
 Start Date : 11/9/2010  
 Page No : 2

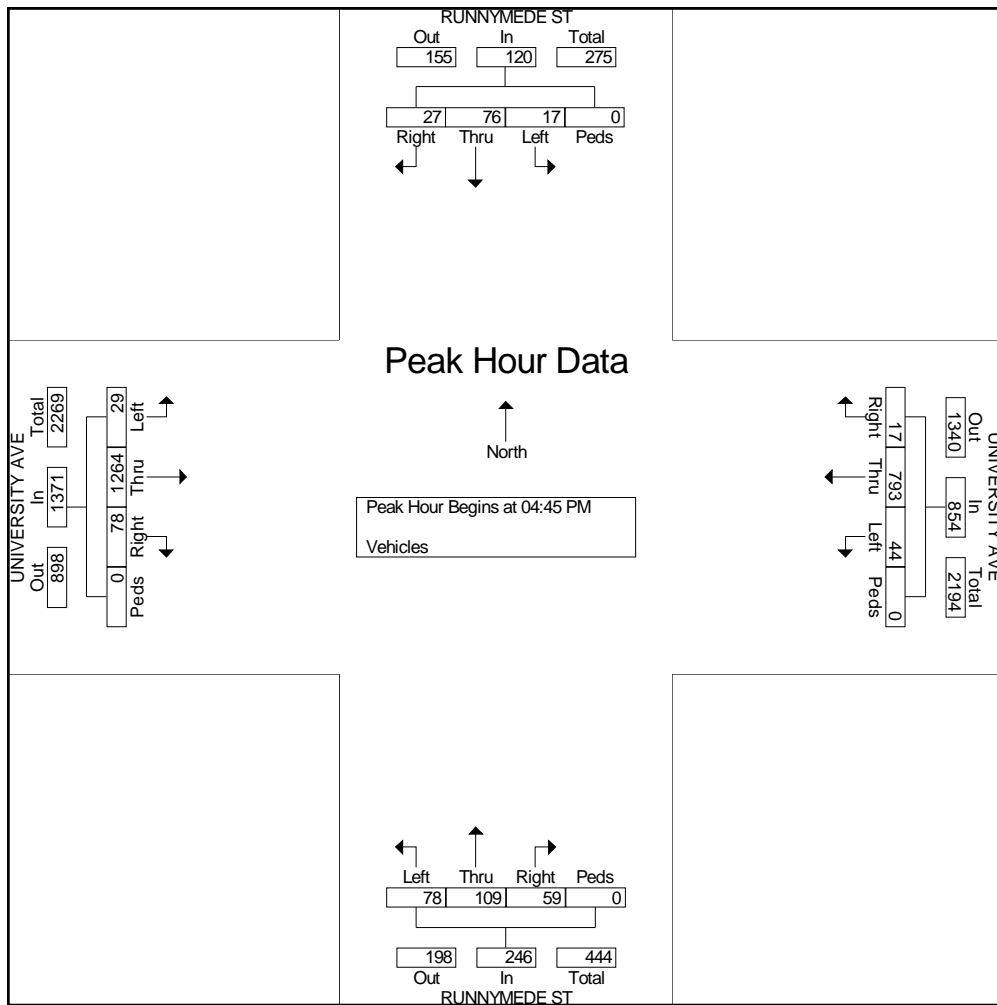

# All Traffic Data

(916) 771-8700

CITY OF MENLO PARK

File Name : 11-7274-003 UNIVERSITY-BELL

Site Code : 00000000

Start Date : 6/8/2011

Page No : 1

## Groups Printed- Unshifted

Start Time	UNIVERSITY AVE. Southbound				BELL ST. Westbound				UNIVERSITY AVE. Northbound				BELL ST. Eastbound				Int. Total
	Left	Thru	Right	App. Total	Left	Thru	Right	App. Total	Left	Thru	Right	App. Total	Left	Thru	Right	App. Total	
07:00	2	223	6	231	6	14	2	22	0	148	2	150	0	5	3	8	411
07:15	6	241	5	252	8	15	3	26	2	167	3	172	2	9	2	13	463
07:30	5	256	6	267	9	17	3	29	2	176	5	183	1	8	3	12	491
07:45	6	271	8	285	13	21	4	38	3	189	6	198	2	13	4	19	540
Total	19	991	25	1035	36	67	12	115	7	680	16	703	5	35	12	52	1905
08:00	4	221	2	227	7	16	3	26	2	192	3	197	3	15	4	22	472
08:15	1	304	7	312	3	25	0	28	6	141	9	156	0	15	2	17	513
08:30	5	337	7	349	5	7	3	15	4	135	8	147	2	9	2	13	524
08:45	5	368	8	381	3	11	3	17	3	146	4	153	2	4	3	9	560
Total	15	1230	24	1269	18	59	9	86	15	614	24	653	7	43	11	61	2069
16:00	4	166	3	173	9	13	18	40	5	247	14	266	5	11	7	23	502
16:15	5	198	5	208	17	9	6	32	7	286	7	300	5	13	9	27	567
16:30	10	203	7	220	15	20	11	46	13	352	16	381	0	18	9	27	674
16:45	8	187	5	200	15	19	14	48	9	319	23	351	8	16	4	28	627
Total	27	754	20	801	56	61	49	166	34	1204	60	1298	18	58	29	105	2370
17:00	9	184	5	198	17	24	6	47	9	335	27	371	2	19	3	24	640
17:15	10	213	5	228	13	20	7	40	11	316	21	348	1	15	6	22	638
17:30	6	203	6	215	20	21	9	50	4	306	21	331	2	15	3	20	616
17:45	9	187	9	205	19	15	13	47	4	304	17	325	2	13	9	24	601
Total	34	787	25	846	69	80	35	184	28	1261	86	1375	7	62	21	90	2495
Grand Total	95	3762	94	3951	179	267	105	551	84	3759	186	4029	37	198	73	308	8839
Apprch %	2.4	95.2	2.4		32.5	48.5	19.1		2.1	93.3	4.6		12	64.3	23.7		
Total %	1.1	42.6	1.1	44.7	2	3	1.2	6.2	1	42.5	2.1	45.6	0.4	2.2	0.8	3.5	



# All Traffic Data

(916) 771-8700

CITY OF MENLO PARK

File Name : 11-7274-003 UNIVERSITY-BELL

Site Code : 00000000

Start Date : 6/8/2011

Page No : 2

Start Time	UNIVERSITY AVE. Southbound				BELL ST. Westbound				UNIVERSITY AVE. Northbound				BELL ST. Eastbound				Int. Total
	Left	Thru	Right	App. Total	Left	Thru	Right	App. Total	Left	Thru	Right	App. Total	Left	Thru	Right	App. Total	
Peak Hour Analysis From 07:00 to 08:45 - Peak 1 of 1																	
Peak Hour for Entire Intersection Begins at 08:00																	
08:00	4	221	2	227	7	16	3	26	2	192	3	197	3	15	4	22	472
08:15	1	304	7	312	3	25	0	28	6	141	9	156	0	15	2	17	513
08:30	5	337	7	349	5	7	3	15	4	135	8	147	2	9	2	13	524
08:45	5	368	8	381	3	11	3	17	3	146	4	153	2	4	3	9	560
Total Volume	15	1230	24	1269	18	59	9	86	15	614	24	653	7	43	11	61	2069
% App. Total	1.2	96.9	1.9		20.9	68.6	10.5		2.3	94	3.7		11.5	70.5	18		
PHF	.750	.836	.750	.833	.643	.590	.750	.768	.625	.799	.667	.829	.583	.717	.688	.693	.924

# All Traffic Data

(916) 771-8700

CITY OF MENLO PARK

File Name : 11-7274-003 UNIVERSITY-BELL

Site Code : 00000000

Start Date : 6/8/2011

Page No : 3

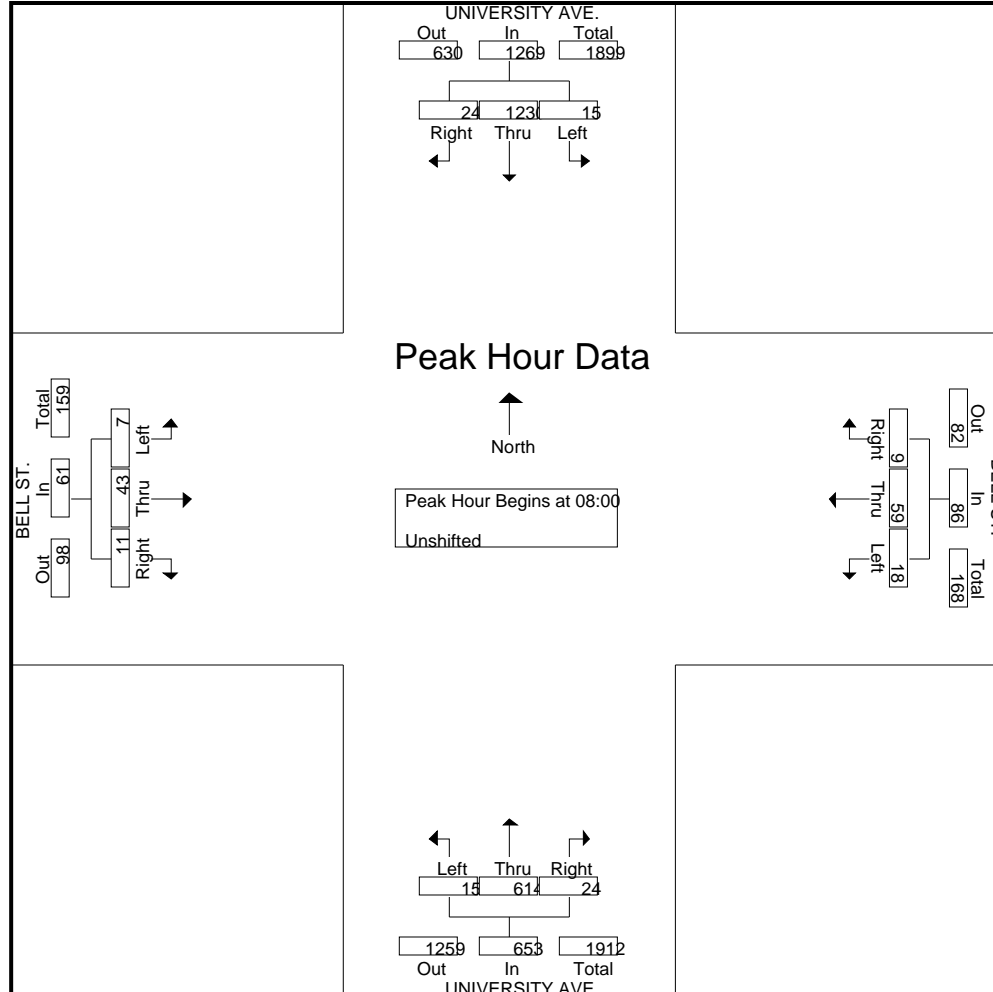

# All Traffic Data

(916) 771-8700

CITY OF MENLO PARK

File Name : 11-7274-003 UNIVERSITY-BELL

Site Code : 00000000

Start Date : 6/8/2011

Page No : 4

Start Time	UNIVERSITY AVE. Southbound				BELL ST. Westbound				UNIVERSITY AVE. Northbound				BELL ST. Eastbound				Int. Total
	Left	Thru	Right	App. Total	Left	Thru	Right	App. Total	Left	Thru	Right	App. Total	Left	Thru	Right	App. Total	
Peak Hour Analysis From 16:00 to 17:45 - Peak 1 of 1																	
Peak Hour for Entire Intersection Begins at 16:30																	
16:30	<b>10</b>	203	<b>7</b>	220	15	20	11	46	<b>13</b>	<b>352</b>	16	<b>381</b>	0	18	<b>9</b>	27	<b>674</b>
16:45	8	187	5	200	15	19	<b>14</b>	<b>48</b>	9	319	23	351	<b>8</b>	16	4	<b>28</b>	627
17:00	9	184	5	198	<b>17</b>	<b>24</b>	6	47	9	335	<b>27</b>	371	2	<b>19</b>	3	24	640
17:15	10	<b>213</b>	5	<b>228</b>	13	20	7	40	11	316	21	348	1	15	6	22	638
Total Volume	37	787	22	846	60	83	38	181	42	1322	87	1451	11	68	22	101	2579
% App. Total	4.4	93	2.6		33.1	45.9	21		2.9	91.1	6		10.9	67.3	21.8		
PHF	.925	.924	.786	.928	.882	.865	.679	.943	.808	.939	.806	.952	.344	.895	.611	.902	.957

# All Traffic Data

(916) 771-8700

CITY OF MENLO PARK

File Name : 11-7274-003 UNIVERSITY-BELL

Site Code : 00000000

Start Date : 6/8/2011

Page No : 5

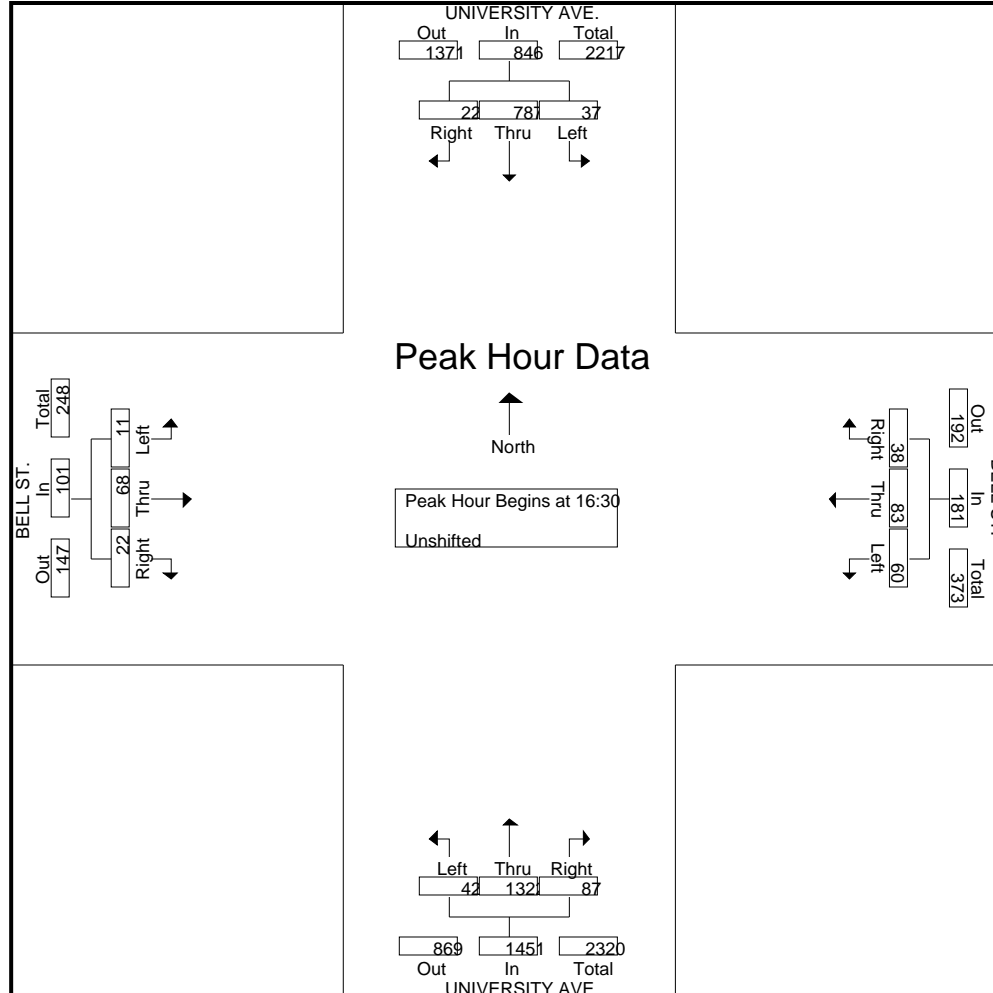

# Traffic Data Service

Campbell, CA  
(408) 377-2988  
tdsbay@cs.com

File Name : 6AM FINAL  
Site Code : 00000006  
Start Date : 11/9/2010  
Page No : 1

### Groups Printed- Vehicles

Start Time	DONOHOE ST Southbound					UNIVERSITY AVE Westbound					DONOHOE ST Northbound					UNIVERSITY AVE Eastbound					Int. Total
	Right	Thru	Left	Peds	App. Total	Right	Thru	Left	Peds	App. Total	Right	Thru	Left	Peds	App. Total	Right	Thru	Left	Peds	App. Total	
07:00 AM	66	22	5	0	93	21	239	15	0	275	49	113	50	0	212	58	32	23	0	113	693
07:15 AM	74	27	5	0	106	20	293	6	0	319	70	122	92	0	284	82	66	20	0	168	877
07:30 AM	120	36	2	0	158	23	294	8	0	325	67	122	86	0	275	58	87	22	0	167	925
07:45 AM	102	28	2	0	132	12	284	8	0	304	76	109	119	0	304	75	93	24	0	192	932
<b>Total</b>	<b>362</b>	<b>113</b>	<b>14</b>	<b>0</b>	<b>489</b>	<b>76</b>	<b>1110</b>	<b>37</b>	<b>0</b>	<b>1223</b>	<b>262</b>	<b>466</b>	<b>347</b>	<b>0</b>	<b>1075</b>	<b>273</b>	<b>278</b>	<b>89</b>	<b>0</b>	<b>640</b>	<b>3427</b>
08:00 AM	83	30	3	0	116	14	306	15	0	335	79	107	90	0	276	73	87	45	0	205	932
08:15 AM	78	30	4	0	112	19	321	18	0	358	106	99	67	0	272	77	85	26	0	188	930
08:30 AM	52	30	5	0	87	28	306	14	0	348	85	106	57	0	248	80	50	22	0	152	835
08:45 AM	61	32	8	0	101	22	277	10	0	309	76	107	55	0	238	59	46	13	0	118	766
<b>Total</b>	<b>274</b>	<b>122</b>	<b>20</b>	<b>0</b>	<b>416</b>	<b>83</b>	<b>1210</b>	<b>57</b>	<b>0</b>	<b>1350</b>	<b>346</b>	<b>419</b>	<b>269</b>	<b>0</b>	<b>1034</b>	<b>289</b>	<b>268</b>	<b>106</b>	<b>0</b>	<b>663</b>	<b>3463</b>
Grand Total	636	235	34	0	905	159	2320	94	0	2573	608	885	616	0	2109	562	546	195	0	1303	6890
Apprch %	70.3	26	3.8	0		6.2	90.2	3.7	0		28.8	42	29.2	0		43.1	41.9	15	0		
Total %	9.2	3.4	0.5	0	13.1	2.3	33.7	1.4	0	37.3	8.8	12.8	8.9	0	30.6	8.2	7.9	2.8	0	18.9	

Start Time	DONOHOE ST Southbound					UNIVERSITY AVE Westbound					DONOHOE ST Northbound					UNIVERSITY AVE Eastbound					Int. Total
	Right	Thru	Left	Peds	App. Total	Right	Thru	Left	Peds	App. Total	Right	Thru	Left	Peds	App. Total	Right	Thru	Left	Peds	App. Total	
Peak Hour Analysis From 07:00 AM to 08:45 AM - Peak 1 of 1																					
Peak Hour for Entire Intersection Begins at 07:30 AM																					
07:30 AM	120	36	2	0	158	23	294	8	0	325	67	122	86	0	275	58	87	22	0	167	925
07:45 AM	102	28	2	0	132	12	284	8	0	304	76	109	119	0	304	75	93	24	0	192	932
08:00 AM	83	30	3	0	116	14	306	15	0	335	79	107	90	0	276	73	87	45	0	205	932
08:15 AM	78	30	4	0	112	19	321	18	0	358	106	99	67	0	272	77	85	26	0	188	930
Total Volume	383	124	11	0	518	68	1205	49	0	1322	328	437	362	0	1127	283	352	117	0	752	3719
% App. Total																					
PHF	.798	.861	.688	.000	.820	.739	.938	.681	.000	.923	.774	.895	.761	.000	.927	.919	.946	.650	.000	.917	.998

# Traffic Data Service

Campbell, CA  
 (408) 377-2988  
 tdsbay@cs.com

File Name : 6AM FINAL  
 Site Code : 00000006  
 Start Date : 11/9/2010  
 Page No : 2

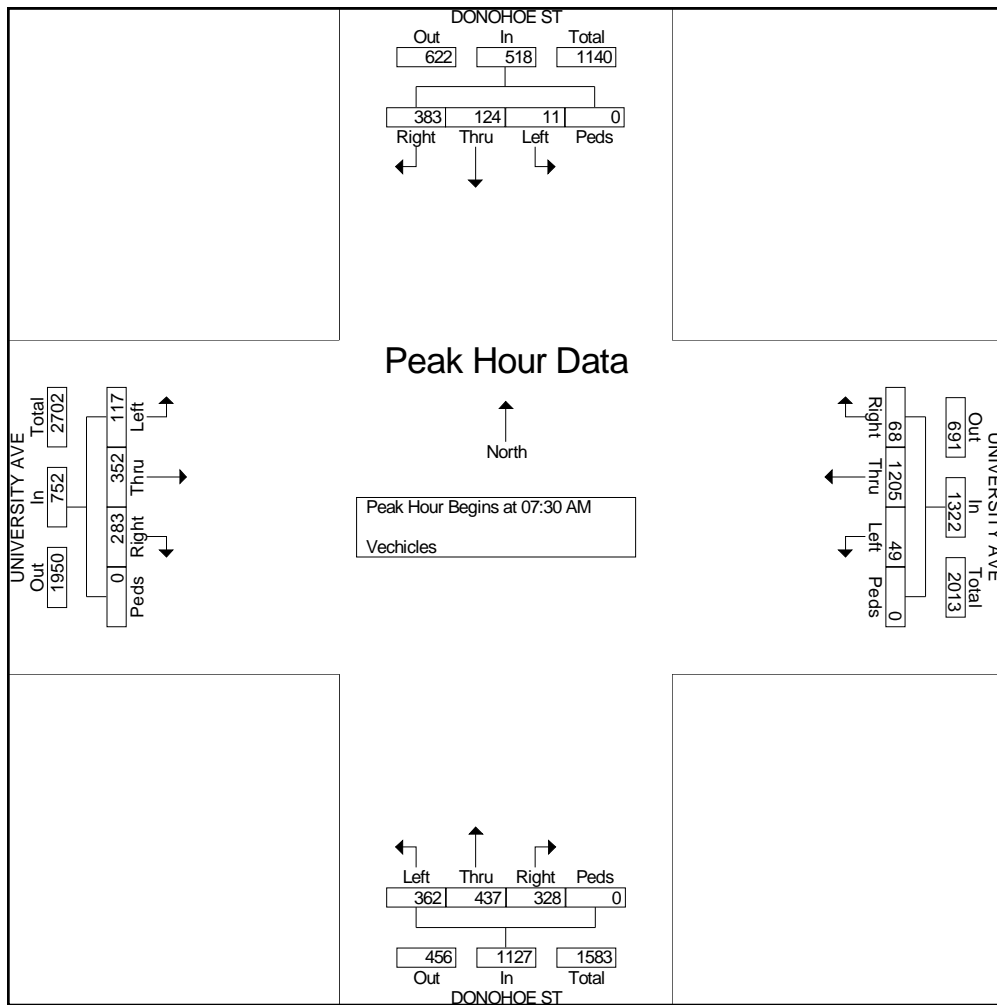

# Traffic Data Service

Campbell, CA  
(408) 377-2988  
tdsbay@cs.com

File Name : 6PM FINAL  
Site Code : 00000006  
Start Date : 11/9/2010  
Page No : 1

### Groups Printed- Vehicles

Start Time	DONOHOE ST Southbound					UNIVERSITY AVE Westbound					DONOHOE ST Northbound					UNIVERSITY AVE Eastbound					Int. Total
	Right	Thru	Left	Peds	App. Total	Right	Thru	Left	Peds	App. Total	Right	Thru	Left	Peds	App. Total	Right	Thru	Left	Peds	App. Total	
04:00 PM	29	27	13	0	69	32	168	14	0	214	158	104	73	0	335	113	187	37	0	337	955
04:15 PM	55	38	12	0	105	46	144	14	0	204	168	122	71	0	361	117	196	60	0	373	1043
04:30 PM	59	38	5	0	102	46	144	23	0	213	175	121	59	0	355	104	193	55	0	352	1022
04:45 PM	49	53	8	0	110	39	163	30	0	232	154	129	85	0	368	125	191	55	0	371	1081
<b>Total</b>	<b>192</b>	<b>156</b>	<b>38</b>	<b>0</b>	<b>386</b>	<b>163</b>	<b>619</b>	<b>81</b>	<b>0</b>	<b>863</b>	<b>655</b>	<b>476</b>	<b>288</b>	<b>0</b>	<b>1419</b>	<b>459</b>	<b>767</b>	<b>207</b>	<b>0</b>	<b>1433</b>	<b>4101</b>
05:00 PM	57	35	4	0	96	48	145	23	0	216	153	117	70	0	340	129	188	73	0	390	1042
05:15 PM	69	42	10	0	121	38	185	32	0	255	150	131	65	0	346	146	206	49	0	401	1123
05:30 PM	49	45	10	0	104	48	170	30	0	248	142	108	95	0	345	140	199	40	0	379	1076
05:45 PM	32	48	7	0	87	25	151	27	0	203	144	95	76	0	315	135	157	46	0	338	943
<b>Total</b>	<b>207</b>	<b>170</b>	<b>31</b>	<b>0</b>	<b>408</b>	<b>159</b>	<b>651</b>	<b>112</b>	<b>0</b>	<b>922</b>	<b>589</b>	<b>451</b>	<b>306</b>	<b>0</b>	<b>1346</b>	<b>550</b>	<b>750</b>	<b>208</b>	<b>0</b>	<b>1508</b>	<b>4184</b>
<b>Grand Total</b>	<b>399</b>	<b>326</b>	<b>69</b>	<b>0</b>	<b>794</b>	<b>322</b>	<b>1270</b>	<b>193</b>	<b>0</b>	<b>1785</b>	<b>1244</b>	<b>927</b>	<b>594</b>	<b>0</b>	<b>2765</b>	<b>1009</b>	<b>1517</b>	<b>415</b>	<b>0</b>	<b>2941</b>	<b>8285</b>
<b>Apprch %</b>	<b>50.3</b>	<b>41.1</b>	<b>8.7</b>	<b>0</b>		<b>18</b>	<b>71.1</b>	<b>10.8</b>	<b>0</b>		<b>45</b>	<b>33.5</b>	<b>21.5</b>	<b>0</b>		<b>34.3</b>	<b>51.6</b>	<b>14.1</b>	<b>0</b>		
<b>Total %</b>	<b>4.8</b>	<b>3.9</b>	<b>0.8</b>	<b>0</b>	<b>9.6</b>	<b>3.9</b>	<b>15.3</b>	<b>2.3</b>	<b>0</b>	<b>21.5</b>	<b>15</b>	<b>11.2</b>	<b>7.2</b>	<b>0</b>	<b>33.4</b>	<b>12.2</b>	<b>18.3</b>	<b>5</b>	<b>0</b>	<b>35.5</b>	

Start Time	DONOHOE ST Southbound					UNIVERSITY AVE Westbound					DONOHOE ST Northbound					UNIVERSITY AVE Eastbound					Int. Total
	Right	Thru	Left	Peds	App. Total	Right	Thru	Left	Peds	App. Total	Right	Thru	Left	Peds	App. Total	Right	Thru	Left	Peds	App. Total	
Peak Hour Analysis From 04:00 PM to 05:45 PM - Peak 1 of 1																					
Peak Hour for Entire Intersection Begins at 04:45 PM																					
04:45 PM	49	53	8	0	110	39	163	30	0	232	154	129	85	0	368	125	191	55	0	371	1081
05:00 PM	57	35	4	0	96	48	145	23	0	216	153	117	70	0	340	129	188	73	0	390	1042
05:15 PM	69	42	10	0	121	38	185	32	0	255	150	131	65	0	346	146	206	49	0	401	1123
05:30 PM	49	45	10	0	104	48	170	30	0	248	142	108	95	0	345	140	199	40	0	379	1076
<b>Total Volume</b>	<b>224</b>	<b>175</b>	<b>32</b>	<b>0</b>	<b>431</b>	<b>173</b>	<b>663</b>	<b>115</b>	<b>0</b>	<b>951</b>	<b>599</b>	<b>485</b>	<b>315</b>	<b>0</b>	<b>1399</b>	<b>540</b>	<b>784</b>	<b>217</b>	<b>0</b>	<b>1541</b>	<b>4322</b>
<b>% App. Total</b>	<b>52</b>	<b>40.6</b>	<b>7.4</b>	<b>0</b>		<b>18.2</b>	<b>69.7</b>	<b>12.1</b>	<b>0</b>		<b>42.8</b>	<b>34.7</b>	<b>22.5</b>	<b>0</b>		<b>35</b>	<b>50.9</b>	<b>14.1</b>	<b>0</b>		
<b>PHF</b>	<b>.812</b>	<b>.825</b>	<b>.800</b>	<b>.000</b>	<b>.890</b>	<b>.901</b>	<b>.896</b>	<b>.898</b>	<b>.000</b>	<b>.932</b>	<b>.972</b>	<b>.926</b>	<b>.829</b>	<b>.000</b>	<b>.950</b>	<b>.925</b>	<b>.951</b>	<b>.743</b>	<b>.000</b>	<b>.961</b>	<b>.962</b>

# Traffic Data Service

Campbell, CA  
 (408) 377-2988  
 tdsbay@cs.com

File Name : 6PM FINAL  
 Site Code : 00000006  
 Start Date : 11/9/2010  
 Page No : 2

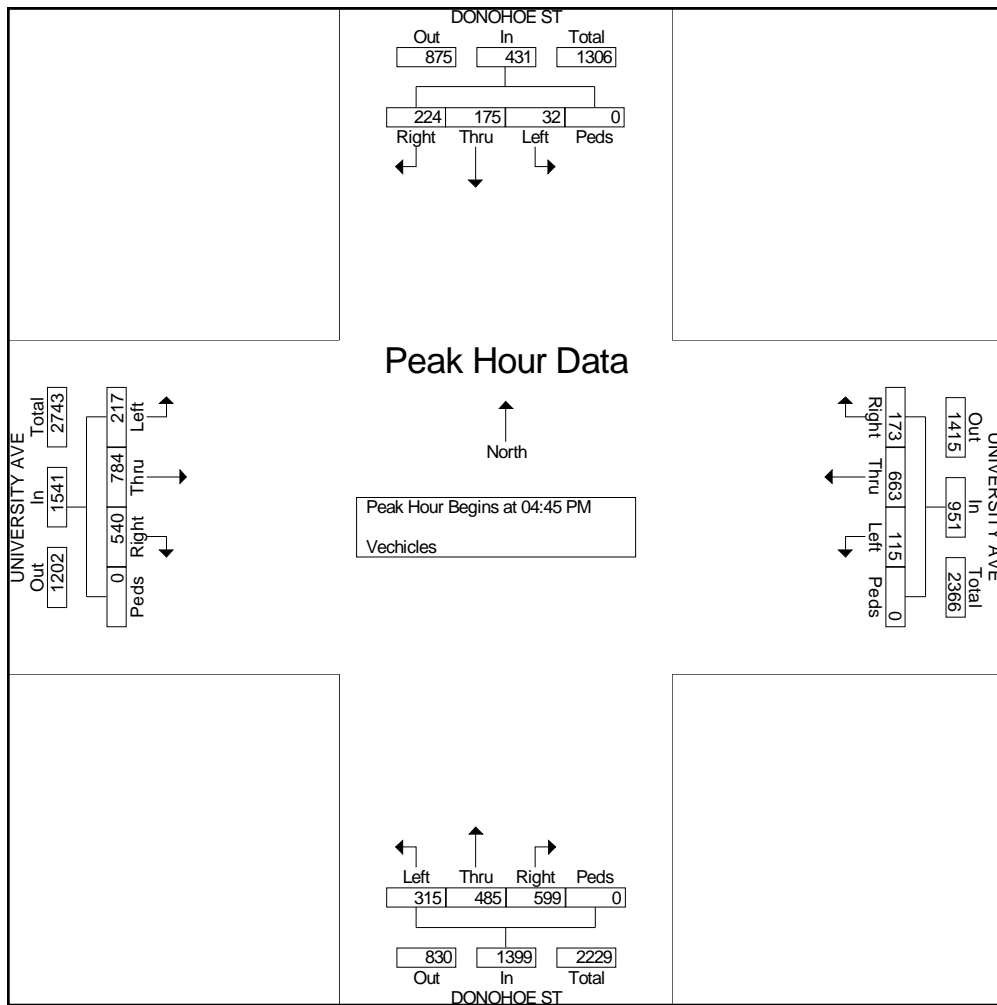



# All Traffic Data

(916) 771-8700

CITY OF MENLO PARK

File Name : 11-7274-001 CAPITOL-DONOHUE

Site Code : 00000000

Start Date : 6/8/2011

Page No : 1

## Groups Printed- Unshifted

Start Time	CAPITOL AVE. Southbound				DONOHUE ST. Westbound				US-101 NB OFF RAMP Northbound				DONOHUE ST. Eastbound				Int. Total
	Left	Thru	Right	App. Total	Left	Thru	Right	App. Total	Left	Thru	Right	App. Total	Left	Thru	Right	App. Total	
07:00	0	0	5	5	0	158	1	159	86	0	43	129	0	123	0	123	416
07:15	0	0	10	10	0	178	1	179	75	0	28	103	0	116	0	116	408
07:30	0	0	22	22	0	232	3	235	87	0	48	135	0	109	0	109	501
07:45	0	0	42	42	0	214	1	215	87	0	27	114	0	119	0	119	490
Total	0	0	79	79	0	782	6	788	335	0	146	481	0	467	0	467	1815
08:00	0	0	28	28	0	206	1	207	104	0	24	128	0	124	0	124	487
08:15	0	0	21	21	0	185	3	188	87	0	41	128	0	99	0	99	436
08:30	0	0	27	27	0	185	1	186	96	0	32	128	0	138	0	138	479
08:45	0	0	14	14	0	136	1	137	87	0	29	116	0	110	0	110	377
Total	0	0	90	90	0	712	6	718	374	0	126	500	0	471	0	471	1779
16:00	0	0	3	3	0	259	6	265	125	0	44	169	0	184	0	184	621
16:15	0	0	1	1	0	218	1	219	185	0	64	249	0	172	0	172	641
16:30	0	0	4	4	0	195	6	201	188	0	65	253	0	206	0	206	664
16:45	0	0	6	6	0	206	2	208	172	0	68	240	0	207	0	207	661
Total	0	0	14	14	0	878	15	893	670	0	241	911	0	769	0	769	2587
17:00	0	0	5	5	0	193	7	200	202	0	58	260	0	180	0	180	645
17:15	0	0	1	1	0	208	4	212	203	0	86	289	0	190	0	190	692
17:30	0	0	1	1	0	193	13	206	170	0	75	245	0	203	0	203	655
17:45	0	0	5	5	0	169	8	177	196	0	68	264	0	195	0	195	641
Total	0	0	12	12	0	763	32	795	771	0	287	1058	0	768	0	768	2633
Grand Total	0	0	195	195	0	3135	59	3194	2150	0	800	2950	0	2475	0	2475	8814
Apprch %	0	0	100		0	98.2	1.8		72.9	0	27.1		0	100	0		
Total %	0	0	2.2	2.2	0	35.6	0.7	36.2	24.4	0	9.1	33.5	0	28.1	0	28.1	

# All Traffic Data

(916) 771-8700

CITY OF MENLO PARK

File Name : 11-7274-001 CAPITOL-DONOHUE

Site Code : 00000000

Start Date : 6/8/2011

Page No : 2

Start Time	CAPITOL AVE. Southbound				DONOHUE ST. Westbound				US-101 NB OFF RAMP Northbound				DONOHUE ST. Eastbound				Int. Total
	Left	Thru	Right	App. Total	Left	Thru	Right	App. Total	Left	Thru	Right	App. Total	Left	Thru	Right	App. Total	
Peak Hour Analysis From 07:00 to 08:45 - Peak 1 of 1																	
Peak Hour for Entire Intersection Begins at 07:30																	
07:30	0	0	22	22	0	<b>232</b>	<b>3</b>	<b>235</b>	87	0	<b>48</b>	<b>135</b>	0	109	0	109	<b>501</b>
07:45	0	0	<b>42</b>	<b>42</b>	0	214	1	215	87	0	27	114	0	119	0	119	490
08:00	0	0	28	28	0	206	1	207	<b>104</b>	0	24	128	0	<b>124</b>	0	<b>124</b>	487
08:15	0	0	21	21	0	185	3	188	87	0	41	128	0	99	0	99	436
Total Volume	0	0	113	113	0	837	8	845	365	0	140	505	0	451	0	451	1914
% App. Total	0	0	100		0	99.1	0.9		72.3	0	27.7		0	100	0		
PHF	.000	.000	.673	.673	.000	.902	.667	.899	.877	.000	.729	.935	.000	.909	.000	.909	.955

# All Traffic Data

(916) 771-8700

CITY OF MENLO PARK

File Name : 11-7274-001 CAPITOL-DONOHUE

Site Code : 00000000

Start Date : 6/8/2011

Page No : 3

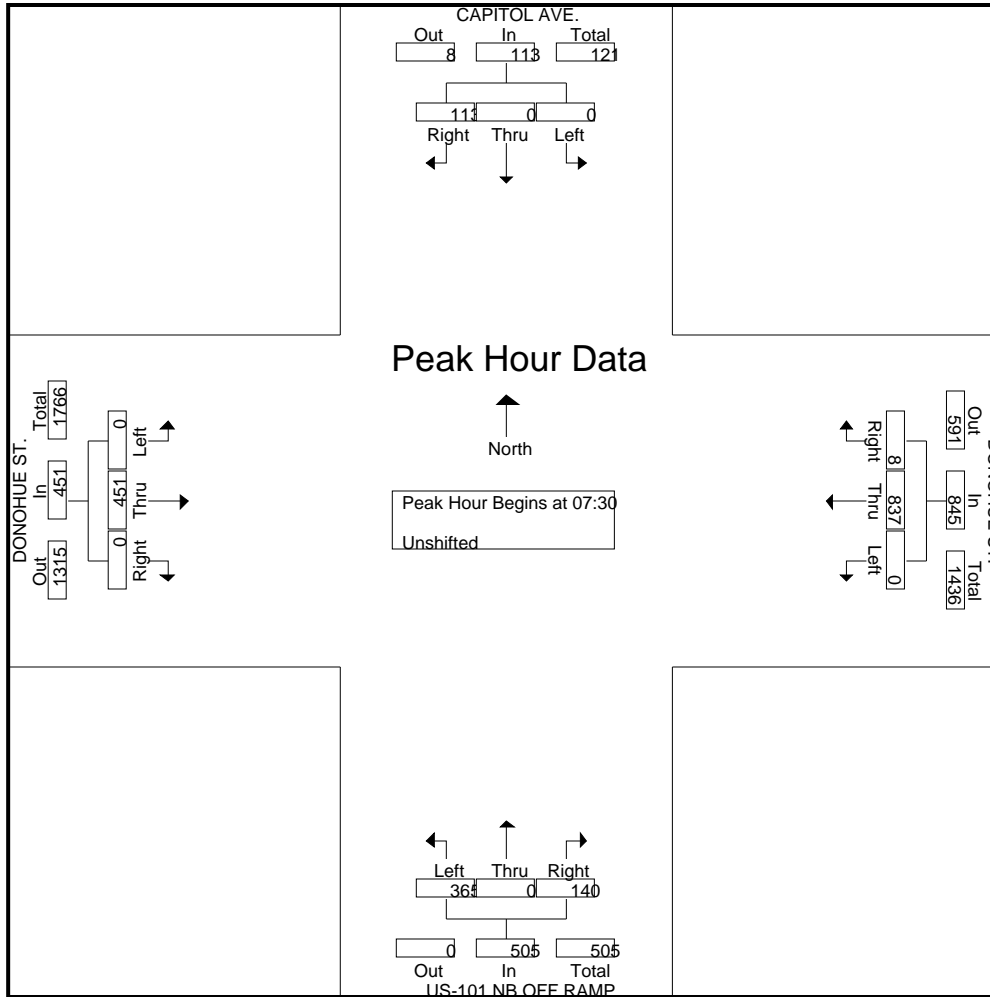

# All Traffic Data

(916) 771-8700

CITY OF MENLO PARK

File Name : 11-7274-001 CAPITOL-DONOHUE

Site Code : 00000000

Start Date : 6/8/2011

Page No : 4

Start Time	CAPITOL AVE. Southbound				DONOHUE ST. Westbound				US-101 NB OFF RAMP Northbound				DONOHUE ST. Eastbound				Int. Total
	Left	Thru	Right	App. Total	Left	Thru	Right	App. Total	Left	Thru	Right	App. Total	Left	Thru	Right	App. Total	
Peak Hour Analysis From 16:00 to 17:45 - Peak 1 of 1																	
Peak Hour for Entire Intersection Begins at 16:30																	
16:30	0	0	4	4	0	195	6	201	188	0	65	253	0	206	0	206	664
16:45	0	0	<b>6</b>	<b>6</b>	0	206	2	208	172	0	68	240	0	<b>207</b>	0	<b>207</b>	661
17:00	0	0	5	5	0	193	7	200	202	0	58	260	0	180	0	180	645
17:15	0	0	1	1	0	<b>208</b>	4	<b>212</b>	<b>203</b>	0	<b>86</b>	<b>289</b>	0	190	0	190	<b>692</b>
Total Volume	0	0	16	16	0	802	19	821	765	0	277	1042	0	783	0	783	2662
% App. Total	0	0	100		0	97.7	2.3		73.4	0	26.6		0	100	0		
PHF	.000	.000	.667	.667	.000	.964	.679	.968	.942	.000	.805	.901	.000	.946	.000	.946	.962

# All Traffic Data

(916) 771-8700

CITY OF MENLO PARK

File Name : 11-7274-001 CAPITOL-DONOHUE

Site Code : 00000000

Start Date : 6/8/2011

Page No : 5

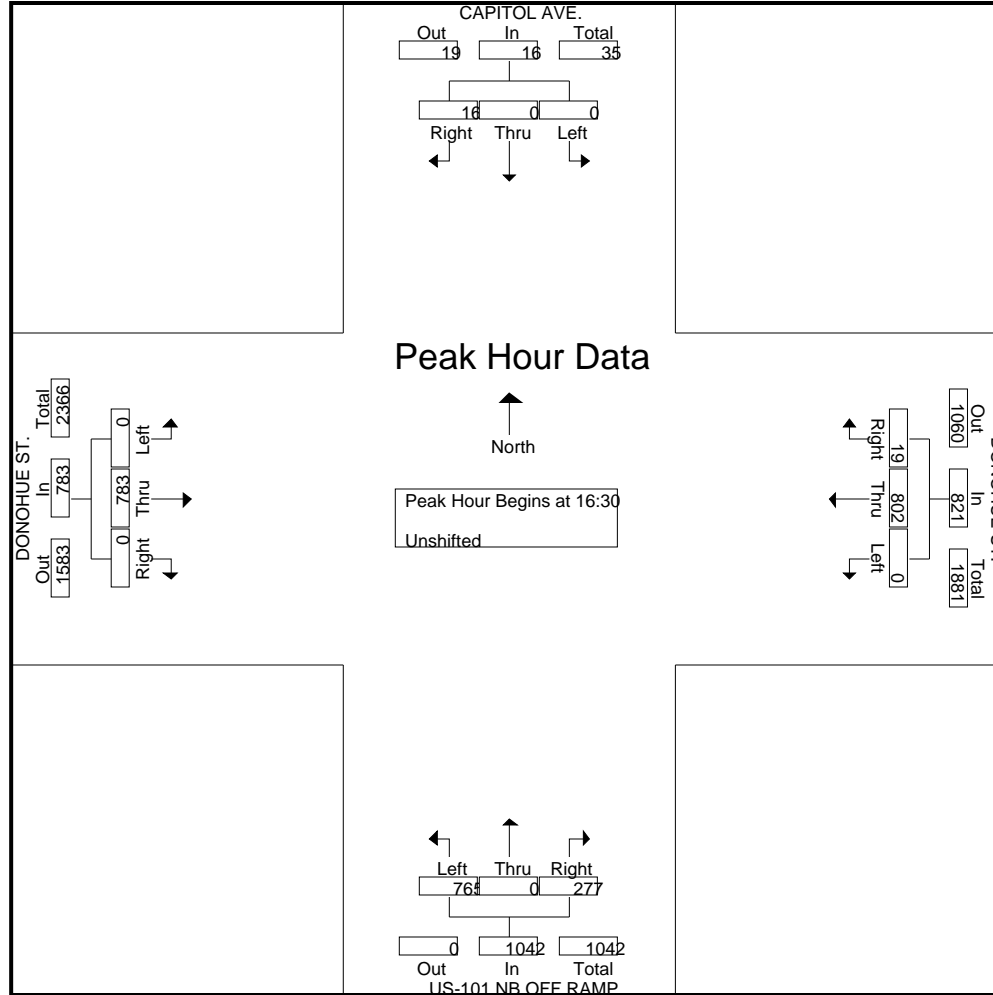

# All Traffic Data

(916) 771-8700

CITY OF MENLO PARK

File Name : 11-7274-002 UNIVERSITY-US101 SB

Site Code : 00000000

Start Date : 6/8/2011

Page No : 1

Groups Printed- Unshifted

Start Time	UNIVERSITY AVE. Southbound				US-101 SB RAMPS Westbound				UNIVERSITY AVE. Northbound				Eastbound				Int. Total
	Left	Thru	Right	App. Total	Left	Thru	Right	App. Total	Left	Thru	Right	App. Total	Left	Thru	Right	App. Total	
07:00	162	234	0	396	78	0	61	139	0	147	58	205	0	0	0	0	740
07:15	224	286	0	510	80	0	60	140	0	171	71	242	0	0	0	0	892
07:30	194	373	0	567	62	0	54	116	0	233	87	320	0	0	0	0	1003
07:45	192	359	0	551	99	0	66	165	0	170	73	243	0	0	0	0	959
Total	772	1252	0	2024	319	0	241	560	0	721	289	1010	0	0	0	0	3594
08:00	182	429	0	611	65	0	58	123	0	255	97	352	0	0	0	0	1086
08:15	199	376	0	575	88	0	43	131	0	187	105	292	0	0	0	0	998
08:30	225	363	0	588	65	0	53	118	0	216	104	320	0	0	0	0	1026
08:45	196	338	0	534	77	0	56	133	0	151	120	271	0	0	0	0	938
Total	802	1506	0	2308	295	0	210	505	0	809	426	1235	0	0	0	0	4048
16:00	54	248	0	302	159	0	101	260	0	238	28	266	0	0	0	0	828
16:15	105	282	0	387	120	0	63	183	0	302	64	366	0	0	0	0	936
16:30	104	232	0	336	71	0	93	164	0	347	105	452	0	0	0	0	952
16:45	128	218	0	346	73	0	125	198	0	343	93	436	0	0	0	0	980
Total	391	980	0	1371	423	0	382	805	0	1230	290	1520	0	0	0	0	3696
17:00	113	215	0	328	89	0	102	191	0	360	95	455	0	0	0	0	974
17:15	139	249	0	388	58	0	99	157	0	361	85	446	0	0	0	0	991
17:30	107	245	0	352	85	0	113	198	0	327	115	442	0	0	0	0	992
17:45	97	245	0	342	64	0	91	155	0	307	93	400	0	0	0	0	897
Total	456	954	0	1410	296	0	405	701	0	1355	388	1743	0	0	0	0	3854
Grand Total	2421	4692	0	7113	1333	0	1238	2571	0	4115	1393	5508	0	0	0	0	15192
Apprch %	34	66	0		51.8	0	48.2		0	74.7	25.3		0	0	0		
Total %	15.9	30.9	0	46.8	8.8	0	8.1	16.9	0	27.1	9.2	36.3	0	0	0	0	

# All Traffic Data

(916) 771-8700

CITY OF MENLO PARK

File Name : 11-7274-002 UNIVERSITY-US101 SB

Site Code : 00000000

Start Date : 6/8/2011

Page No : 2

Start Time	UNIVERSITY AVE. Southbound				US-101 SB RAMPS Westbound				UNIVERSITY AVE. Northbound				Eastbound				Int. Total
	Left	Thru	Right	App. Total	Left	Thru	Right	App. Total	Left	Thru	Right	App. Total	Left	Thru	Right	App. Total	
Peak Hour Analysis From 07:00 to 08:45 - Peak 1 of 1																	
Peak Hour for Entire Intersection Begins at 07:45																	
07:45	192	359	0	551	<b>99</b>	0	<b>66</b>	<b>165</b>	0	170	73	243	0	0	0	0	959
08:00	182	<b>429</b>	0	<b>611</b>	65	0	58	123	0	<b>255</b>	97	<b>352</b>	0	0	0	0	<b>1086</b>
08:15	199	376	0	575	88	0	43	131	0	187	<b>105</b>	292	0	0	0	0	998
08:30	<b>225</b>	363	0	588	65	0	53	118	0	216	104	320	0	0	0	0	1026
Total Volume	798	1527	0	2325	317	0	220	537	0	828	379	1207	0	0	0	0	4069
% App. Total	34.3	65.7	0		59	0	41		0	68.6	31.4		0	0	0		
PHF	.887	.890	.000	.951	.801	.000	.833	.814	.000	.812	.902	.857	.000	.000	.000	.000	.937

# All Traffic Data

(916) 771-8700

CITY OF MENLO PARK

File Name : 11-7274-002 UNIVERSITY-US101 SB

Site Code : 00000000

Start Date : 6/8/2011

Page No : 3

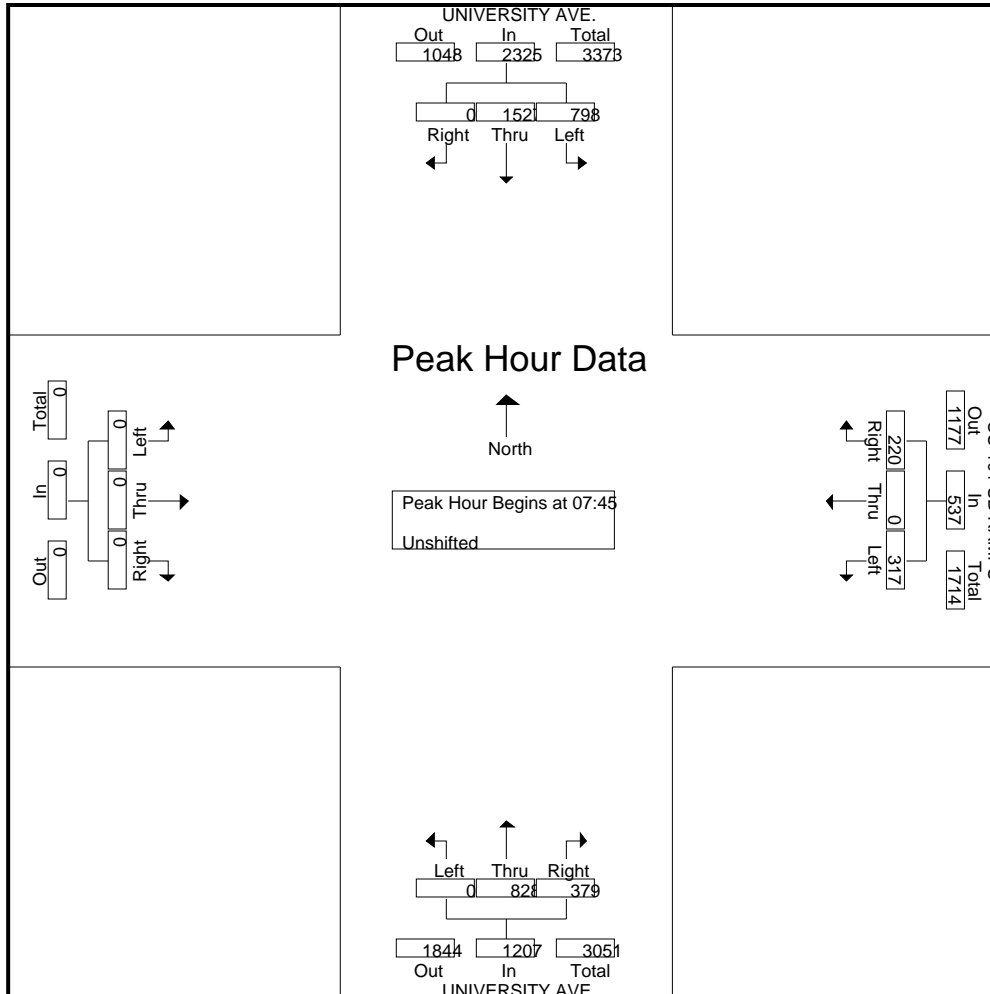



# All Traffic Data

(916) 771-8700

CITY OF MENLO PARK

File Name : 11-7274-002 UNIVERSITY-US101 SB

Site Code : 00000000

Start Date : 6/8/2011

Page No : 4

Start Time	UNIVERSITY AVE. Southbound				US-101 SB RAMPS Westbound				UNIVERSITY AVE. Northbound				Eastbound				Int. Total
	Left	Thru	Right	App. Total	Left	Thru	Right	App. Total	Left	Thru	Right	App. Total	Left	Thru	Right	App. Total	
Peak Hour Analysis From 16:00 to 17:45 - Peak 1 of 1																	
Peak Hour for Entire Intersection Begins at 16:45																	
16:45	128	218	0	346	73	0	<b>125</b>	<b>198</b>	0	343	93	436	0	0	0	0	980
17:00	113	215	0	328	<b>89</b>	0	102	191	0	360	95	<b>455</b>	0	0	0	0	974
17:15	<b>139</b>	<b>249</b>	0	<b>388</b>	58	0	99	157	0	<b>361</b>	85	446	0	0	0	0	991
17:30	107	245	0	352	85	0	113	198	0	327	<b>115</b>	442	0	0	0	0	<b>992</b>
Total Volume	487	927	0	1414	305	0	439	744	0	1391	388	1779	0	0	0	0	3937
% App. Total	34.4	65.6	0		41	0	59		0	78.2	21.8		0	0	0		
PHF	.876	.931	.000	.911	.857	.000	.878	.939	.000	.963	.843	.977	.000	.000	.000	.000	.992

# All Traffic Data

(916) 771-8700

CITY OF MENLO PARK

File Name : 11-7274-002 UNIVERSITY-US101 SB

Site Code : 00000000

Start Date : 6/8/2011

Page No : 5

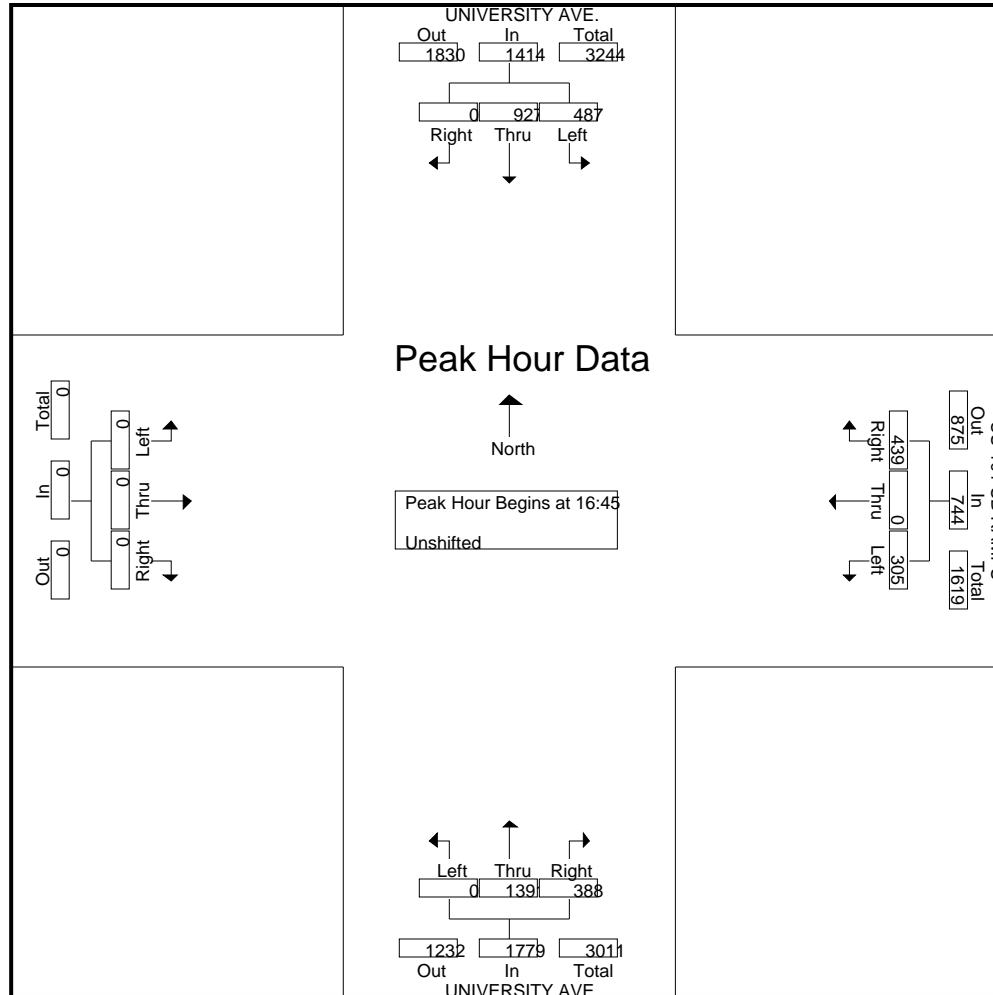

# Traffic Data Service

Campbell, CA  
(408) 377-2988  
tdsbay@cs.com

File Name : 7AM FINAL  
Site Code : 00000007  
Start Date : 11/9/2010  
Page No : 1

### Groups Printed- Vehicles

Start Time	WOODLAND AVE Southbound					UNIVERSITY AVE Westbound					WOODLAND AVE Northbound					UNIVERSITY AVE Eastbound					Int. Total
	Right	Thru	Left	Peds	App. Total	Right	Thru	Left	Peds	App. Total	Right	Thru	Left	Peds	App. Total	Right	Thru	Left	Peds	App. Total	
07:00 AM	17	8	92	0	117	71	276	35	0	382	61	16	6	0	83	1	64	4	0	69	651
07:15 AM	7	10	83	0	100	73	277	54	0	404	68	13	11	0	92	3	89	18	0	110	706
07:30 AM	7	21	98	0	126	72	345	81	0	498	69	20	5	0	94	2	130	8	0	140	858
07:45 AM	12	17	90	0	119	120	383	56	0	559	56	16	3	0	75	6	135	16	0	157	910
<b>Total</b>	<b>43</b>	<b>56</b>	<b>363</b>	<b>0</b>	<b>462</b>	<b>336</b>	<b>1281</b>	<b>226</b>	<b>0</b>	<b>1843</b>	<b>254</b>	<b>65</b>	<b>25</b>	<b>0</b>	<b>344</b>	<b>12</b>	<b>418</b>	<b>46</b>	<b>0</b>	<b>476</b>	<b>3125</b>
08:00 AM	17	67	137	0	221	115	423	48	0	586	56	10	4	0	70	3	126	18	0	147	1024
08:15 AM	5	10	85	0	100	113	355	53	0	521	69	32	2	0	103	2	147	9	0	158	882
08:30 AM	6	16	106	0	128	112	256	74	0	442	45	8	4	0	57	8	139	18	0	165	792
08:45 AM	6	11	63	0	80	68	284	71	0	423	31	17	2	0	50	1	138	33	0	172	725
<b>Total</b>	<b>34</b>	<b>104</b>	<b>391</b>	<b>0</b>	<b>529</b>	<b>408</b>	<b>1318</b>	<b>246</b>	<b>0</b>	<b>1972</b>	<b>201</b>	<b>67</b>	<b>12</b>	<b>0</b>	<b>280</b>	<b>14</b>	<b>550</b>	<b>78</b>	<b>0</b>	<b>642</b>	<b>3423</b>
Grand Total	77	160	754	0	991	744	2599	472	0	3815	455	132	37	0	624	26	968	124	0	1118	6548
Apprch %	7.8	16.1	76.1	0	15.1	19.5	68.1	12.4	0	58.3	72.9	21.2	5.9	0	9.5	2.3	86.6	11.1	0	17.1	
Total %	1.2	2.4	11.5	0	15.1	11.4	39.7	7.2	0	58.3	6.9	2	0.6	0	9.5	0.4	14.8	1.9	0	17.1	

Start Time	WOODLAND AVE Southbound					UNIVERSITY AVE Westbound					WOODLAND AVE Northbound					UNIVERSITY AVE Eastbound					Int. Total
	Right	Thru	Left	Peds	App. Total	Right	Thru	Left	Peds	App. Total	Right	Thru	Left	Peds	App. Total	Right	Thru	Left	Peds	App. Total	
Peak Hour Analysis From 07:00 AM to 08:45 AM - Peak 1 of 1																					
Peak Hour for Entire Intersection Begins at 07:30 AM																					
07:30 AM	7	21	98	0	126	72	345	81	0	498	69	20	5	0	94	2	130	8	0	140	858
07:45 AM	12	17	90	0	119	120	383	56	0	559	56	16	3	0	75	6	135	16	0	157	910
08:00 AM	17	67	137	0	221	115	423	48	0	586	56	10	4	0	70	3	126	18	0	147	1024
08:15 AM	5	10	85	0	100	113	355	53	0	521	69	32	2	0	103	2	147	9	0	158	882
Total Volume	41	115	410	0	566	420	1506	238	0	2164	250	78	14	0	342	13	538	51	0	602	3674
% App. Total	.603	.429	.748	.000	.640	.875	.890	.735	.000	.923	.906	.609	.700	.000	.830	.542	.915	.708	.000	.953	.897
PHF	.603	.429	.748	.000	.640	.875	.890	.735	.000	.923	.906	.609	.700	.000	.830	.542	.915	.708	.000	.953	.897

# Traffic Data Service

Campbell, CA  
 (408) 377-2988  
 tdsbay@cs.com

File Name : 7AM FINAL  
 Site Code : 00000007  
 Start Date : 11/9/2010  
 Page No : 2

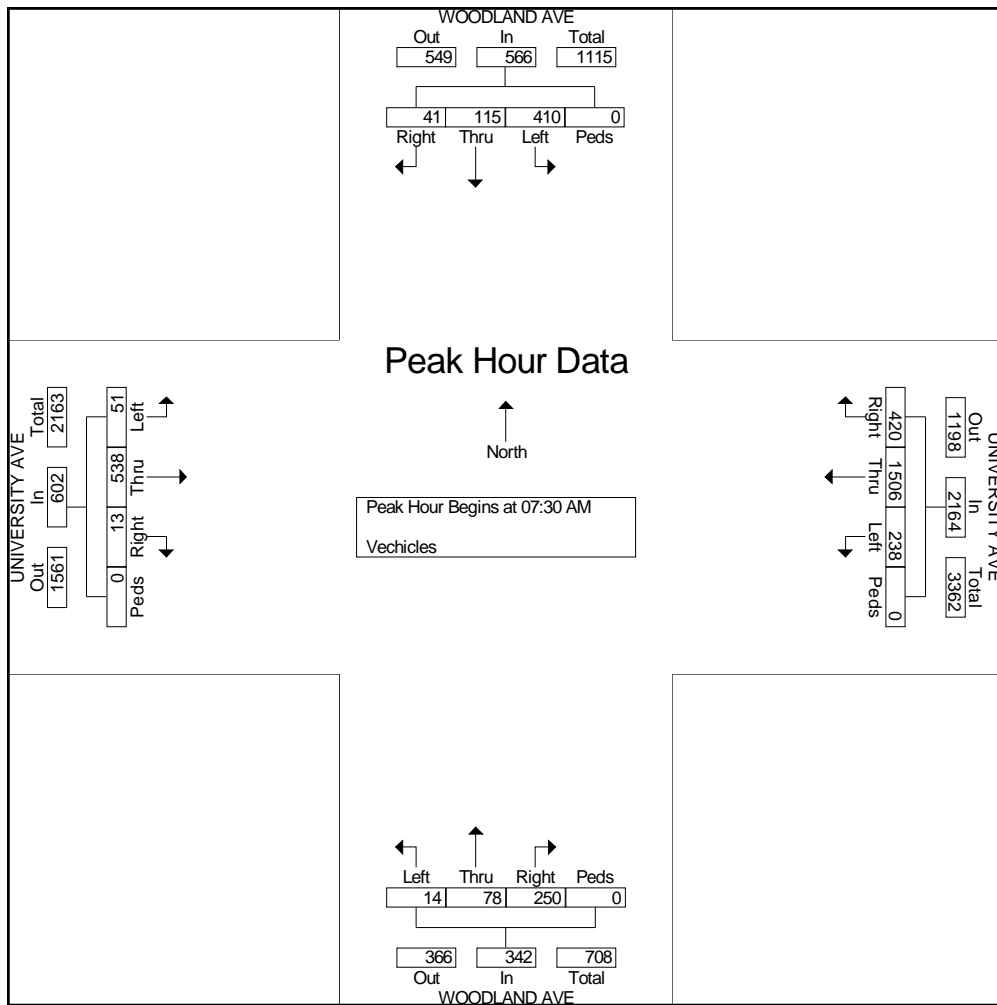

# Traffic Data Service

Campbell, CA  
(408) 377-2988  
tdsbay@cs.com

File Name : 7PM FINAL  
Site Code : 00000007  
Start Date : 11/9/2010  
Page No : 1

### Groups Printed- Vehicles

Start Time	WOODLAND AVE Southbound					UNIVERSITY AVE Westbound					WOODLAND AVE Northbound					UNIVERSITY AVE Eastbound					Int. Total
	Right	Thru	Left	Peds	App. Total	Right	Thru	Left	Peds	App. Total	Right	Thru	Left	Peds	App. Total	Right	Thru	Left	Peds	App. Total	
04:00 PM	9	15	128	0	152	82	187	76	0	345	73	24	6	0	103	5	209	5	0	219	819
04:15 PM	6	14	127	0	147	71	206	53	0	330	84	21	6	0	111	5	205	7	0	217	805
04:30 PM	7	31	157	0	195	92	245	59	0	396	53	25	5	0	83	4	190	10	0	204	878
04:45 PM	6	28	138	0	172	74	223	76	0	373	68	26	2	0	96	2	214	9	0	225	866
<b>Total</b>	<b>28</b>	<b>88</b>	<b>550</b>	<b>0</b>	<b>666</b>	<b>319</b>	<b>861</b>	<b>264</b>	<b>0</b>	<b>1444</b>	<b>278</b>	<b>96</b>	<b>19</b>	<b>0</b>	<b>393</b>	<b>16</b>	<b>818</b>	<b>31</b>	<b>0</b>	<b>865</b>	<b>3368</b>
05:00 PM	12	26	154	0	192	93	164	64	0	321	64	18	3	0	85	2	169	1	0	172	770
05:15 PM	9	34	163	0	206	68	168	75	0	311	89	18	6	0	113	1	236	8	0	245	875
05:30 PM	20	18	142	0	180	69	215	85	0	369	75	21	3	0	99	6	153	11	0	170	818
05:45 PM	14	15	124	0	153	53	203	65	0	321	80	22	2	0	104	4	215	15	0	234	812
<b>Total</b>	<b>55</b>	<b>93</b>	<b>583</b>	<b>0</b>	<b>731</b>	<b>283</b>	<b>750</b>	<b>289</b>	<b>0</b>	<b>1322</b>	<b>308</b>	<b>79</b>	<b>14</b>	<b>0</b>	<b>401</b>	<b>13</b>	<b>773</b>	<b>35</b>	<b>0</b>	<b>821</b>	<b>3275</b>
<b>Grand Total</b>	<b>83</b>	<b>181</b>	<b>1133</b>	<b>0</b>	<b>1397</b>	<b>602</b>	<b>1611</b>	<b>553</b>	<b>0</b>	<b>2766</b>	<b>586</b>	<b>175</b>	<b>33</b>	<b>0</b>	<b>794</b>	<b>29</b>	<b>1591</b>	<b>66</b>	<b>0</b>	<b>1686</b>	<b>6643</b>
<b>Apprch %</b>	<b>5.9</b>	<b>13</b>	<b>81.1</b>	<b>0</b>		<b>21.8</b>	<b>58.2</b>	<b>20</b>	<b>0</b>		<b>73.8</b>	<b>22</b>	<b>4.2</b>	<b>0</b>		<b>1.7</b>	<b>94.4</b>	<b>3.9</b>	<b>0</b>		
<b>Total %</b>	<b>1.2</b>	<b>2.7</b>	<b>17.1</b>	<b>0</b>	<b>21</b>	<b>9.1</b>	<b>24.3</b>	<b>8.3</b>	<b>0</b>	<b>41.6</b>	<b>8.8</b>	<b>2.6</b>	<b>0.5</b>	<b>0</b>	<b>12</b>	<b>0.4</b>	<b>24</b>	<b>1</b>	<b>0</b>	<b>25.4</b>	

Start Time	WOODLAND AVE Southbound					UNIVERSITY AVE Westbound					WOODLAND AVE Northbound					UNIVERSITY AVE Eastbound					Int. Total
	Right	Thru	Left	Peds	App. Total	Right	Thru	Left	Peds	App. Total	Right	Thru	Left	Peds	App. Total	Right	Thru	Left	Peds	App. Total	
Peak Hour Analysis From 04:00 PM to 05:45 PM - Peak 1 of 1																					
Peak Hour for Entire Intersection Begins at 04:30 PM																					
04:30 PM	7	31	157	0	195	92	245	59	0	396	53	25	5	0	83	4	190	10	0	204	878
04:45 PM	6	28	138	0	172	74	223	76	0	373	68	26	2	0	96	2	214	9	0	225	866
05:00 PM	12	26	154	0	192	93	164	64	0	321	64	18	3	0	85	2	169	1	0	172	770
05:15 PM	9	34	163	0	206	68	168	75	0	311	89	18	6	0	113	1	236	8	0	245	875
<b>Total Volume</b>	<b>34</b>	<b>119</b>	<b>612</b>	<b>0</b>	<b>765</b>	<b>327</b>	<b>800</b>	<b>274</b>	<b>0</b>	<b>1401</b>	<b>274</b>	<b>87</b>	<b>16</b>	<b>0</b>	<b>377</b>	<b>9</b>	<b>809</b>	<b>28</b>	<b>0</b>	<b>846</b>	<b>3389</b>
<b>% App. Total</b>	<b>4.4</b>	<b>15.6</b>	<b>80</b>	<b>0</b>		<b>23.3</b>	<b>57.1</b>	<b>19.6</b>	<b>0</b>		<b>72.7</b>	<b>23.1</b>	<b>4.2</b>	<b>0</b>		<b>1.1</b>	<b>95.6</b>	<b>3.3</b>	<b>0</b>		
<b>PHF</b>	<b>.708</b>	<b>.875</b>	<b>.939</b>	<b>.000</b>	<b>.928</b>	<b>.879</b>	<b>.816</b>	<b>.901</b>	<b>.000</b>	<b>.884</b>	<b>.770</b>	<b>.837</b>	<b>.667</b>	<b>.000</b>	<b>.834</b>	<b>.563</b>	<b>.857</b>	<b>.700</b>	<b>.000</b>	<b>.863</b>	<b>.965</b>

# Traffic Data Service

Campbell, CA  
 (408) 377-2988  
 tdsbay@cs.com

File Name : 7PM FINAL  
 Site Code : 00000007  
 Start Date : 11/9/2010  
 Page No : 2

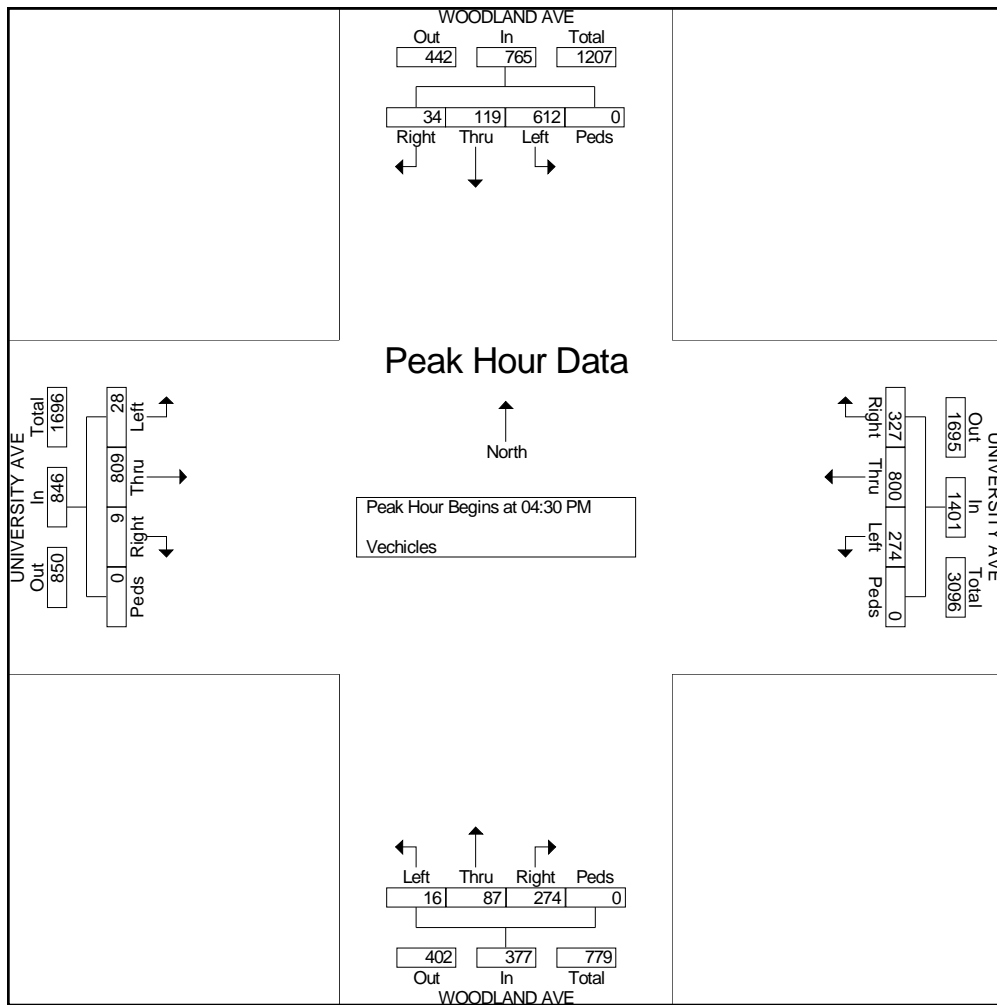

# Traffic Data Service

Campbell, CA  
(408) 377-2988  
tdsbay@cs.com

File Name : 8AM FINAL  
Site Code : 00000008  
Start Date : 11/10/2010  
Page No : 1

### Groups Printed- Vehicles

Start Time	MIDDLEFIELD RD Southbound					UNIVERSITY AVE Westbound					MIDDLEFIELD RD Northbound					UNIVERSITY AVE Eastbound					Int. Total
	Right	Thru	Left	Peds	App. Total	Right	Thru	Left	Peds	App. Total	Right	Thru	Left	Peds	App. Total	Right	Thru	Left	Peds	App. Total	
07:00 AM	13	26	24	0	63	27	121	28	0	176	8	34	6	0	48	5	42	0	0	47	334
07:15 AM	17	50	4	0	71	28	143	13	0	184	13	34	2	0	49	3	42	4	0	49	353
07:30 AM	15	58	14	0	87	34	135	16	0	185	5	43	2	0	50	3	63	6	0	72	394
07:45 AM	14	68	16	0	98	24	161	12	0	197	8	55	2	0	65	4	52	10	0	66	426
<b>Total</b>	<b>59</b>	<b>202</b>	<b>58</b>	<b>0</b>	<b>319</b>	<b>113</b>	<b>560</b>	<b>69</b>	<b>0</b>	<b>742</b>	<b>34</b>	<b>166</b>	<b>12</b>	<b>0</b>	<b>212</b>	<b>15</b>	<b>199</b>	<b>20</b>	<b>0</b>	<b>234</b>	<b>1507</b>
08:00 AM	11	85	27	0	123	22	167	24	0	213	7	57	3	0	67	10	59	2	0	71	474
08:15 AM	23	93	26	0	142	21	148	18	0	187	20	73	11	0	104	3	61	3	0	67	500
08:30 AM	19	102	21	0	142	26	152	14	0	192	12	69	15	0	96	3	62	5	0	70	500
08:45 AM	9	111	18	0	138	26	117	17	0	160	12	65	8	0	85	8	46	5	0	59	442
<b>Total</b>	<b>62</b>	<b>391</b>	<b>92</b>	<b>0</b>	<b>545</b>	<b>95</b>	<b>584</b>	<b>73</b>	<b>0</b>	<b>752</b>	<b>51</b>	<b>264</b>	<b>37</b>	<b>0</b>	<b>352</b>	<b>24</b>	<b>228</b>	<b>15</b>	<b>0</b>	<b>267</b>	<b>1916</b>
<b>Grand Total</b>	<b>121</b>	<b>593</b>	<b>150</b>	<b>0</b>	<b>864</b>	<b>208</b>	<b>1144</b>	<b>142</b>	<b>0</b>	<b>1494</b>	<b>85</b>	<b>430</b>	<b>49</b>	<b>0</b>	<b>564</b>	<b>39</b>	<b>427</b>	<b>35</b>	<b>0</b>	<b>501</b>	<b>3423</b>
<b>Apprch %</b>	<b>14</b>	<b>68.6</b>	<b>17.4</b>	<b>0</b>		<b>13.9</b>	<b>76.6</b>	<b>9.5</b>	<b>0</b>		<b>15.1</b>	<b>76.2</b>	<b>8.7</b>	<b>0</b>		<b>7.8</b>	<b>85.2</b>	<b>7</b>	<b>0</b>		
<b>Total %</b>	<b>3.5</b>	<b>17.3</b>	<b>4.4</b>	<b>0</b>	<b>25.2</b>	<b>6.1</b>	<b>33.4</b>	<b>4.1</b>	<b>0</b>	<b>43.6</b>	<b>2.5</b>	<b>12.6</b>	<b>1.4</b>	<b>0</b>	<b>16.5</b>	<b>1.1</b>	<b>12.5</b>	<b>1</b>	<b>0</b>	<b>14.6</b>	

Start Time	MIDDLEFIELD RD Southbound					UNIVERSITY AVE Westbound					MIDDLEFIELD RD Northbound					UNIVERSITY AVE Eastbound					Int. Total
	Right	Thru	Left	Peds	App. Total	Right	Thru	Left	Peds	App. Total	Right	Thru	Left	Peds	App. Total	Right	Thru	Left	Peds	App. Total	
Peak Hour Analysis From 07:00 AM to 08:45 AM - Peak 1 of 1																					
Peak Hour for Entire Intersection Begins at 08:00 AM																					
08:00 AM	11	85	27	0	123	22	167	24	0	213	7	57	3	0	67	10	59	2	0	71	474
08:15 AM	23	93	26	0	142	21	148	18	0	187	20	73	11	0	104	3	61	3	0	67	500
08:30 AM	19	102	21	0	142	26	152	14	0	192	12	69	15	0	96	3	62	5	0	70	500
08:45 AM	9	111	18	0	138	26	117	17	0	160	12	65	8	0	85	8	46	5	0	59	442
<b>Total Volume</b>	<b>62</b>	<b>391</b>	<b>92</b>	<b>0</b>	<b>545</b>	<b>95</b>	<b>584</b>	<b>73</b>	<b>0</b>	<b>752</b>	<b>51</b>	<b>264</b>	<b>37</b>	<b>0</b>	<b>352</b>	<b>24</b>	<b>228</b>	<b>15</b>	<b>0</b>	<b>267</b>	<b>1916</b>
<b>% App. Total</b>	<b>11.4</b>	<b>71.7</b>	<b>16.9</b>	<b>0</b>		<b>12.6</b>	<b>77.7</b>	<b>9.7</b>	<b>0</b>		<b>14.5</b>	<b>75</b>	<b>10.5</b>	<b>0</b>		<b>9</b>	<b>85.4</b>	<b>5.6</b>	<b>0</b>		
<b>PHF</b>	<b>.674</b>	<b>.881</b>	<b>.852</b>	<b>.000</b>	<b>.960</b>	<b>.913</b>	<b>.874</b>	<b>.760</b>	<b>.000</b>	<b>.883</b>	<b>.638</b>	<b>.904</b>	<b>.617</b>	<b>.000</b>	<b>.846</b>	<b>.600</b>	<b>.919</b>	<b>.750</b>	<b>.000</b>	<b>.940</b>	<b>.958</b>

# Traffic Data Service

Campbell, CA  
 (408) 377-2988  
 tdsbay@cs.com

File Name : 8AM FINAL  
 Site Code : 00000008  
 Start Date : 11/10/2010  
 Page No : 2

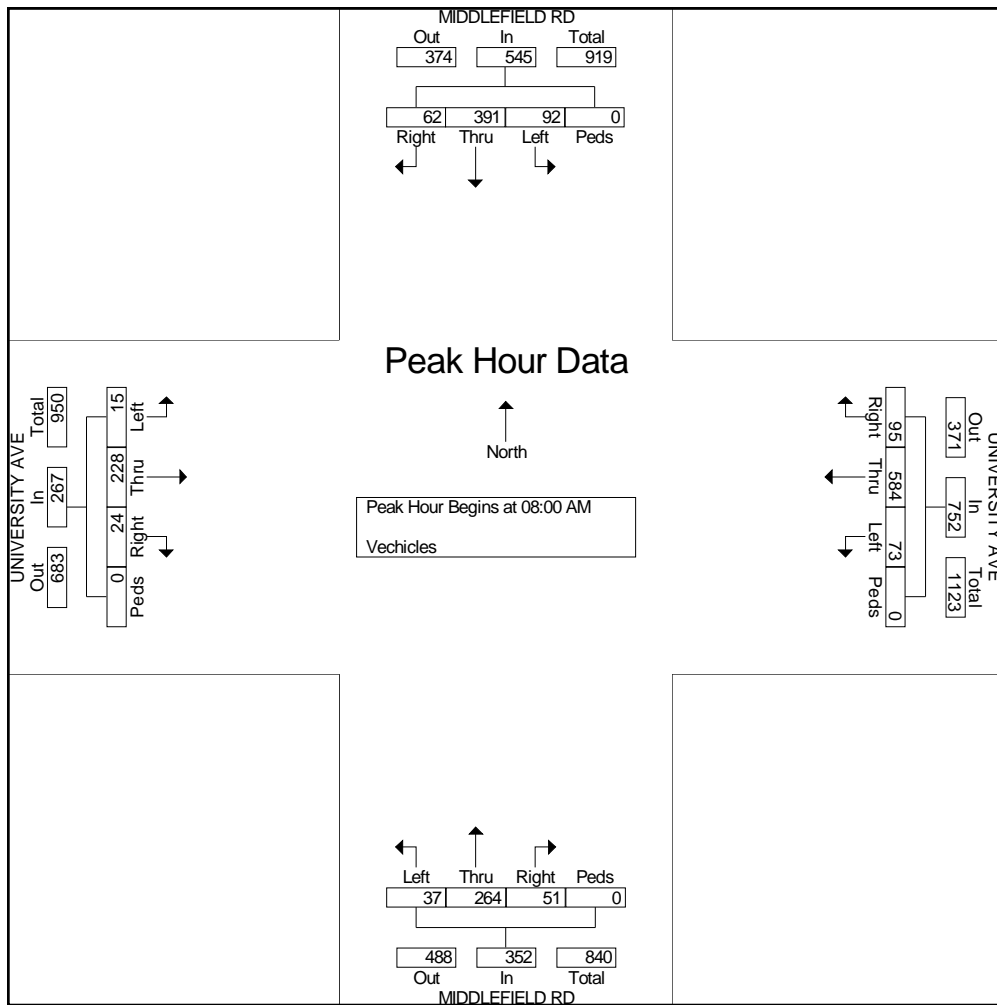



# Traffic Data Service

Campbell, CA  
(408) 377-2988  
tdsbay@cs.com

File Name : 8PM FINAL  
Site Code : 00000008  
Start Date : 11/10/2010  
Page No : 1

### Groups Printed- Vehicles

Start Time	MIDDLEFIELD RD Southbound					UNIVERSITY AVE Westbound					MIDDLEFIELD RD Northbound					UNIVERSITY AVE Eastbound					Int. Total
	Right	Thru	Left	Peds	App. Total	Right	Thru	Left	Peds	App. Total	Right	Thru	Left	Peds	App. Total	Right	Thru	Left	Peds	App. Total	
04:00 PM	10	73	32	0	115	19	91	18	0	128	33	86	14	0	133	8	92	9	0	109	485
04:15 PM	8	79	20	0	107	21	104	14	0	139	32	92	12	0	136	6	78	11	0	95	477
04:30 PM	14	84	24	0	122	27	98	17	0	142	6	85	3	0	94	7	68	22	0	97	455
04:45 PM	24	89	20	0	133	12	90	16	0	118	18	81	8	0	107	6	83	13	0	102	460
<b>Total</b>	<b>56</b>	<b>325</b>	<b>96</b>	<b>0</b>	<b>477</b>	<b>79</b>	<b>383</b>	<b>65</b>	<b>0</b>	<b>527</b>	<b>89</b>	<b>344</b>	<b>37</b>	<b>0</b>	<b>470</b>	<b>27</b>	<b>321</b>	<b>55</b>	<b>0</b>	<b>403</b>	<b>1877</b>
05:00 PM	19	95	21	0	135	25	120	9	0	154	25	112	6	0	143	8	86	22	0	116	548
05:15 PM	19	101	17	0	137	19	99	24	0	142	25	97	9	0	131	3	91	10	0	104	514
05:30 PM	25	96	22	0	143	19	112	17	0	148	19	94	7	0	120	7	80	9	0	96	507
05:45 PM	13	92	22	0	127	25	111	21	0	157	17	74	8	0	99	5	71	18	0	94	477
<b>Total</b>	<b>76</b>	<b>384</b>	<b>82</b>	<b>0</b>	<b>542</b>	<b>88</b>	<b>442</b>	<b>71</b>	<b>0</b>	<b>601</b>	<b>86</b>	<b>377</b>	<b>30</b>	<b>0</b>	<b>493</b>	<b>23</b>	<b>328</b>	<b>59</b>	<b>0</b>	<b>410</b>	<b>2046</b>
<b>Grand Total</b>	<b>132</b>	<b>709</b>	<b>178</b>	<b>0</b>	<b>1019</b>	<b>167</b>	<b>825</b>	<b>136</b>	<b>0</b>	<b>1128</b>	<b>175</b>	<b>721</b>	<b>67</b>	<b>0</b>	<b>963</b>	<b>50</b>	<b>649</b>	<b>114</b>	<b>0</b>	<b>813</b>	<b>3923</b>
Apprch %	13	69.6	17.5	0		14.8	73.1	12.1	0		18.2	74.9	7	0		6.2	79.8	14	0		
Total %	3.4	18.1	4.5	0	26	4.3	21	3.5	0	28.8	4.5	18.4	1.7	0	24.5	1.3	16.5	2.9	0	20.7	

Start Time	MIDDLEFIELD RD Southbound					UNIVERSITY AVE Westbound					MIDDLEFIELD RD Northbound					UNIVERSITY AVE Eastbound					Int. Total
	Right	Thru	Left	Peds	App. Total	Right	Thru	Left	Peds	App. Total	Right	Thru	Left	Peds	App. Total	Right	Thru	Left	Peds	App. Total	
Peak Hour Analysis From 04:00 PM to 05:45 PM - Peak 1 of 1																					
Peak Hour for Entire Intersection Begins at 05:00 PM																					
05:00 PM	19	95	21	0	135	25	120	9	0	154	25	112	6	0	143	8	86	22	0	116	548
05:15 PM	19	101	17	0	137	19	99	24	0	142	25	97	9	0	131	3	91	10	0	104	514
05:30 PM	25	96	22	0	143	19	112	17	0	148	19	94	7	0	120	7	80	9	0	96	507
05:45 PM	13	92	22	0	127	25	111	21	0	157	17	74	8	0	99	5	71	18	0	94	477
<b>Total Volume</b>	<b>76</b>	<b>384</b>	<b>82</b>	<b>0</b>	<b>542</b>	<b>88</b>	<b>442</b>	<b>71</b>	<b>0</b>	<b>601</b>	<b>86</b>	<b>377</b>	<b>30</b>	<b>0</b>	<b>493</b>	<b>23</b>	<b>328</b>	<b>59</b>	<b>0</b>	<b>410</b>	<b>2046</b>
% App. Total	14	70.8	15.1	0		14.6	73.5	11.8	0		17.4	76.5	6.1	0		5.6	80	14.4	0		
PHF	.760	.950	.932	.000	.948	.880	.921	.740	.000	.957	.860	.842	.833	.000	.862	.719	.901	.670	.000	.884	.933

# Traffic Data Service

Campbell, CA  
 (408) 377-2988  
 tdsbay@cs.com

File Name : 8PM FINAL  
 Site Code : 00000008  
 Start Date : 11/10/2010  
 Page No : 2

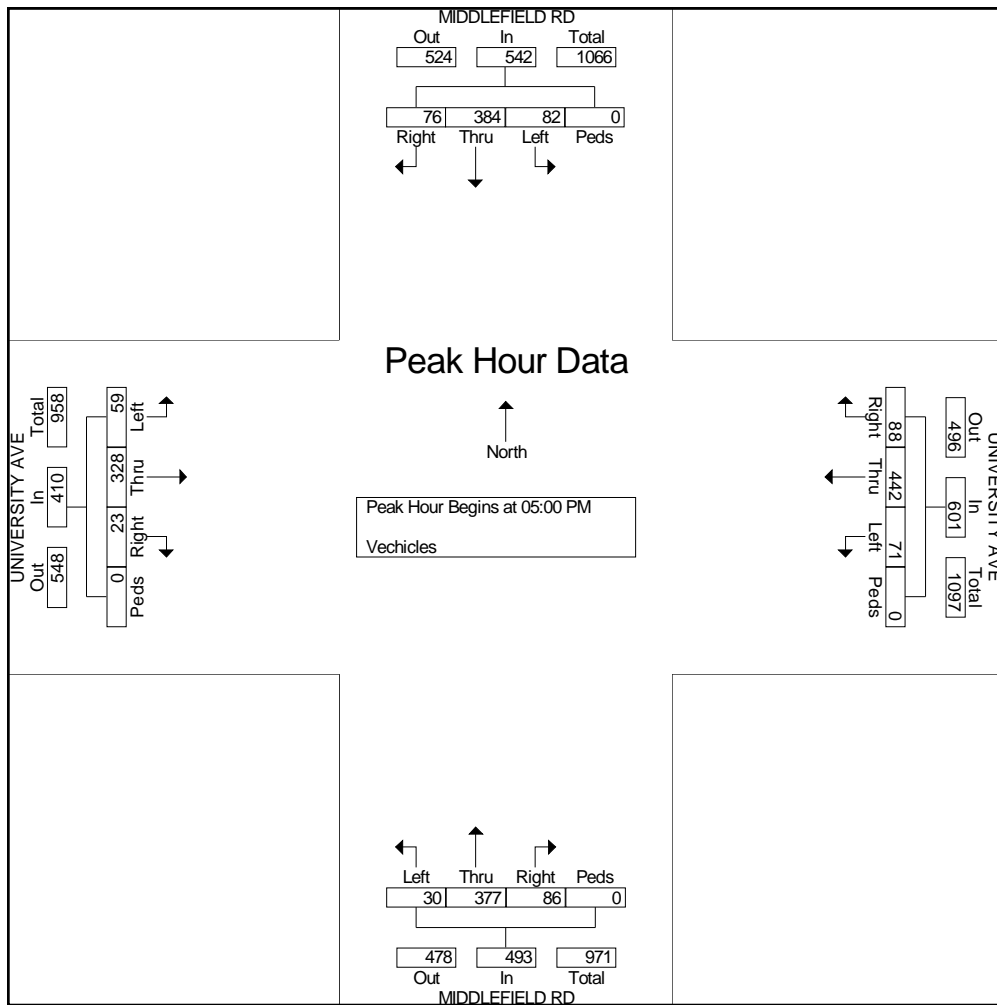

# Traffic Data Service

Campbell, CA  
(408) 377-2988  
tdsbay@cs.com

File Name : 24AM FINAL  
Site Code : 00000024  
Start Date : 11/16/2010  
Page No : 1

## Groups Printed- Vehicles

Start Time	BAYFRONT EXPY Southbound					Westbound					BAYFRONT EXPY Northbound					CHRYSLER DR Eastbound					Int. Total
	Right	Thru	Left	Peds	App. Total	Right	Thru	Left	Peds	App. Total	Right	Thru	Left	Peds	App. Total	Right	Thru	Left	Peds	App. Total	
07:00 AM	7	158	0	0	165	0	0	0	0	0	0	462	8	0	470	3	0	16	0	19	654
07:15 AM	2	183	0	0	185	0	0	0	0	0	0	543	12	0	555	1	0	15	0	16	756
07:30 AM	8	216	0	0	224	0	0	0	0	0	0	612	12	0	624	2	0	33	0	35	883
07:45 AM	6	254	0	0	260	0	0	0	0	0	0	670	10	0	680	0	0	37	0	37	977
<b>Total</b>	<b>23</b>	<b>811</b>	<b>0</b>	<b>0</b>	<b>834</b>	<b>0</b>	<b>0</b>	<b>0</b>	<b>0</b>	<b>0</b>	<b>0</b>	<b>2287</b>	<b>42</b>	<b>0</b>	<b>2329</b>	<b>6</b>	<b>0</b>	<b>101</b>	<b>0</b>	<b>107</b>	<b>3270</b>
08:00 AM	6	292	0	0	298	0	0	0	0	0	0	529	13	0	542	2	0	15	0	17	857
08:15 AM	11	272	0	0	283	0	0	0	0	0	0	551	10	0	561	2	0	18	0	20	864
08:30 AM	9	247	0	0	256	0	0	0	0	0	0	484	10	0	494	2	0	18	0	20	770
08:45 AM	3	251	0	0	254	0	0	0	0	0	0	510	9	0	519	3	0	9	0	12	785
<b>Total</b>	<b>29</b>	<b>1062</b>	<b>0</b>	<b>0</b>	<b>1091</b>	<b>0</b>	<b>0</b>	<b>0</b>	<b>0</b>	<b>0</b>	<b>0</b>	<b>2074</b>	<b>42</b>	<b>0</b>	<b>2116</b>	<b>9</b>	<b>0</b>	<b>60</b>	<b>0</b>	<b>69</b>	<b>3276</b>
<b>Grand Total</b>	<b>52</b>	<b>1873</b>	<b>0</b>	<b>0</b>	<b>1925</b>	<b>0</b>	<b>0</b>	<b>0</b>	<b>0</b>	<b>0</b>	<b>0</b>	<b>4361</b>	<b>84</b>	<b>0</b>	<b>4445</b>	<b>15</b>	<b>0</b>	<b>161</b>	<b>0</b>	<b>176</b>	<b>6546</b>
Apprch %	2.7	97.3	0	0		0	0	0	0		0	98.1	1.9	0		8.5	0	91.5	0		
Total %	0.8	28.6	0	0	29.4	0	0	0	0	0	0	66.6	1.3	0	67.9	0.2	0	2.5	0	2.7	

Start Time	BAYFRONT EXPY Southbound					Westbound					BAYFRONT EXPY Northbound					CHRYSLER DR Eastbound					Int. Total
	Right	Thru	Left	Peds	App. Total	Right	Thru	Left	Peds	App. Total	Right	Thru	Left	Peds	App. Total	Right	Thru	Left	Peds	App. Total	
Peak Hour Analysis From 07:00 AM to 08:45 AM - Peak 1 of 1																					
Peak Hour for Entire Intersection Begins at 07:30 AM																					
07:30 AM	8	216	0	0	224	0	0	0	0	0	0	612	12	0	624	2	0	33	0	35	883
07:45 AM	6	254	0	0	260	0	0	0	0	0	0	670	10	0	680	0	0	37	0	37	977
08:00 AM	6	292	0	0	298	0	0	0	0	0	0	529	13	0	542	2	0	15	0	17	857
08:15 AM	11	272	0	0	283	0	0	0	0	0	0	551	10	0	561	2	0	18	0	20	864
Total Volume	31	1034	0	0	1065	0	0	0	0	0	0	2362	45	0	2407	6	0	103	0	109	3581
% App. Total																					
PHF	.705	.885	.000	.000	.893	.000	.000	.000	.000	.000	.000	.881	.865	.000	.885	.750	.000	.696	.000	.736	.916

# Traffic Data Service

Campbell, CA  
 (408) 377-2988  
 tdsbay@cs.com

File Name : 24AM FINAL  
 Site Code : 00000024  
 Start Date : 11/16/2010  
 Page No : 2

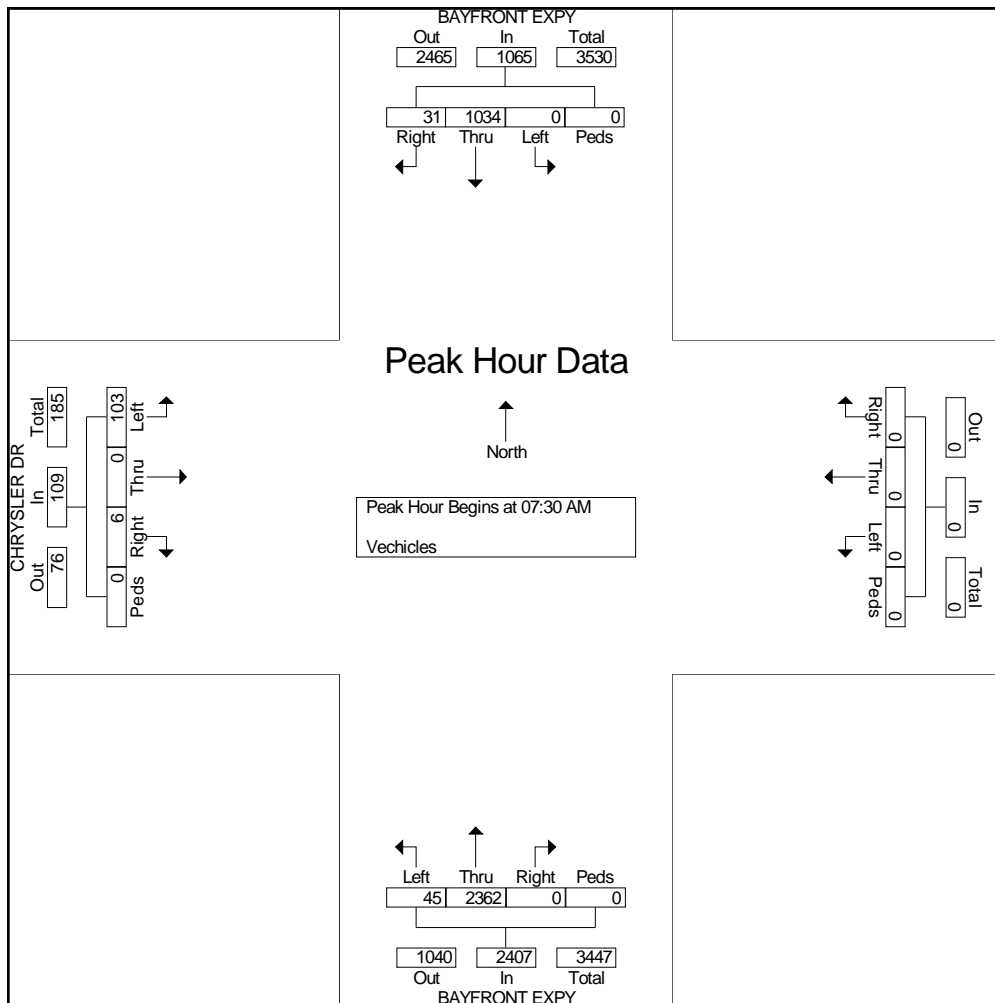

# Traffic Data Service

Campbell, CA  
(408) 377-2988  
tdsbay@cs.com

File Name : 24PM FINAL  
Site Code : 00000024  
Start Date : 11/16/2010  
Page No : 1

## Groups Printed- Vehicles

Start Time	BAYFRONT EXPY Southbound					Westbound					BAYFRONT EXPY Northbound					CHRYSLER DR Eastbound					Int. Total
	Right	Thru	Left	Peds	App. Total	Right	Thru	Left	Peds	App. Total	Right	Thru	Left	Peds	App. Total	Right	Thru	Left	Peds	App. Total	
04:00 PM	2	427	0	0	429	0	0	0	0	0	0	185	4	0	189	9	0	78	0	87	705
04:15 PM	3	526	0	0	529	0	0	0	0	0	0	216	0	0	216	8	0	59	0	67	812
04:30 PM	4	489	0	0	493	0	0	0	0	0	0	205	1	0	206	21	0	84	0	105	804
04:45 PM	4	510	0	0	514	0	0	0	0	0	0	201	4	0	205	14	0	67	0	81	800
<b>Total</b>	<b>13</b>	<b>1952</b>	<b>0</b>	<b>0</b>	<b>1965</b>	<b>0</b>	<b>0</b>	<b>0</b>	<b>0</b>	<b>0</b>	<b>0</b>	<b>807</b>	<b>9</b>	<b>0</b>	<b>816</b>	<b>52</b>	<b>0</b>	<b>288</b>	<b>0</b>	<b>340</b>	<b>3121</b>
05:00 PM	5	558	0	0	563	0	0	0	0	0	0	226	2	0	228	20	0	109	0	129	920
05:15 PM	5	591	0	0	596	0	0	0	0	0	0	255	3	0	258	22	0	81	0	103	957
05:30 PM	2	576	0	0	578	0	0	0	0	0	0	250	1	0	251	20	0	77	0	97	926
05:45 PM	3	531	0	0	534	0	0	0	0	0	0	169	3	0	172	2	0	62	0	64	770
<b>Total</b>	<b>15</b>	<b>2256</b>	<b>0</b>	<b>0</b>	<b>2271</b>	<b>0</b>	<b>0</b>	<b>0</b>	<b>0</b>	<b>0</b>	<b>0</b>	<b>900</b>	<b>9</b>	<b>0</b>	<b>909</b>	<b>64</b>	<b>0</b>	<b>329</b>	<b>0</b>	<b>393</b>	<b>3573</b>
Grand Total	28	4208	0	0	4236	0	0	0	0	0	0	1707	18	0	1725	116	0	617	0	733	6694
Apprch %	0.7	99.3	0	0		0	0	0	0		0	99	1	0		15.8	0	84.2	0		
Total %	0.4	62.9	0	0	63.3	0	0	0	0	0	0	25.5	0.3	0	25.8	1.7	0	9.2	0	11	

Start Time	BAYFRONT EXPY Southbound					Westbound					BAYFRONT EXPY Northbound					CHRYSLER DR Eastbound					Int. Total
	Right	Thru	Left	Peds	App. Total	Right	Thru	Left	Peds	App. Total	Right	Thru	Left	Peds	App. Total	Right	Thru	Left	Peds	App. Total	
Peak Hour Analysis From 04:00 PM to 05:45 PM - Peak 1 of 1																					
Peak Hour for Entire Intersection Begins at 04:45 PM																					
04:45 PM	4	510	0	0	514	0	0	0	0	0	0	201	4	0	205	14	0	67	0	81	800
05:00 PM	5	558	0	0	563	0	0	0	0	0	0	226	2	0	228	20	0	109	0	129	920
05:15 PM	5	591	0	0	596	0	0	0	0	0	0	255	3	0	258	22	0	81	0	103	957
05:30 PM	2	576	0	0	578	0	0	0	0	0	0	250	1	0	251	20	0	77	0	97	926
Total Volume	16	2235	0	0	2251	0	0	0	0	0	0	932	10	0	942	76	0	334	0	410	3603
% App. Total																					
PHF	.800	.945	.000	.000	.944	.000	.000	.000	.000	.000	.000	.914	.625	.000	.913	.864	.000	.766	.000	.795	.941

# Traffic Data Service

Campbell, CA  
 (408) 377-2988  
 tdsbay@cs.com

File Name : 24PM FINAL  
 Site Code : 00000024  
 Start Date : 11/16/2010  
 Page No : 2

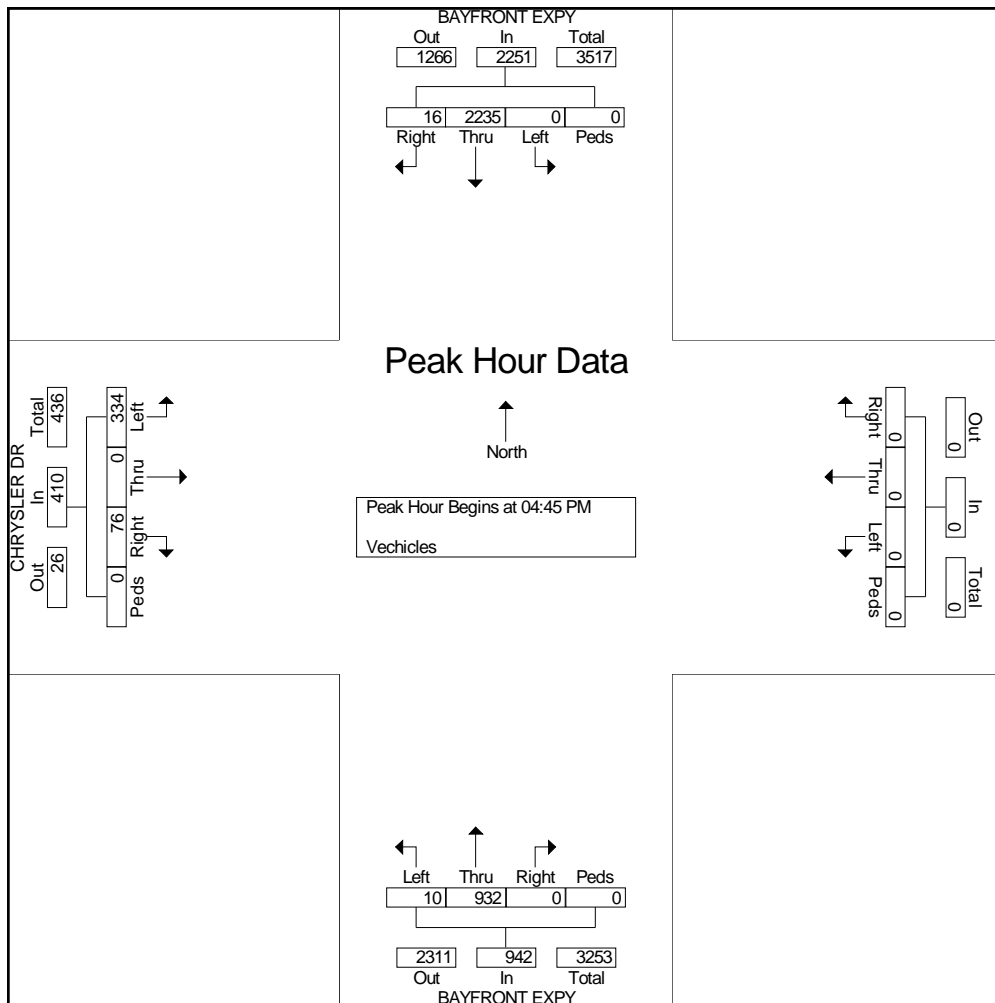

# Traffic Data Service

Campbell, CA  
 (408) 377-2988  
 tdsbay@cs.com

File Name : 23AM FINAL  
 Site Code : 00000023  
 Start Date : 11/16/2010  
 Page No : 1

### Groups Printed- Vehicles

Start Time	BAYFRONT EXPY Southbound					Westbound					BAYFRONT EXPY Northbound					CHILCO ST Eastbound					Int. Total
	Right	Thru	Left	Peds	App. Total	Right	Thru	Left	Peds	App. Total	Right	Thru	Left	Peds	App. Total	Right	Thru	Left	Peds	App. Total	
07:00 AM	23	137	0	0	160	0	0	0	0	0	0	397	25	0	422	10	0	43	0	53	635
07:15 AM	38	153	0	0	191	0	0	0	0	0	0	524	31	0	555	5	0	57	0	62	808
07:30 AM	27	193	0	0	220	0	0	0	0	0	0	539	33	0	572	5	0	59	0	64	856
07:45 AM	63	194	0	0	257	0	0	0	0	0	0	580	37	0	617	12	0	63	0	75	949
<b>Total</b>	<b>151</b>	<b>677</b>	<b>0</b>	<b>0</b>	<b>828</b>	<b>0</b>	<b>0</b>	<b>0</b>	<b>0</b>	<b>0</b>	<b>0</b>	<b>2040</b>	<b>126</b>	<b>0</b>	<b>2166</b>	<b>32</b>	<b>0</b>	<b>222</b>	<b>0</b>	<b>254</b>	<b>3248</b>
08:00 AM	51	236	0	0	287	0	0	0	0	0	0	482	35	0	517	2	0	53	0	55	859
08:15 AM	55	228	0	0	283	0	0	0	0	0	0	469	41	0	510	12	0	43	0	55	848
08:30 AM	38	227	0	0	265	0	0	0	0	0	0	496	39	0	535	4	0	45	0	49	849
08:45 AM	24	242	0	0	266	0	0	0	0	0	0	509	43	0	552	12	0	26	0	38	856
<b>Total</b>	<b>168</b>	<b>933</b>	<b>0</b>	<b>0</b>	<b>1101</b>	<b>0</b>	<b>0</b>	<b>0</b>	<b>0</b>	<b>0</b>	<b>0</b>	<b>1956</b>	<b>158</b>	<b>0</b>	<b>2114</b>	<b>30</b>	<b>0</b>	<b>167</b>	<b>0</b>	<b>197</b>	<b>3412</b>
Grand Total	319	1610	0	0	1929	0	0	0	0	0	0	3996	284	0	4280	62	0	389	0	451	6660
Apprch %	16.5	83.5	0	0		0	0	0	0	0	0	93.4	6.6	0		13.7	0	86.3	0		
Total %	4.8	24.2	0	0	29	0	0	0	0	0	0	60	4.3	0	64.3	0.9	0	5.8	0	6.8	

Start Time	BAYFRONT EXPY Southbound					Westbound					BAYFRONT EXPY Northbound					CHILCO ST Eastbound					Int. Total
	Right	Thru	Left	Peds	App. Total	Right	Thru	Left	Peds	App. Total	Right	Thru	Left	Peds	App. Total	Right	Thru	Left	Peds	App. Total	
Peak Hour Analysis From 07:00 AM to 08:45 AM - Peak 1 of 1																					
Peak Hour for Entire Intersection Begins at 07:30 AM																					
07:30 AM	27	193	0	0	220	0	0	0	0	0	0	539	33	0	572	5	0	59	0	64	856
07:45 AM	63	194	0	0	257	0	0	0	0	0	0	580	37	0	617	12	0	63	0	75	949
08:00 AM	51	236	0	0	287	0	0	0	0	0	0	482	35	0	517	2	0	53	0	55	859
08:15 AM	55	228	0	0	283	0	0	0	0	0	0	469	41	0	510	12	0	43	0	55	848
Total Volume	196	851	0	0	1047	0	0	0	0	0	0	2070	146	0	2216	31	0	218	0	249	3512
% App. Total																					
PHF	.778	.901	.000	.000	.912	.000	.000	.000	.000	.000	.000	.892	.890	.000	.898	.646	.000	.865	.000	.830	.925

# Traffic Data Service

Campbell, CA  
 (408) 377-2988  
 tdsbay@cs.com

File Name : 23AM FINAL  
 Site Code : 00000023  
 Start Date : 11/16/2010  
 Page No : 2

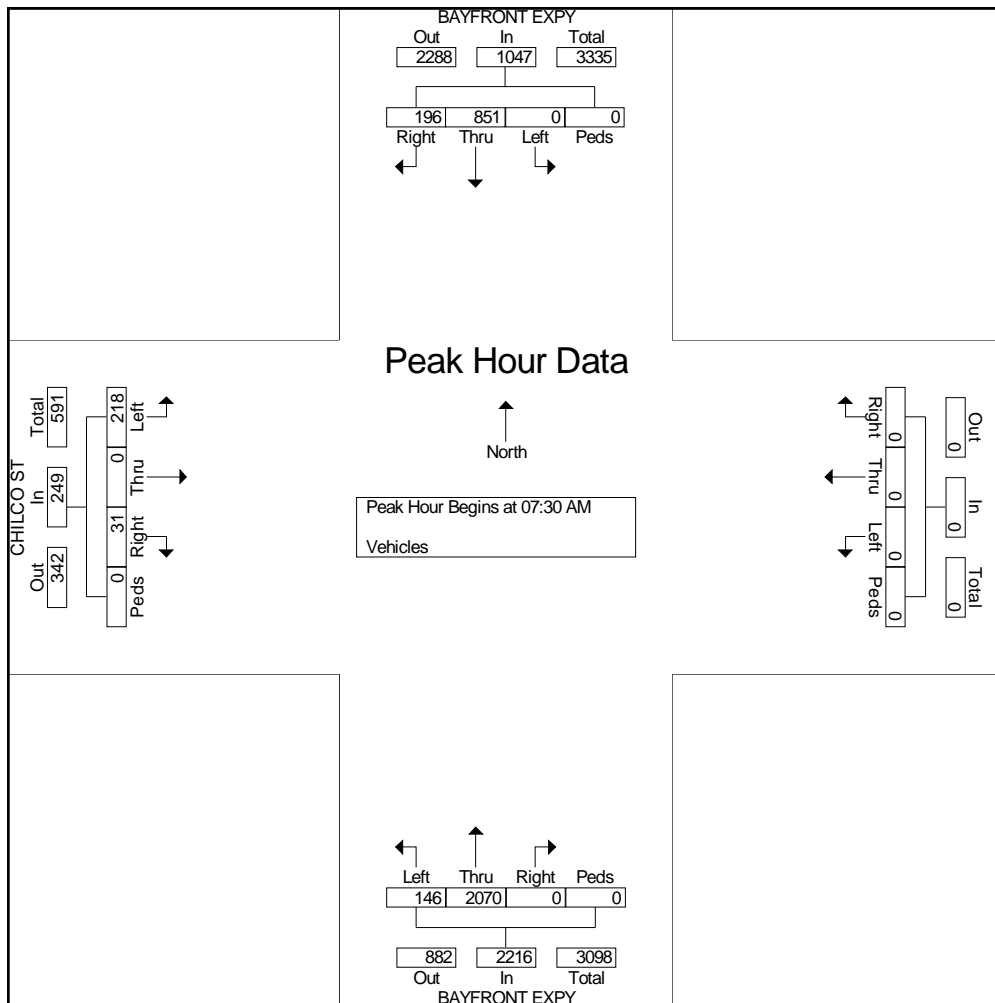



# Traffic Data Service

Campbell, CA  
(408) 377-2988  
tdsbay@cs.com

File Name : 23PM FINAL  
Site Code : 00000023  
Start Date : 11/16/2010  
Page No : 1

### Groups Printed- Vehicles

Start Time	BAYFRONT EXPY Southbound					Westbound					BAYFRONT EXPY Northbound					CHILCO ST Eastbound					Int. Total
	Right	Thru	Left	Peds	App. Total	Right	Thru	Left	Peds	App. Total	Right	Thru	Left	Peds	App. Total	Right	Thru	Left	Peds	App. Total	
04:00 PM	36	395	0	0	431	0	0	0	0	0	0	154	6	0	160	44	0	44	0	88	679
04:15 PM	44	478	0	0	522	0	0	0	0	0	0	179	3	0	182	38	0	36	0	74	778
04:30 PM	36	454	0	0	490	0	0	0	0	0	0	182	10	0	192	47	0	45	0	92	774
04:45 PM	39	481	0	0	520	0	0	0	0	0	0	180	4	0	184	48	0	41	0	89	793
<b>Total</b>	<b>155</b>	<b>1808</b>	<b>0</b>	<b>0</b>	<b>1963</b>	<b>0</b>	<b>0</b>	<b>0</b>	<b>0</b>	<b>0</b>	<b>0</b>	<b>695</b>	<b>23</b>	<b>0</b>	<b>718</b>	<b>177</b>	<b>0</b>	<b>166</b>	<b>0</b>	<b>343</b>	<b>3024</b>
05:00 PM	33	546	0	0	579	0	0	0	0	0	0	175	5	0	180	47	0	54	0	101	860
05:15 PM	43	556	0	0	599	0	0	0	0	0	0	236	4	0	240	37	0	45	0	82	921
05:30 PM	45	543	0	0	588	0	0	0	0	0	0	192	1	0	193	54	0	50	0	104	885
05:45 PM	44	468	0	0	512	0	0	0	0	0	0	155	3	0	158	47	0	36	0	83	753
<b>Total</b>	<b>165</b>	<b>2113</b>	<b>0</b>	<b>0</b>	<b>2278</b>	<b>0</b>	<b>0</b>	<b>0</b>	<b>0</b>	<b>0</b>	<b>0</b>	<b>758</b>	<b>13</b>	<b>0</b>	<b>771</b>	<b>185</b>	<b>0</b>	<b>185</b>	<b>0</b>	<b>370</b>	<b>3419</b>
<b>Grand Total</b>	<b>320</b>	<b>3921</b>	<b>0</b>	<b>0</b>	<b>4241</b>	<b>0</b>	<b>0</b>	<b>0</b>	<b>0</b>	<b>0</b>	<b>0</b>	<b>1453</b>	<b>36</b>	<b>0</b>	<b>1489</b>	<b>362</b>	<b>0</b>	<b>351</b>	<b>0</b>	<b>713</b>	<b>6443</b>
Apprch %	7.5	92.5	0	0		0	0	0	0		0	97.6	2.4	0		50.8	0	49.2	0		
Total %	5	60.9	0	0	65.8	0	0	0	0	0	0	22.6	0.6	0	23.1	5.6	0	5.4	0	11.1	

Start Time	BAYFRONT EXPY Southbound					Westbound					BAYFRONT EXPY Northbound					CHILCO ST Eastbound					Int. Total
	Right	Thru	Left	Peds	App. Total	Right	Thru	Left	Peds	App. Total	Right	Thru	Left	Peds	App. Total	Right	Thru	Left	Peds	App. Total	
Peak Hour Analysis From 04:00 PM to 05:45 PM - Peak 1 of 1																					
Peak Hour for Entire Intersection Begins at 04:45 PM																					
04:45 PM	39	481	0	0	520	0	0	0	0	0	0	180	4	0	184	48	0	41	0	89	793
05:00 PM	33	546	0	0	579	0	0	0	0	0	0	175	5	0	180	47	0	54	0	101	860
05:15 PM	43	556	0	0	599	0	0	0	0	0	0	236	4	0	240	37	0	45	0	82	921
05:30 PM	45	543	0	0	588	0	0	0	0	0	0	192	1	0	193	54	0	50	0	104	885
Total Volume	160	2126	0	0	2286	0	0	0	0	0	0	783	14	0	797	186	0	190	0	376	3459
% App. Total																					
PHF	.889	.956	.000	.000	.954	.000	.000	.000	.000	.000	.000	.829	.700	.000	.830	.861	.000	.880	.000	.904	.939

# Traffic Data Service

Campbell, CA  
 (408) 377-2988  
 tdsbay@cs.com

File Name : 23PM FINAL  
 Site Code : 00000023  
 Start Date : 11/16/2010  
 Page No : 2

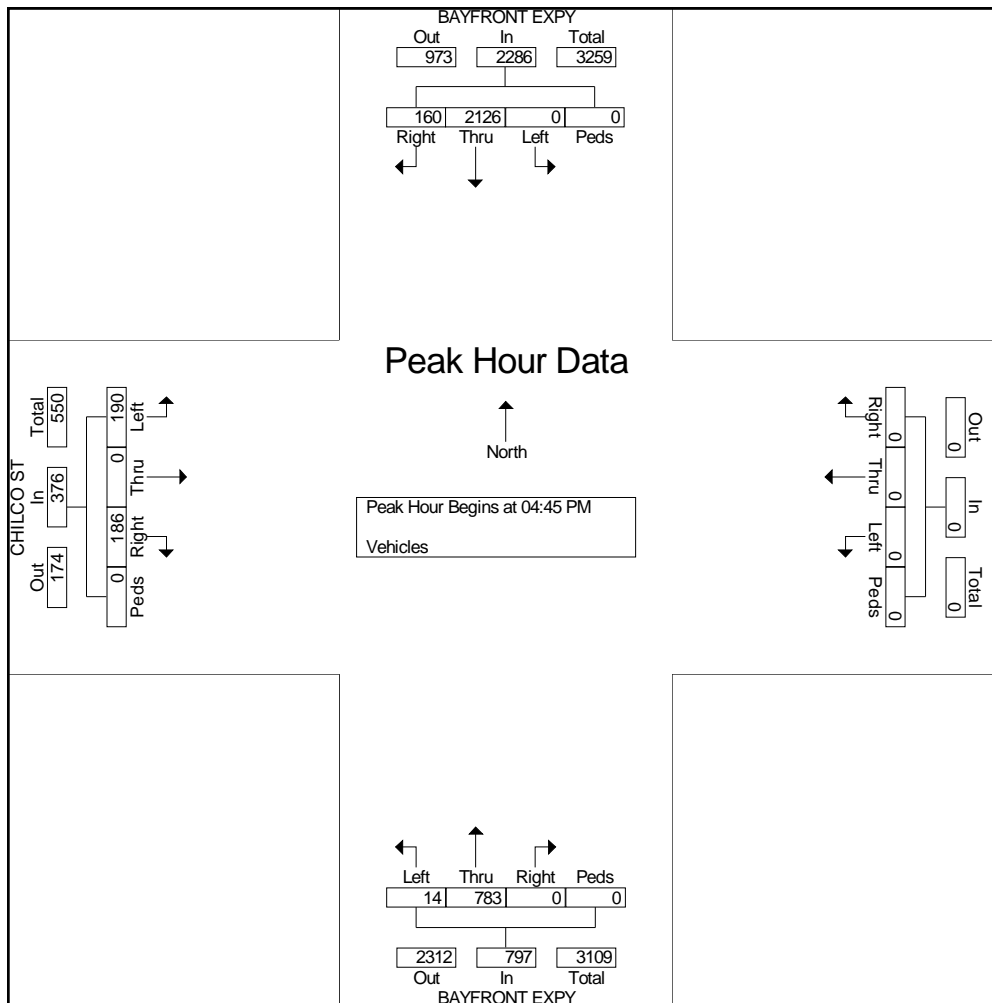

# Traffic Data Service

Campbell, CA  
(408) 377-2988  
tdsbay@cs.com

File Name : 12AM FINAL  
Site Code : 00000012  
Start Date : 11/10/2010  
Page No : 1

### Groups Printed- Vehicles

Start Time	MIDDLEFIELD RD Southbound					Westbound					MIDDLEFIELD RD Northbound					RAVENSWOOD AVE Eastbound					Int. Total
	Right	Thru	Left	Peds	App. Total	Right	Thru	Left	Peds	App. Total	Right	Thru	Left	Peds	App. Total	Right	Thru	Left	Peds	App. Total	
07:00 AM	11	47	0	0	58	0	0	0	0	0	0	47	81	0	128	49	0	12	0	61	247
07:15 AM	21	50	0	0	71	0	0	0	0	0	0	72	102	0	174	55	0	17	0	72	317
07:30 AM	18	65	0	0	83	0	0	0	0	0	0	120	127	0	247	84	0	13	0	97	427
07:45 AM	15	72	0	0	87	0	0	0	0	0	0	117	127	0	244	127	0	21	0	148	479
<b>Total</b>	<b>65</b>	<b>234</b>	<b>0</b>	<b>0</b>	<b>299</b>	<b>0</b>	<b>0</b>	<b>0</b>	<b>0</b>	<b>0</b>	<b>0</b>	<b>356</b>	<b>437</b>	<b>0</b>	<b>793</b>	<b>315</b>	<b>0</b>	<b>63</b>	<b>0</b>	<b>378</b>	<b>1470</b>
08:00 AM	17	120	0	0	137	0	0	0	0	0	0	113	112	0	225	153	0	18	0	171	533
08:15 AM	15	83	0	0	98	0	0	0	0	0	0	70	113	0	183	132	0	26	0	158	439
08:30 AM	22	94	0	0	116	0	0	0	0	0	0	102	106	0	208	109	0	28	0	137	461
08:45 AM	12	101	0	0	113	0	0	0	0	0	0	81	133	0	214	167	0	11	0	178	505
<b>Total</b>	<b>66</b>	<b>398</b>	<b>0</b>	<b>0</b>	<b>464</b>	<b>0</b>	<b>0</b>	<b>0</b>	<b>0</b>	<b>0</b>	<b>0</b>	<b>366</b>	<b>464</b>	<b>0</b>	<b>830</b>	<b>561</b>	<b>0</b>	<b>83</b>	<b>0</b>	<b>644</b>	<b>1938</b>
<b>Grand Total</b>	<b>131</b>	<b>632</b>	<b>0</b>	<b>0</b>	<b>763</b>	<b>0</b>	<b>0</b>	<b>0</b>	<b>0</b>	<b>0</b>	<b>0</b>	<b>722</b>	<b>901</b>	<b>0</b>	<b>1623</b>	<b>876</b>	<b>0</b>	<b>146</b>	<b>0</b>	<b>1022</b>	<b>3408</b>
Apprch %	17.2	82.8	0	0		0	0	0	0		0	44.5	55.5	0		85.7	0	14.3	0		
Total %	3.8	18.5	0	0	22.4	0	0	0	0	0	0	21.2	26.4	0	47.6	25.7	0	4.3	0	30	

Start Time	MIDDLEFIELD RD Southbound					Westbound					MIDDLEFIELD RD Northbound					RAVENSWOOD AVE Eastbound					Int. Total
	Right	Thru	Left	Peds	App. Total	Right	Thru	Left	Peds	App. Total	Right	Thru	Left	Peds	App. Total	Right	Thru	Left	Peds	App. Total	
Peak Hour Analysis From 07:00 AM to 08:45 AM - Peak 1 of 1																					
Peak Hour for Entire Intersection Begins at 08:00 AM																					
08:00 AM	17	120	0	0	137	0	0	0	0	0	0	113	112	0	225	153	0	18	0	171	533
08:15 AM	15	83	0	0	98	0	0	0	0	0	0	70	113	0	183	132	0	26	0	158	439
08:30 AM	22	94	0	0	116	0	0	0	0	0	0	102	106	0	208	109	0	28	0	137	461
08:45 AM	12	101	0	0	113	0	0	0	0	0	0	81	133	0	214	167	0	11	0	178	505
Total Volume	66	398	0	0	464	0	0	0	0	0	0	366	464	0	830	561	0	83	0	644	1938
% App. Total	14.2	85.8	0	0		0	0	0	0		0	44.1	55.9	0		87.1	0	12.9	0		
PHF	.750	.829	.000	.000	.847	.000	.000	.000	.000	.000	.000	.810	.872	.000	.922	.840	.000	.741	.000	.904	.909

# Traffic Data Service

Campbell, CA  
 (408) 377-2988  
 tdsbay@cs.com

File Name : 12AM FINAL  
 Site Code : 00000012  
 Start Date : 11/10/2010  
 Page No : 2

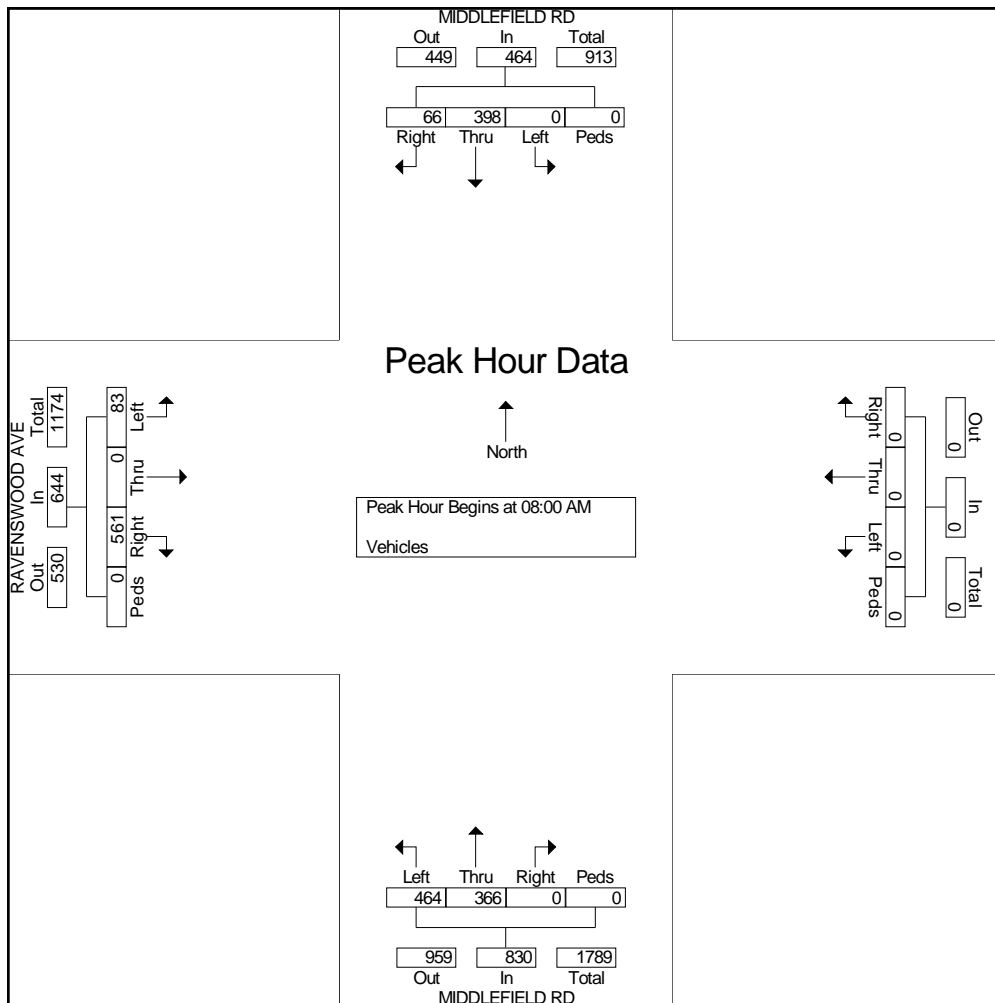

# Traffic Data Service

Campbell, CA  
(408) 377-2988  
tdsbay@cs.com

File Name : 12PM FINAL  
Site Code : 00000012  
Start Date : 11/10/2010  
Page No : 1

### Groups Printed- Vehicles

Start Time	MIDDLEFIELD RD Southbound					Westbound					MIDDLEFIELD RD Northbound					RAVENSWOOD AVE Eastbound					Int. Total
	Right	Thru	Left	Peds	App. Total	Right	Thru	Left	Peds	App. Total	Right	Thru	Left	Peds	App. Total	Right	Thru	Left	Peds	App. Total	
04:00 PM	15	85	0	0	100	0	0	0	0	0	0	133	118	0	251	145	0	43	0	188	539
04:15 PM	19	87	0	0	106	0	0	0	0	0	0	140	109	0	249	131	0	40	0	171	526
04:30 PM	28	81	0	0	109	0	0	0	0	0	0	131	108	0	239	130	0	79	0	209	557
04:45 PM	16	90	0	0	106	0	0	0	0	0	0	137	103	0	240	140	0	62	0	202	548
<b>Total</b>	<b>78</b>	<b>343</b>	<b>0</b>	<b>0</b>	<b>421</b>	<b>0</b>	<b>0</b>	<b>0</b>	<b>0</b>	<b>0</b>	<b>0</b>	<b>541</b>	<b>438</b>	<b>0</b>	<b>979</b>	<b>546</b>	<b>0</b>	<b>224</b>	<b>0</b>	<b>770</b>	<b>2170</b>
05:00 PM	19	100	0	0	119	0	0	0	0	0	0	147	116	0	263	165	0	57	0	222	604
05:15 PM	20	100	0	0	120	0	0	0	0	0	0	137	138	0	275	158	0	65	0	223	618
05:30 PM	34	115	0	0	149	0	0	0	0	0	0	146	117	0	263	185	0	76	0	261	673
05:45 PM	19	42	0	0	61	0	0	0	0	0	0	136	116	0	252	197	0	59	0	256	569
<b>Total</b>	<b>92</b>	<b>357</b>	<b>0</b>	<b>0</b>	<b>449</b>	<b>0</b>	<b>0</b>	<b>0</b>	<b>0</b>	<b>0</b>	<b>0</b>	<b>566</b>	<b>487</b>	<b>0</b>	<b>1053</b>	<b>705</b>	<b>0</b>	<b>257</b>	<b>0</b>	<b>962</b>	<b>2464</b>
<b>Grand Total</b>	<b>170</b>	<b>700</b>	<b>0</b>	<b>0</b>	<b>870</b>	<b>0</b>	<b>0</b>	<b>0</b>	<b>0</b>	<b>0</b>	<b>0</b>	<b>1107</b>	<b>925</b>	<b>0</b>	<b>2032</b>	<b>1251</b>	<b>0</b>	<b>481</b>	<b>0</b>	<b>1732</b>	<b>4634</b>
Approch %	19.5	80.5	0	0		0	0	0	0			54.5	45.5	0		72.2	0	27.8	0		
Total %	3.7	15.1	0	0	18.8	0	0	0	0	0		23.9	20	0	43.8	27	0	10.4	0	37.4	

Start Time	MIDDLEFIELD RD Southbound					Westbound					MIDDLEFIELD RD Northbound					RAVENSWOOD AVE Eastbound					Int. Total
	Right	Thru	Left	Peds	App. Total	Right	Thru	Left	Peds	App. Total	Right	Thru	Left	Peds	App. Total	Right	Thru	Left	Peds	App. Total	
Peak Hour Analysis From 04:00 PM to 05:45 PM - Peak 1 of 1																					
Peak Hour for Entire Intersection Begins at 05:00 PM																					
05:00 PM	19	100	0	0	119	0	0	0	0	0	0	147	116	0	263	165	0	57	0	222	604
05:15 PM	20	100	0	0	120	0	0	0	0	0	0	137	138	0	275	158	0	65	0	223	618
05:30 PM	34	115	0	0	149	0	0	0	0	0	0	146	117	0	263	185	0	76	0	261	673
05:45 PM	19	42	0	0	61	0	0	0	0	0	0	136	116	0	252	197	0	59	0	256	569
<b>Total Volume</b>	<b>92</b>	<b>357</b>	<b>0</b>	<b>0</b>	<b>449</b>	<b>0</b>	<b>0</b>	<b>0</b>	<b>0</b>	<b>0</b>	<b>0</b>	<b>566</b>	<b>487</b>	<b>0</b>	<b>1053</b>	<b>705</b>	<b>0</b>	<b>257</b>	<b>0</b>	<b>962</b>	<b>2464</b>
<b>% App. Total</b>	<b>20.5</b>	<b>79.5</b>	<b>0</b>	<b>0</b>		<b>0</b>	<b>0</b>	<b>0</b>	<b>0</b>			<b>53.8</b>	<b>46.2</b>	<b>0</b>		<b>73.3</b>	<b>0</b>	<b>26.7</b>	<b>0</b>		
<b>PHF</b>	<b>.676</b>	<b>.776</b>	<b>.000</b>	<b>.000</b>	<b>.753</b>	<b>.000</b>	<b>.000</b>	<b>.000</b>	<b>.000</b>	<b>.000</b>	<b>.000</b>	<b>.963</b>	<b>.882</b>	<b>.000</b>	<b>.957</b>	<b>.895</b>	<b>.000</b>	<b>.845</b>	<b>.000</b>	<b>.921</b>	<b>.915</b>

# Traffic Data Service

Campbell, CA  
 (408) 377-2988  
 tdsbay@cs.com

File Name : 12PM FINAL  
 Site Code : 00000012  
 Start Date : 11/10/2010  
 Page No : 2

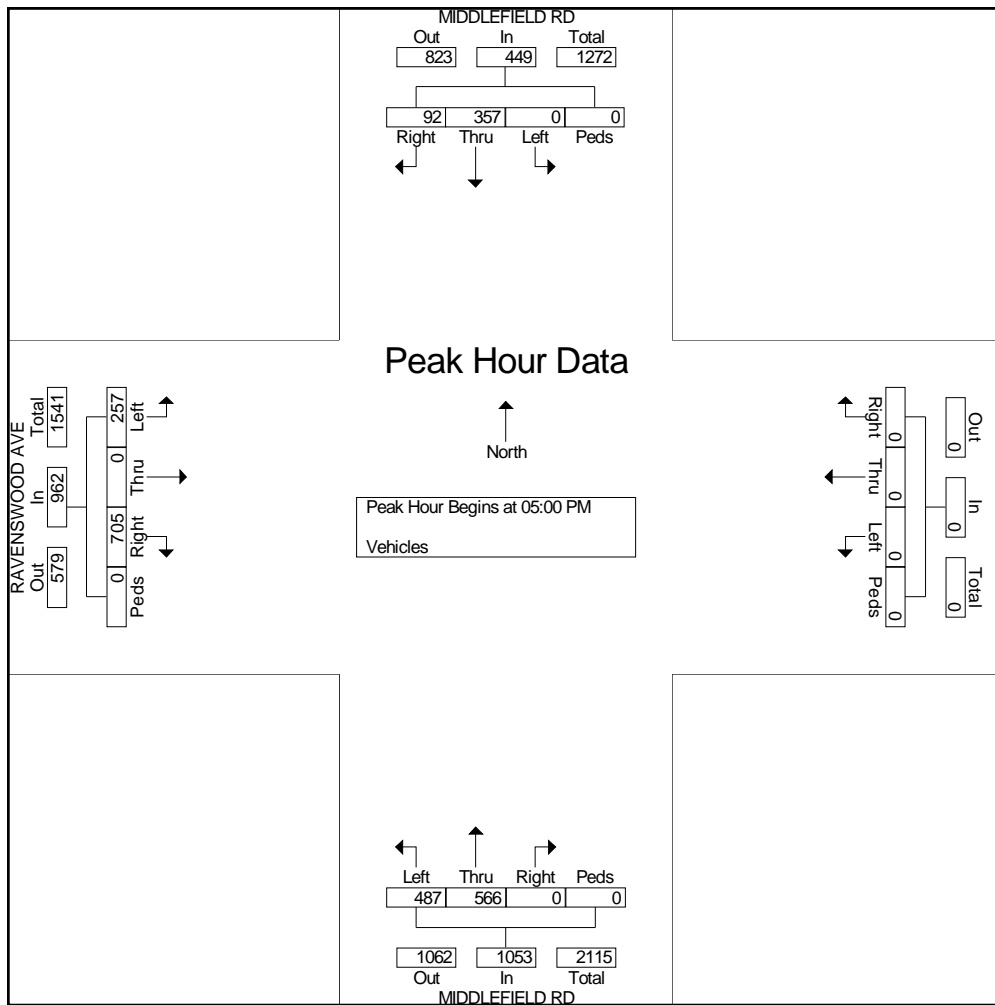

# Traffic Data Service

Campbell, CA  
(408) 377-2988  
tdsbay@cs.com

File Name : 11AM FINAL  
Site Code : 00000011  
Start Date : 11/10/2010  
Page No : 1

### Groups Printed- Vehicles

Start Time	MIDDLEFIELD RD Southbound					RINGWOOD AVE Westbound					MIDDLEFIELD RD Northbound					D ST Eastbound					Int. Total
	Right	Thru	Left	Peds	App. Total	Right	Thru	Left	Peds	App. Total	Right	Thru	Left	Peds	App. Total	Right	Thru	Left	Peds	App. Total	
07:00 AM	19	78	13	0	110	29	9	3	0	41	2	111	12	0	125	1	0	0	0	1	277
07:15 AM	13	88	5	0	106	55	8	10	0	73	8	135	6	0	149	1	1	1	0	3	331
07:30 AM	7	137	13	0	157	48	11	10	0	69	9	203	6	0	218	0	0	1	0	1	445
07:45 AM	12	155	35	0	202	73	10	25	0	108	10	193	9	0	212	3	0	1	0	4	526
<b>Total</b>	<b>51</b>	<b>458</b>	<b>66</b>	<b>0</b>	<b>575</b>	<b>205</b>	<b>38</b>	<b>48</b>	<b>0</b>	<b>291</b>	<b>29</b>	<b>642</b>	<b>33</b>	<b>0</b>	<b>704</b>	<b>5</b>	<b>1</b>	<b>3</b>	<b>0</b>	<b>9</b>	<b>1579</b>
08:00 AM	22	195	55	0	272	48	13	28	0	89	15	181	14	0	210	1	2	0	0	3	574
08:15 AM	17	186	30	0	233	63	13	32	0	108	12	131	19	0	162	0	1	1	0	2	505
08:30 AM	18	154	36	0	208	55	10	23	0	88	12	166	16	0	194	2	0	2	0	4	494
08:45 AM	11	174	71	0	256	75	17	40	0	132	10	145	8	0	163	0	0	0	0	0	551
<b>Total</b>	<b>68</b>	<b>709</b>	<b>192</b>	<b>0</b>	<b>969</b>	<b>241</b>	<b>53</b>	<b>123</b>	<b>0</b>	<b>417</b>	<b>49</b>	<b>623</b>	<b>57</b>	<b>0</b>	<b>729</b>	<b>3</b>	<b>3</b>	<b>3</b>	<b>0</b>	<b>9</b>	<b>2124</b>
<b>Grand Total</b>	<b>119</b>	<b>1167</b>	<b>258</b>	<b>0</b>	<b>1544</b>	<b>446</b>	<b>91</b>	<b>171</b>	<b>0</b>	<b>708</b>	<b>78</b>	<b>1265</b>	<b>90</b>	<b>0</b>	<b>1433</b>	<b>8</b>	<b>4</b>	<b>6</b>	<b>0</b>	<b>18</b>	<b>3703</b>
<b>Apprch %</b>	<b>7.7</b>	<b>75.6</b>	<b>16.7</b>	<b>0</b>		<b>63</b>	<b>12.9</b>	<b>24.2</b>	<b>0</b>		<b>5.4</b>	<b>88.3</b>	<b>6.3</b>	<b>0</b>		<b>44.4</b>	<b>22.2</b>	<b>33.3</b>	<b>0</b>		
<b>Total %</b>	<b>3.2</b>	<b>31.5</b>	<b>7</b>	<b>0</b>	<b>41.7</b>	<b>12</b>	<b>2.5</b>	<b>4.6</b>	<b>0</b>	<b>19.1</b>	<b>2.1</b>	<b>34.2</b>	<b>2.4</b>	<b>0</b>	<b>38.7</b>	<b>0.2</b>	<b>0.1</b>	<b>0.2</b>	<b>0</b>	<b>0.5</b>	

Start Time	MIDDLEFIELD RD Southbound					RINGWOOD AVE Westbound					MIDDLEFIELD RD Northbound					D ST Eastbound					Int. Total
	Right	Thru	Left	Peds	App. Total	Right	Thru	Left	Peds	App. Total	Right	Thru	Left	Peds	App. Total	Right	Thru	Left	Peds	App. Total	
Peak Hour Analysis From 07:00 AM to 08:45 AM - Peak 1 of 1																					
Peak Hour for Entire Intersection Begins at 08:00 AM																					
08:00 AM	22	195	55	0	272	48	13	28	0	89	15	181	14	0	210	1	2	0	0	3	574
08:15 AM	17	186	30	0	233	63	13	32	0	108	12	131	19	0	162	0	1	1	0	2	505
08:30 AM	18	154	36	0	208	55	10	23	0	88	12	166	16	0	194	2	0	2	0	4	494
08:45 AM	11	174	71	0	256	75	17	40	0	132	10	145	8	0	163	0	0	0	0	0	551
<b>Total Volume</b>	<b>68</b>	<b>709</b>	<b>192</b>	<b>0</b>	<b>969</b>	<b>241</b>	<b>53</b>	<b>123</b>	<b>0</b>	<b>417</b>	<b>49</b>	<b>623</b>	<b>57</b>	<b>0</b>	<b>729</b>	<b>3</b>	<b>3</b>	<b>3</b>	<b>0</b>	<b>9</b>	<b>2124</b>
<b>% App. Total</b>	<b>7</b>	<b>73.2</b>	<b>19.8</b>	<b>0</b>		<b>57.8</b>	<b>12.7</b>	<b>29.5</b>	<b>0</b>		<b>6.7</b>	<b>85.5</b>	<b>7.8</b>	<b>0</b>		<b>33.3</b>	<b>33.3</b>	<b>33.3</b>	<b>0</b>		
<b>PHF</b>	<b>.773</b>	<b>.909</b>	<b>.676</b>	<b>.000</b>	<b>.891</b>	<b>.803</b>	<b>.779</b>	<b>.769</b>	<b>.000</b>	<b>.790</b>	<b>.817</b>	<b>.860</b>	<b>.750</b>	<b>.000</b>	<b>.868</b>	<b>.375</b>	<b>.375</b>	<b>.375</b>	<b>.000</b>	<b>.563</b>	<b>.925</b>

# Traffic Data Service

Campbell, CA  
 (408) 377-2988  
 tdsbay@cs.com

File Name : 11AM FINAL  
 Site Code : 00000011  
 Start Date : 11/10/2010  
 Page No : 2

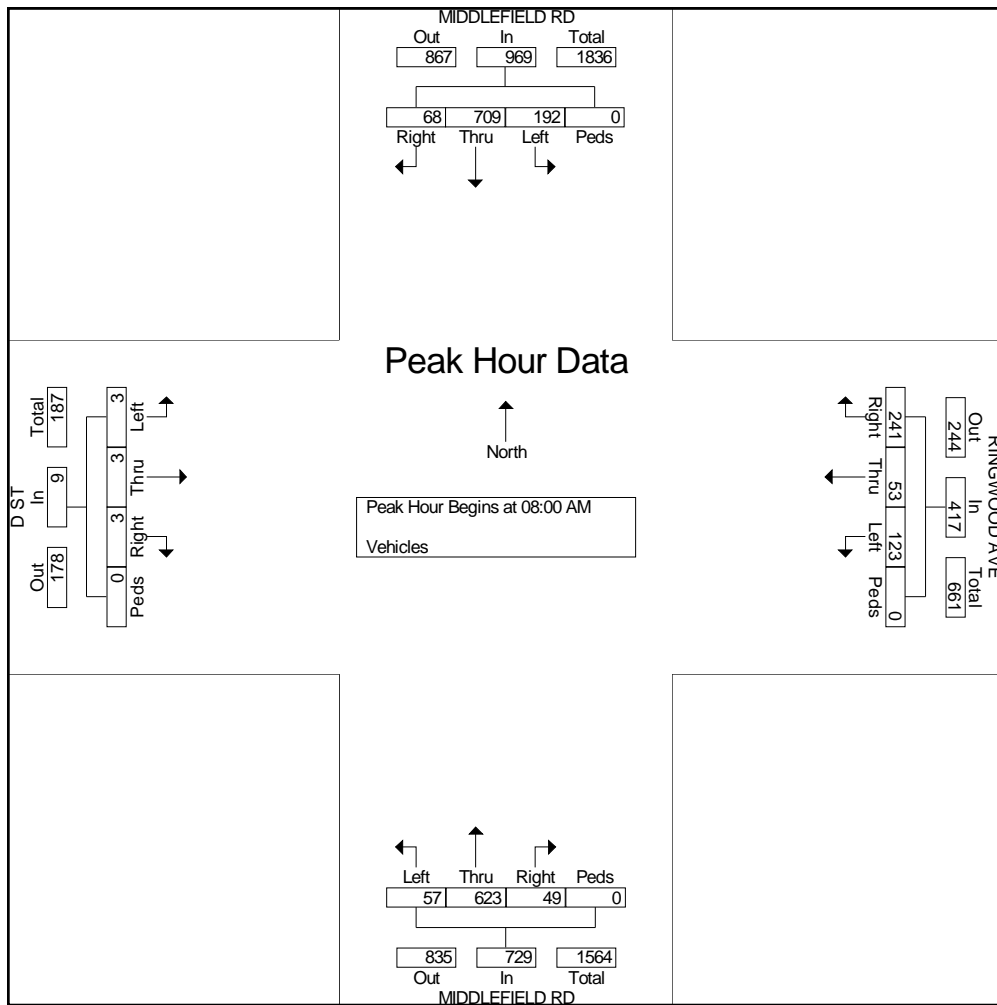



# Traffic Data Service

Campbell, CA  
(408) 377-2988  
tdsbay@cs.com

File Name : 11PM FINAL  
Site Code : 00000011  
Start Date : 11/10/2010  
Page No : 1

### Groups Printed- Vehicles

Start Time	MIDDLEFIELD RD Southbound					RINGWOOD Westbound					MIDDLEFIELD RD Northbound					D ST Eastbound					Int. Total
	Right	Thru	Left	Peds	App. Total	Right	Thru	Left	Peds	App. Total	Right	Thru	Left	Peds	App. Total	Right	Thru	Left	Peds	App. Total	
04:00 PM	6	149	68	0	223	38	0	11	0	49	24	201	1	0	226	6	23	11	0	40	538
04:15 PM	2	166	57	0	225	49	0	12	0	61	17	183	2	0	202	8	12	13	0	33	521
04:30 PM	2	150	54	0	206	32	0	7	0	39	12	190	1	0	203	11	10	22	0	43	491
04:45 PM	2	162	70	0	234	31	0	9	0	40	26	185	4	0	215	8	15	20	0	43	532
<b>Total</b>	<b>12</b>	<b>627</b>	<b>249</b>	<b>0</b>	<b>888</b>	<b>150</b>	<b>0</b>	<b>39</b>	<b>0</b>	<b>189</b>	<b>79</b>	<b>759</b>	<b>8</b>	<b>0</b>	<b>846</b>	<b>33</b>	<b>60</b>	<b>66</b>	<b>0</b>	<b>159</b>	<b>2082</b>
05:00 PM	6	172	68	0	246	51	3	15	0	69	23	203	5	0	231	12	27	21	0	60	606
05:15 PM	9	154	96	0	259	67	1	13	0	81	25	189	9	1	224	18	24	30	0	72	636
05:30 PM	7	174	84	0	265	71	3	17	0	91	30	192	18	0	240	20	12	12	0	44	640
05:45 PM	14	128	108	0	250	77	1	28	0	106	49	177	17	0	243	12	13	12	0	37	636
<b>Total</b>	<b>36</b>	<b>628</b>	<b>356</b>	<b>0</b>	<b>1020</b>	<b>266</b>	<b>8</b>	<b>73</b>	<b>0</b>	<b>347</b>	<b>127</b>	<b>761</b>	<b>49</b>	<b>1</b>	<b>938</b>	<b>62</b>	<b>76</b>	<b>75</b>	<b>0</b>	<b>213</b>	<b>2518</b>
<b>Grand Total</b>	<b>48</b>	<b>1255</b>	<b>605</b>	<b>0</b>	<b>1908</b>	<b>416</b>	<b>8</b>	<b>112</b>	<b>0</b>	<b>536</b>	<b>206</b>	<b>1520</b>	<b>57</b>	<b>1</b>	<b>1784</b>	<b>95</b>	<b>136</b>	<b>141</b>	<b>0</b>	<b>372</b>	<b>4600</b>
<b>Apprch %</b>	<b>2.5</b>	<b>65.8</b>	<b>31.7</b>	<b>0</b>		<b>77.6</b>	<b>1.5</b>	<b>20.9</b>	<b>0</b>		<b>11.5</b>	<b>85.2</b>	<b>3.2</b>	<b>0.1</b>		<b>25.5</b>	<b>36.6</b>	<b>37.9</b>	<b>0</b>		
<b>Total %</b>	<b>1</b>	<b>27.3</b>	<b>13.2</b>	<b>0</b>	<b>41.5</b>	<b>9</b>	<b>0.2</b>	<b>2.4</b>	<b>0</b>	<b>11.7</b>	<b>4.5</b>	<b>33</b>	<b>1.2</b>	<b>0</b>	<b>38.8</b>	<b>2.1</b>	<b>3</b>	<b>3.1</b>	<b>0</b>	<b>8.1</b>	

Start Time	MIDDLEFIELD RD Southbound					RINGWOOD Westbound					MIDDLEFIELD RD Northbound					D ST Eastbound					Int. Total
	Right	Thru	Left	Peds	App. Total	Right	Thru	Left	Peds	App. Total	Right	Thru	Left	Peds	App. Total	Right	Thru	Left	Peds	App. Total	
Peak Hour Analysis From 04:00 PM to 05:45 PM - Peak 1 of 1																					
Peak Hour for Entire Intersection Begins at 05:00 PM																					
05:00 PM	6	172	68	0	246	51	3	15	0	69	23	203	5	0	231	12	27	21	0	60	606
05:15 PM	9	154	96	0	259	67	1	13	0	81	25	189	9	1	224	18	24	30	0	72	636
05:30 PM	7	174	84	0	265	71	3	17	0	91	30	192	18	0	240	20	12	12	0	44	640
05:45 PM	14	128	108	0	250	77	1	28	0	106	49	177	17	0	243	12	13	12	0	37	636
<b>Total Volume</b>	<b>36</b>	<b>628</b>	<b>356</b>	<b>0</b>	<b>1020</b>	<b>266</b>	<b>8</b>	<b>73</b>	<b>0</b>	<b>347</b>	<b>127</b>	<b>761</b>	<b>49</b>	<b>1</b>	<b>938</b>	<b>62</b>	<b>76</b>	<b>75</b>	<b>0</b>	<b>213</b>	<b>2518</b>
<b>% App. Total</b>	<b>3.5</b>	<b>61.6</b>	<b>34.9</b>	<b>0</b>		<b>76.7</b>	<b>2.3</b>	<b>21</b>	<b>0</b>		<b>13.5</b>	<b>81.1</b>	<b>5.2</b>	<b>0.1</b>		<b>29.1</b>	<b>35.7</b>	<b>35.2</b>	<b>0</b>		
<b>PHF</b>	<b>.643</b>	<b>.902</b>	<b>.824</b>	<b>.000</b>	<b>.962</b>	<b>.864</b>	<b>.667</b>	<b>.652</b>	<b>.000</b>	<b>.818</b>	<b>.648</b>	<b>.937</b>	<b>.681</b>	<b>.250</b>	<b>.965</b>	<b>.775</b>	<b>.704</b>	<b>.625</b>	<b>.000</b>	<b>.740</b>	<b>.984</b>

# Traffic Data Service

Campbell, CA  
 (408) 377-2988  
 tdsbay@cs.com

File Name : 11PM FINAL  
 Site Code : 00000011  
 Start Date : 11/10/2010  
 Page No : 2

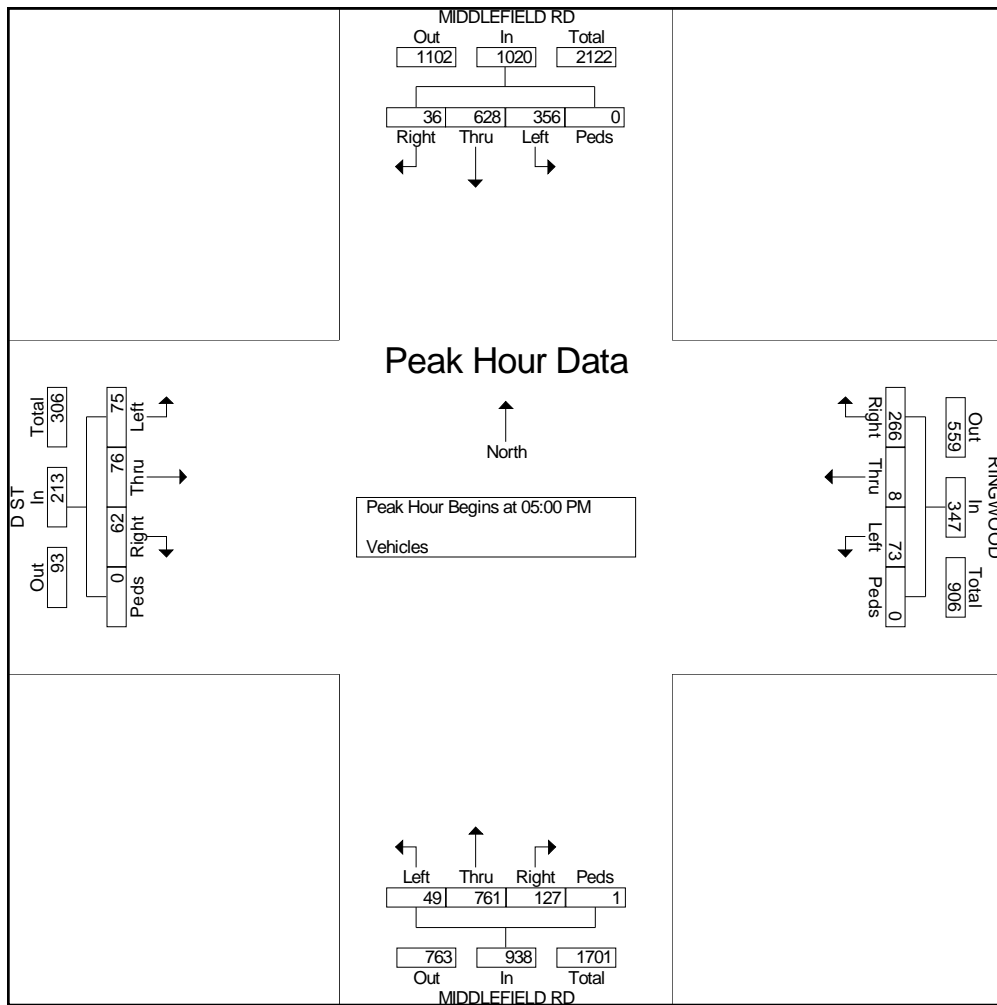

# Traffic Data Service

Campbell, CA  
(408) 377-2988  
tdsbay@cs.com

File Name : 9AM FINAL  
Site Code : 00000009  
Start Date : 11/10/2010  
Page No : 1

### Groups Printed- Vehicles

Start Time	MIDDLEFIELD RD Southbound					LYTTON AVE Westbound					MIDDLEFIELD RD Northbound					LYTTON AVE Eastbound					Int. Total
	Right	Thru	Left	Peds	App. Total	Right	Thru	Left	Peds	App. Total	Right	Thru	Left	Peds	App. Total	Right	Thru	Left	Peds	App. Total	
07:00 AM	63	46	0	0	109	0	5	0	0	5	0	38	15	0	53	15	1	19	0	35	202
07:15 AM	90	58	0	0	148	2	16	0	0	18	1	49	23	0	73	7	1	33	0	41	280
07:30 AM	70	84	1	0	155	3	23	1	0	27	0	46	29	0	75	7	14	39	0	60	317
07:45 AM	107	103	2	0	212	1	31	0	0	32	2	60	22	0	84	5	4	36	0	45	373
<b>Total</b>	<b>330</b>	<b>291</b>	<b>3</b>	<b>0</b>	<b>624</b>	<b>6</b>	<b>75</b>	<b>1</b>	<b>0</b>	<b>82</b>	<b>3</b>	<b>193</b>	<b>89</b>	<b>0</b>	<b>285</b>	<b>34</b>	<b>20</b>	<b>127</b>	<b>0</b>	<b>181</b>	<b>1172</b>
08:00 AM	74	109	1	0	184	2	29	1	0	32	3	67	30	0	100	6	5	28	0	39	355
08:15 AM	99	123	2	0	224	0	26	1	0	27	1	88	27	0	116	13	13	25	0	51	418
08:30 AM	85	129	3	0	217	1	20	3	0	24	3	74	30	0	107	10	11	35	0	56	404
08:45 AM	97	129	1	0	227	2	22	1	0	25	1	85	28	0	114	16	5	26	0	47	413
<b>Total</b>	<b>355</b>	<b>490</b>	<b>7</b>	<b>0</b>	<b>852</b>	<b>5</b>	<b>97</b>	<b>6</b>	<b>0</b>	<b>108</b>	<b>8</b>	<b>314</b>	<b>115</b>	<b>0</b>	<b>437</b>	<b>45</b>	<b>34</b>	<b>114</b>	<b>0</b>	<b>193</b>	<b>1590</b>
<b>Grand Total</b>	<b>685</b>	<b>781</b>	<b>10</b>	<b>0</b>	<b>1476</b>	<b>11</b>	<b>172</b>	<b>7</b>	<b>0</b>	<b>190</b>	<b>11</b>	<b>507</b>	<b>204</b>	<b>0</b>	<b>722</b>	<b>79</b>	<b>54</b>	<b>241</b>	<b>0</b>	<b>374</b>	<b>2762</b>
Apprch %	46.4	52.9	0.7	0		5.8	90.5	3.7	0		1.5	70.2	28.3	0		21.1	14.4	64.4	0		
Total %	24.8	28.3	0.4	0	53.4	0.4	6.2	0.3	0	6.9	0.4	18.4	7.4	0	26.1	2.9	2	8.7	0	13.5	

Start Time	MIDDLEFIELD RD Southbound					LYTTON AVE Westbound					MIDDLEFIELD RD Northbound					LYTTON AVE Eastbound					Int. Total
	Right	Thru	Left	Peds	App. Total	Right	Thru	Left	Peds	App. Total	Right	Thru	Left	Peds	App. Total	Right	Thru	Left	Peds	App. Total	
Peak Hour Analysis From 07:00 AM to 08:45 AM - Peak 1 of 1																					
Peak Hour for Entire Intersection Begins at 08:00 AM																					
08:00 AM	74	109	1	0	184	2	29	1	0	32	3	67	30	0	100	6	5	28	0	39	355
08:15 AM	99	123	2	0	224	0	26	1	0	27	1	88	27	0	116	13	13	25	0	51	418
08:30 AM	85	129	3	0	217	1	20	3	0	24	3	74	30	0	107	10	11	35	0	56	404
08:45 AM	97	129	1	0	227	2	22	1	0	25	1	85	28	0	114	16	5	26	0	47	413
Total Volume	355	490	7	0	852	5	97	6	0	108	8	314	115	0	437	45	34	114	0	193	1590
% App. Total	41.7	57.5	0.8	0		4.6	89.8	5.6	0		1.8	71.9	26.3	0		23.3	17.6	59.1	0		
PHF	.896	.950	.583	.000	.938	.625	.836	.500	.000	.844	.667	.892	.958	.000	.942	.703	.654	.814	.000	.862	.951

# Traffic Data Service

Campbell, CA  
 (408) 377-2988  
 tdsbay@cs.com

File Name : 9AM FINAL  
 Site Code : 00000009  
 Start Date : 11/10/2010  
 Page No : 2

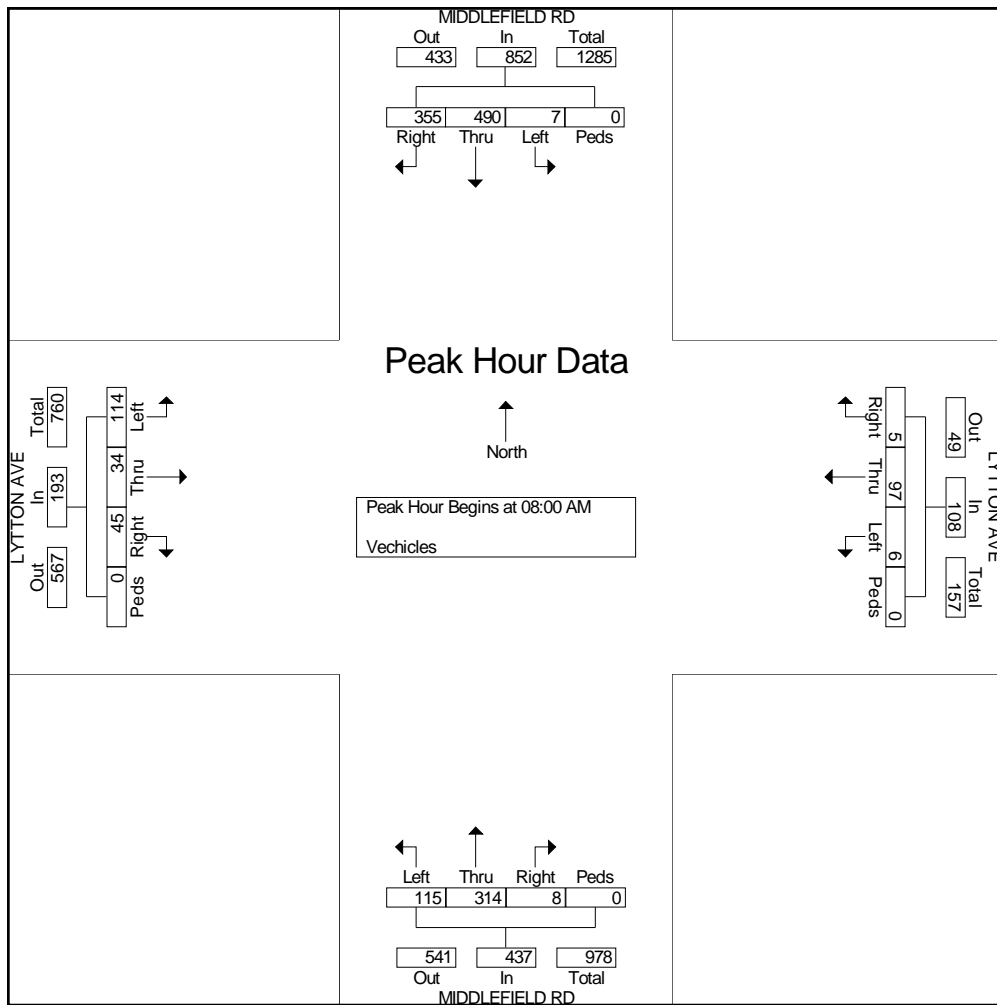

# Traffic Data Service

Campbell, CA  
(408) 377-2988  
tdsbay@cs.com

File Name : 9PM FINAL  
Site Code : 00000009  
Start Date : 11/10/2010  
Page No : 1

### Groups Printed- Vehicles

Start Time	MIDDLEFIELD RD Southbound					LYTTON AVE Westbound					MIDDLEFIELD RD Northbound					LYTTON AVE Eastbound					Int. Total
	Right	Thru	Left	Peds	App. Total	Right	Thru	Left	Peds	App. Total	Right	Thru	Left	Peds	App. Total	Right	Thru	Left	Peds	App. Total	
04:00 PM	53	77	6	0	136	1	11	0	0	12	3	98	15	0	116	33	37	84	0	154	418
04:15 PM	45	92	7	0	144	1	12	0	0	13	1	101	30	0	132	15	20	66	0	101	390
04:30 PM	28	93	5	0	126	3	12	1	0	16	4	109	24	0	137	21	45	107	0	173	452
04:45 PM	45	121	3	0	169	3	11	0	0	14	7	118	16	0	141	13	34	85	0	132	456
<b>Total</b>	<b>171</b>	<b>383</b>	<b>21</b>	<b>0</b>	<b>575</b>	<b>8</b>	<b>46</b>	<b>1</b>	<b>0</b>	<b>55</b>	<b>15</b>	<b>426</b>	<b>85</b>	<b>0</b>	<b>526</b>	<b>82</b>	<b>136</b>	<b>342</b>	<b>0</b>	<b>560</b>	<b>1716</b>
05:00 PM	38	115	2	0	155	3	6	2	0	11	6	124	20	0	150	23	33	116	0	172	488
05:15 PM	36	120	9	0	165	3	15	3	0	21	5	104	21	0	130	21	43	101	0	165	481
05:30 PM	48	163	8	0	219	4	15	2	0	21	5	126	27	0	158	11	29	104	0	144	542
05:45 PM	41	110	5	0	156	2	19	0	0	21	11	103	21	0	135	23	30	98	0	151	463
<b>Total</b>	<b>163</b>	<b>508</b>	<b>24</b>	<b>0</b>	<b>695</b>	<b>12</b>	<b>55</b>	<b>7</b>	<b>0</b>	<b>74</b>	<b>27</b>	<b>457</b>	<b>89</b>	<b>0</b>	<b>573</b>	<b>78</b>	<b>135</b>	<b>419</b>	<b>0</b>	<b>632</b>	<b>1974</b>
Grand Total	334	891	45	0	1270	20	101	8	0	129	42	883	174	0	1099	160	271	761	0	1192	3690
Apprch %	26.3	70.2	3.5	0		15.5	78.3	6.2	0		3.8	80.3	15.8	0		13.4	22.7	63.8	0		
Total %	9.1	24.1	1.2	0	34.4	0.5	2.7	0.2	0	3.5	1.1	23.9	4.7	0	29.8	4.3	7.3	20.6	0	32.3	

Start Time	MIDDLEFIELD RD Southbound					LYTTON AVE Westbound					MIDDLEFIELD RD Northbound					LYTTON AVE Eastbound					Int. Total
	Right	Thru	Left	Peds	App. Total	Right	Thru	Left	Peds	App. Total	Right	Thru	Left	Peds	App. Total	Right	Thru	Left	Peds	App. Total	
Peak Hour Analysis From 04:00 PM to 05:45 PM - Peak 1 of 1																					
Peak Hour for Entire Intersection Begins at 05:00 PM																					
05:00 PM	38	115	2	0	155	3	6	2	0	11	6	124	20	0	150	23	33	116	0	172	488
05:15 PM	36	120	9	0	165	3	15	3	0	21	5	104	21	0	130	21	43	101	0	165	481
05:30 PM	48	163	8	0	219	4	15	2	0	21	5	126	27	0	158	11	29	104	0	144	542
05:45 PM	41	110	5	0	156	2	19	0	0	21	11	103	21	0	135	23	30	98	0	151	463
Total Volume	163	508	24	0	695	12	55	7	0	74	27	457	89	0	573	78	135	419	0	632	1974
% App. Total	23.5	73.1	3.5	0		16.2	74.3	9.5	0		4.7	79.8	15.5	0		12.3	21.4	66.3	0		
PHF	.849	.779	.667	.000	.793	.750	.724	.583	.000	.881	.614	.907	.824	.000	.907	.848	.785	.903	.000	.919	.911

# Traffic Data Service

Campbell, CA  
 (408) 377-2988  
 tdsbay@cs.com

File Name : 9PM FINAL  
 Site Code : 00000009  
 Start Date : 11/10/2010  
 Page No : 2

